

DIVISION OF STATE PARKS

State of Hawaii
DEPARTMENT OF LAND AND NATURAL RESOURCES
ENGINEERING DIVISION
Honolulu, Hawaii

BOARD OF LAND AND NATURAL RESOURCES

Suzanne D. Case
Chairperson

CONTRACT SPECIFICATIONS AND PLANS

JOB NO. F27C793B
HEEIA STATE PARK
REPAIRS TO SERVICE ROAD
KANEOHE, OAHU, HAWAII

MAY 2016

State of Hawaii
DEPARTMENT OF LAND AND NATURAL RESOURCES
ENGINEERING DIVISION
Honolulu, Hawaii

CONTRACT SPECIFICATIONS AND PLANS

JOB NO. F27C793B
HEEIA STATE PARK
REPAIRS TO SERVICE ROAD
KANEHOE, OAHU, HAWAII

Approved:



CURT COTTRELL
Administrator
Division of State Parks

Approved:



CARTY S. CHANG, P.E.
Chief Engineer
Engineering Division

MAY 2016

NOTICE TO BIDDERS	iii
INFORMATION AND INSTRUCTIONS TO BIDDERS	I-1
PROPOSAL	P-1
SPECIAL PROVISIONS	SP-1
DETAILED SPECIFICATIONS	S-1

PLANS (Bound Separately)

DEPARTMENT OF LAND AND NATURAL RESOURCES INTERIM GENERAL
CONDITIONS, DATED OCTOBER 1994 (Bound Separately)

NOTICE TO BIDDERS
(Chapter 103D, HRS)

COMPETITIVE BIDS for Job No. F27C793B Heeia State Park, Oahu, Repairs to Service Road, Kaneohe, Oahu, Hawaii shall be submitted to the Department of Land and Natural Resources, Engineering Division on the specified date and time through the Hawaii State e-Procurement (HIePRO). HIePRO is accessible through the State Procurement Office website at www.spo.hawaii.gov.

The Department of Land and Natural Resources Interim General Condition, dated October 1994, as amended, and the General Conditions –AG008, latest revision shall be made part of the specifications.

The project is located at Heeia State Park, Kaneohe, Oahu, Hawaii.

The work shall generally consist of resurfacing existing service road, building a gravel turning area, replacing and installing posts with chain barrier.

Due to the nature of work contemplated, bidders must possess a valid State Contractor's license, classification "A".

The estimated cost of construction is \$100,000.

The award of the contract, if it be awarded, will be subject to the availability of funds.

This project is subject to preference to Hawaii Products established by Section 103D, Hawaii Revised Statutes. The Hawaii Product List may be examined at the State Procurement Office website.

Since the estimated value of the cost of construction is less than \$250,000, the apprenticeship agreement preference pursuant to Hawaii Revised Statutes §103-55.6 (ACT 17, SLH 2009) shall not apply.

Should there be any questions, please refer to the HIePRO solicitation.

INFORMATION AND INSTRUCTIONS TO BIDDERS

CONTENTS

		<u>Page</u>
A	Project Location and Scope of Work	I-2
B	Proposals	I-2
C	General Conditions	I-2
D	Proposal Form	I-2
E	Omissions or Erasures	I-2
F	Notice of Intent to Bid and Questionnaire	I-2
G	Bid Security	I-2
H	Contractor's License Required	I-2
I	Irregular Bids	I-3
J	Withdrawal of Bids	I-3
K	Successful Bidder to File Performance and Payment Bonds	I-3
L	Number of Executed Original Counterparts of Contract Documents	I-3
M	Change Orders	I-3
N	Wages and Hours	I-3
O	Permits	I-3
P	Property Damage	I-4
Q	Time	I-4
R	Bidder's Responsibility to Provide Proper Superintendence	I-4
S	Liquidated Damages	I-4
T	Hiring of Hawaii Residents	I-4
U	Water and Electricity	I-5
V	Public Convenience and Safety	I-5
W	Work to be Done Without Direct Payment.....	I-5
X	As-Built Drawings	I-5
Y	Asbestos Containing Materials	I-5
Z	Worker Safety	I-5
AA	Toilet Facilities	I-6
BB	Signs	I-6
CC	Field Office for Department	I-6
DD	Quantities	I-6
EE	Other Health Measures	I-6
FF	Hawaii Business Requirement	I-6
GG	Compliance With §3-122-112 HAR	I-7

INFORMATION AND INSTRUCTIONS TO BIDDERS

- A. PROJECT LOCATION AND SCOPE OF WORK: The project location and scope of work shall be as generally described in the Notice to Bidders.
- B. PROPOSALS: Bidders shall submit their bid, including the completed proposal form, bid bond, and any other documents required by the solicitation as part of their bid through the State of Hawaii e-Procurement System (HIePRO). See Item D, PROPOSAL FORM.
- C. GENERAL CONDITIONS: The Department of Land and Natural Resources Interim General Conditions dated October 1994, as amended, shall be made a part of these contract specifications and are referred to hereafter as the General Conditions.
- D. PROPOSAL FORM: **The Bidders shall fill out and upload the electronic copy of the proposal form to the HIePRO website when submitting the bid. Bid Proposals shall not be mailed, faxed or delivered to the State, unless requested to do so after the designated closing date. The successful Bidder shall fill out and print a hard copy of the proposal form, sign and submit the form with the contract award package.**
- E. OMISSIONS OR ERASURES: Any proposal which contains any omission or erasure or alteration not properly initialed, or conditional bid, or other irregularity may be rejected by the Board of Land and Natural Resources (Board).
- F. NOTICE OF INTENT TO BID AND QUESTIONNAIRE:
A Notice of Intent to Bid is not required for this project. In compliance with HRS Section 103D-310, the lowest responsive and responsible bidder may be required to complete a questionnaire. When requested by the State, the completed questionnaire shall be submitted to the Chief Engineer for evaluation. Failure to furnish the requested information within the time allowed may be grounds for a determination of non-responsibility, in accordance with HRS Section 103D-310 and HAR Section 3-122-108.
- G. BID SECURITY: A bid security will be furnished by each bidder as provided in sub-section 2.7 of the General Conditions. The successful bidder's bid security will be retained until Contract execution and furnished a performance and payment bond in an amount equal to one hundred percent (100%) of the total Contract price, including an amount estimated to be required for extra work, is furnished.
- The Board reserves the right to hold the bid securities of the four lowest bidders until the successful bidder has entered into a contract and has furnished the required performance bond. All bid securities will be returned in accordance with sub-section 3.5 of the General Conditions.
- Should the successful bidder fail to enter into a contract and furnish a satisfactory performance bond within the time stated in the proposal, the bid security shall be forfeited as required by law.
- H. CONTRACTOR'S LICENSE REQUIRED: The Board will reject all bids received from contractors who have not been licensed by the State Contractors License Board in accordance

with Chapter 444, HRS; Title 16, Chapter 77, Hawaii Administrative Rules; and statutes amendatory thereto.

- I. IRREGULAR BIDS: No irregular bids or propositions for doing the work will be considered by the Board.
- J. WITHDRAWAL OF BIDS: No bidder may withdraw his bid between the time of the opening thereof and the award of contract.
- K. SUCCESSFUL BIDDER TO FILE PERFORMANCE AND PAYMENT BONDS: The successful bidder will be required to file performance and payment bonds each; in the amount equal to the total contract price, including amounts estimated to be required for extra work, as provided in sub-section 3.6 of the General Conditions.
- L. NUMBER OF EXECUTED ORIGINAL COUNTERPARTS OF CONTRACT DOCUMENTS: If requested by the Board, six copies of the Contract, performance and payment bonds shall be executed.
- M. CHANGE ORDERS: No work of any kind in connection with the work covered by the plans and specifications shall be considered as change order work, or entitle the Contractor to extra compensation, except when the work has been ordered in writing by the Chief Engineer (Engineer) and in accordance with sub-section 4.2 of the General Conditions.

The Contractor shall clearly identify and inform the Engineer in writing of any deviations from the contract documents at the time of submission and shall obtain the Engineer's written approval to the specified deviation prior to proceeding with any work.

- N. WAGES AND HOURS: In accordance with sub-sections 7.3 to 7.9 of the General Conditions relative to hours of labor, minimum wages and overtime pay, the current minimum wage rates promulgated by the Department of Labor and Industrial Relations (DLIR) shall be paid to the various classes of laborers and mechanics engaged in the performance of this contract on the job site. The minimum wages shall be increased during the performance of the contract in an amount equal to the increase in the prevailing wages for those kinds of work as periodically determined by the DLIR.

The Department of Land and Natural Resources will not recognize any claim for additional compensation because of the payment by the Contractor of any wage rate in excess of the said minimum wage rates. The possibility of wage increase is one of the elements to be considered by the Contractor in determining his bid, and will not, under any circumstances, be considered as the basis of a claim against the Department under this Contract.

No work shall be done on Saturdays, Sundays, legal State holidays, and/or in excess of eight (8) hours each day without the written consent of the Engineer. Should permission be granted to work at such times, the Contractor shall pay for all inspection administrative costs thereof. No work shall be done at night unless authorized by the Engineer.

- O. PERMITS: The State will process permit applications whenever possible, and the Contractor shall procure the pre-processed permits and pay the required fees. If permit applications are not processed by the State, the Contractor shall process the permit applications, permits and

licenses, and pay all charges and fees. In all cases, the Contractor shall give all notices necessary and incident to the due and lawful prosecution of the work.

- P. PROPERTY DAMAGE: It shall be the responsibility of the contractor to respect State property and to prevent damage to existing improvements. The Contractor will be responsible for damages resulting from construction operations. Immediately upon discovery, the Contractor shall repair such damage to the satisfaction of the Engineer.

All trees and shrubbery outside the excavation, embankment or construction limits shall be fully protected from injury.

- Q. TIME: The time of completion is specified in the Proposal. It is the Board's intention to insist the Contractor diligently prosecute the work to completion within the specified time.

Prospective bidders are reminded that the State has the option to proceed with or abandon a project depending on whether the project can be completed for occupancy in the specified time.

It is the bidder's responsibility to check the availability of all materials before bidding. The bidder shall select sub-contractors and suppliers who can warrant availability and delivery of all specified or qualified materials to assure project completion within the specified time.

The successful bidder must assume all risks for completing the project by the specified date. There shall be no extension of time for any reason except for delays caused by acts of God, labor disputes involving unions, or actions of the State. If for any reason the project falls behind schedule, the Contractor shall at its own cost, take necessary remedial measures to get the project back on schedule, i.e., working overtime, air freighting all materials, etc. In addition, if the Contractor fails to fully complete the project by the completion date, Contractor will be required to make the facility usable at its own cost.

- R. BIDDER'S RESPONSIBILITY TO PROVIDE PROPER SUPERINTENDENCE: The successful low bidder shall designate in writing to the Engineer the name of its authorized superintendent (Superintendent), who will be present at the job site whenever any work is in progress. The Superintendent shall be responsible for all work, receiving and implementing instructions from the Engineer in a timely manner. The cost for superintendence shall be considered incidental to the project.

If the Superintendent is not present at the site of work, the Engineer shall have the right to suspend the work as described under sub-section 5.5 c. and 7.20 - Suspension of Work of the General Conditions.

- S. LIQUIDATED DAMAGES: Liquidated damages in the amount specified in the Proposal will be assessed for each and every calendar day from and after the expiration of the time period stated in the Contract for the completion of the project.

- T. HIRING OF HAWAII RESIDENTS: The Contractor shall comply with Act 68, SLH 2010, in the performance and for the duration of this contract. The Contractor shall ensure that Hawaii residents compose not less than eighty percent of the workforce employed to perform the contract work on the project. The eighty percent requirement shall be determined by

dividing the total number of hours worked on the contract by Hawaii residents, by the total number of hours worked on the contract by all employees of the Contractor in the performance of the contract. The hours worked by any Subcontractor of the Contractor shall count towards the calculation for this section. The hours worked by employees with shortage trades, as determined by the Department of Labor and Industrial Relations (DLIR), shall not be included in the calculation for this section.

The requirements shall apply to any subcontract of \$50,000 or more in connection with the Contractor, that is, such Subcontractors must also ensure that Hawaii residents compose not less than eighty percent of the Subcontractor's workforce used to perform the subcontract.

- U. WATER AND ELECTRICITY: The Contractor shall make all necessary arrangements and pay all expenses for water and electricity used in the construction of this project.
- V. PUBLIC CONVENIENCE AND SAFETY: The Contractor shall conduct construction operations with due regard to the convenience and safety of the public at all times. No materials or equipment shall be stored where it will interfere with the safe passage of public traffic. The Contractor shall provide, install, and maintain in satisfactory condition, all necessary signs, flares and other protective facilities and shall take all necessary precautions for the protection of the work and the convenience and safety of the public. The Engineer shall have the right to suspend the performance of the work in accordance with sub-section 7.20 - Suspension of Work of the General Conditions.
- W. WORK TO BE DONE WITHOUT DIRECT PAYMENT: Whenever the contract that the Contractor is to perform work or furnish materials of any kind for which no price is fixed in the contract, it shall be understood that the Contractor shall perform such work or furnish said materials without extra charge or allowance or direct payment of any sort. The cost of performing such work or furnishing said material is to be included by the Contractor in a unit price for the appropriate item unless it is expressly specified that such work or material is to be paid for as extra work.
- X. AS-BUILT DRAWINGS: As-built drawings, the intent of which is to record the actual in-place construction so that any future renovations or tie-ins can be anticipated accurately, shall be required. All authorizations given by the Engineer to deviate from the plans shall be drawn on the job site plans. All deviations from alignments, elevations and dimensions which are stipulated on the plans shall be recorded on the as-built drawings. Final as-built drawings shall be submitted to the Engineer for review and approval. After the Engineer approves the as-built drawings, the contractor shall submit an electronic copy in Adobe PDF format on CD ROM.
- Y. ASBESTOS CONTAINING MATERIALS: The use of asbestos containing materials or equipment is prohibited. The Contractor shall insure that all materials and equipment incorporated in the project are asbestos-free
- Z. WORKER SAFETY: The Contractor shall provide, install and maintain in satisfactory condition all necessary protective facilities and shall take all necessary precautions for the protection and safety of its workers in accordance with the Occupational Safety and Health Standards for the State of Hawaii. The Engineer shall have the right to suspend the performance of the work in accordance with sub-section 7.20 - Suspension of Work of the

General Conditions.

- AA. TOILET FACILITIES: All toilet facilities constructed at the project site shall be in accordance with the Public Health Regulations of the State Department of Health (DOH). All necessary precautions shall be observed at the project site. The use of sanitary facilities shall be strictly enforced and workers violating these provisions shall be promptly discharged.
- BB. SIGNS: Whenever the project involves closing or obstructing any public thoroughfare, the Contractor shall provide traffic signs conforming to the applicable provisions of the current edition of the "Manual on Uniform Traffic Control Devices for Streets and Highways", published by the Federal Highway Administration as directed by the Engineer for the purpose of diverting or warning traffic prior to the construction area. All traffic signs shall bear proper wording stating thereon the necessary information as to diverting or warning traffic.

When indicated in the Proposal, the Contractor shall provide a project sign, size 4'-0" x 7'-0" to be placed as directed by the Engineer. The sign shall be constructed in accordance with Section 01581 - Project Sign of these specifications and approved by the Engineer. All wording, type and size of lettering and color selection shall be as specified in these specifications or as approved by the Engineer.

All signs shall be kept neat and clean, and properly erected at all times.

- CC. FIELD OFFICE AREA FOR DEPARTMENT: When indicated in the Proposal, the Contractor shall provide a housed working area of at least 100 square feet adjacent to the Contractor's office for the Department's use. This area will be used by the Engineer to perform tests and to store equipment. As a minimum, the field office shall include the following: standard sized office desk and chair, lighting, ventilation, window-type air conditioning rated at 5,000 BTU, door and window with locking hardware, electrical outlets, and working communications facilities (a cellular telephone is acceptable). The Department will pay for all long distance toll charges made by the Engineer.
- DD. QUANTITIES: All bids will be compared on the basis of quantities of work to be done as shown in the Proposal; the quantities shown in the Unit Price items are estimated, being given as a basis for comparison of bids. The Board reserves the right to increase or decrease the quantities given under the items or delete items entirely as may be required during the progress of the work.
- EE. OTHER HEALTH MEASURES: Forms of work site exposure or conditions which may be detrimental to the health or welfare of workers or of the general public shall be eliminated or reduced to safe levels as required by the DOH codes, standards, and regulations. Suitable first aid kits and a person qualified to render first aid, as specified in the DOH regulations, shall be provided at all times when work is scheduled.
- FF. HAWAII BUSINESS OR COMPLIANT NON-HAWAII BUSINESS REQUIREMENT: Bidders (Contractors) shall be incorporated or organized under the laws of the State or be registered to do business in the State as a separate branch or division that is capable of fully performing under the contract, as stipulated in §3-122-112 HAR.

GG. COMPLIANCE WITH §3-122-112 HAR:

As a condition for award of the contract and as proof of compliance with the requirements of 103D-310(c) HRS, the apparent low bidder shall furnish the required documents to the Department. If the valid required certificates are not submitted on a timely basis for award of a contract, a bidder otherwise responsive and responsible may not receive the award. Bidder is responsible to apply for and submit the following documents to the Department.

- A. **TAX CLEARANCE REQUIREMENTS (HRS Chapter 237):** Bidder shall obtain a tax clearance certificate from the Hawaii State Department of Taxation (DOTAX) and the Internal Revenue Service (IRS). The certificate is valid for six months from the most recently approved stamp date on the certificate; the certificate must be valid on the date received by the Department.
- B. Department of Labor (DLIR) **“Certificate of Compliance”**. (HRS Chapter 383 - Unemployment Insurance, Chapter 386 - Workers’ Compensation, Chapter 392 - Temporary Disability Insurance, and 393 – Prepaid Health Care): Bidder shall obtain a certificate of compliance from the Hawaii State Department of Labor and Industrial relations (DLIR). The certificate is valid for six months from the date of issue; certificates must be valid on the date received by the Department.
- C. Department of Commerce and Consumer Affairs (DCCA), Business Registration Division (BREG) **“Certificate of Good Standing”**. Bidder shall obtain a certificate of good standing issued by the Department of Commerce and Consumer Affairs (DCCA), Business Registration Division (BREG). The certificate of good standing is valid for six months from the date of issue; certificates must be valid on the date received by the Department.

Alternately, instead of separately applying for these certificates at the various state agencies, bidder may choose to use the Hawaii Compliance Express (HCE), which allows businesses to register online through a simple wizard interface at <http://vendors.ehawaii.gov> to acquire a “Certificate of Vendor Compliance” indicating the bidder’s status is compliant with the requirements of §103D-310(c), HRS, and shall be accepted for contracting and final payment purposes. Bidders that elect to use the new HCE services will be required to pay an annual fee of \$12.00 to the Hawaii Information Consortium, LLC (HIC). Bidders choosing not to participate in the HCE program will be required to provide the paper certificates as instructed in the previous paragraphs.

PROPOSAL

FOR

DEPARTMENT OF LAND AND NATURAL RESOURCES
ENGINEERING DIVISION
State of Hawaii

JOB NO. F27C793B
HEEIA STATE PARK
REPAIRS TO SERVICE ROAD
KANEEOHE, OAHU, HAWAII

_____, 20__

Chief Engineer
Engineering Division
Department of Land and Natural Resources
State of Hawaii
Honolulu, Hawaii

Dear Sir:

The undersigned, having carefully examined the local conditions and all available records and information covering conditions which may affect the cost of the work to be performed, and having carefully examined the Plans and Specifications, and other contract documents, hereby proposes to furnish and pay for all materials, tools, equipment, labor and other incidental work necessary to resurface the existing service road, build a gravel turning area, replace and install posts with chain barrier, as required or called for in this Proposal, all according to the true intent and meaning of the Notice to Bidders, Information and Instructions to Bidders, Proposal, Detailed Specifications, Interim General Conditions, Plans, and any and all addenda for:

JOB NO. F27C793B
HEEIA STATE PARK
REPAIRS TO SERVICE ROAD
KANEEOHE, OAHU, HAWAII

on file in the office of the Engineering Division for the TOTAL BASE BID (Items 1 to 11) of:

_____ Dollars (\$_____)

and will fully complete all work under this contract within 30 consecutive calendar days from the date of written notice to proceed, including date of said order, said total sum being itemized on the following pages.

PROPOSAL

Item No.	Quantity	Unit	Description	Unit Price	Total
1.		LS	Demolition, Hauling and Disposal	LS	\$ _____
2.		LS	Clearing & Grubbing	LS	\$ _____
3.		LS	Pollution/Erosion Control	LS	\$ _____
4.	180	SY	2" Thick Asphalt Concrete Pavement	\$ _____	\$ _____
5.	180	SY	6" Aggregate Base Course	\$ _____	\$ _____
6.		LS	Posts with Chain Barrier	LS	\$ _____
7.	55	LF	Root Barrier Installation	\$ _____	\$ _____
8.	6.5	CY	Earthwork – Cut	\$ _____	\$ _____
9.	1.5	CY	Earthwork – Fill	\$ _____	\$ _____
10.	1	EA	Project Sign, in place complete.	\$ _____	\$ _____
			Subtotal Base Bid (Items 1-10)		\$ _____
11.		LS	Mobilization and Demobilization (not to exceed 10% of the Subtotal Base Bid)		\$ _____
			Total Base Bid (Items 1-11)		\$ _____
			<u>ADDITIVE NO. 1 (GRAVEL ROAD)</u>		
12.	170	SY	3" Compacted Base Course	\$ _____	\$ _____
13.		LS	Scarify Ground	LS	\$ _____
			Total Sum Additive No. 1 (Items 12-13)		\$ _____
			<u>ADDITIVE NO. 2</u>		
14.		LS	Tree Root Removal	LS	\$ _____
			Total Sum Additive No. 1 (Items 14)		\$ _____

HAWAII PRODUCTS PREFERENCE AND/OR USE OF HAWAII PRODUCTS

In accordance with Act 175, SLH 2009, the Hawaii products preference is applicable to this solicitation. Bidders offering a Hawaii product (“HP”) shall identify the HP in the table below.

Persons desiring to qualify their product(s) not currently on the Hawaii Product List, shall complete Form SPO-38, *Certification for Hawaii Product Preference*, and submit the completed form no later than the deadline specified in the procurement notice and solicitation. The responsibility for certification and qualification shall rest upon the person requesting the preference. One form shall be completed and submitted for each product. Form SPO-38 is available at <http://hawaii.gov/spo/>

For the purpose of selecting the low bid when a solicitation contains both HP and non-HP, the price offered for a HP item shall be decreased by subtracting 10% for the class I or 15% for the class II HP item(s) offered. The lowest total offer, taking the preference into consideration, shall be awarded the contract, unless the offer provides for additional award criteria. The contract amount of any contract awarded, however, shall be the amount of the price offered, exclusive of the preferences.

In the event of any change that materially alters the bidder’s ability to supply the Hawaii product(s), the bidder shall immediately notify the procurement officer in writing and the parties shall enter into discussions for the purpose of revising the contract or terminating the contract for convenience.

Item No.	Pre-Approved Hawaii Product Description & Manufacturer	Class (I or II)	Quantity	Unit Measure	Unit Price	Total Price
1.	<i>[Product Description, Manufacturer Name]</i>	(I)				
2.						
3.						
4.						

RECYCLED PRODUCTS PREFERENCE

This project allows a 10% price preference for recycled products in accordance with HRS 103D-1005. Please indicate your selection of recycled or non-recycled product by indicating its cost FOB jobsite unloaded in the schedule below, including applicable General Excise & Use Taxes.

<u>DESCRIPTION</u>	<u>RECYCLED PRODUCT COST</u>	<u>NONRECYCLED PRODUCT COST</u>
_____	\$ _____	\$ _____
_____	\$ _____	\$ _____
_____	\$ _____	\$ _____
_____	\$ _____	\$ _____

The bidder requesting a recycled product preference shall also complete and submit the form "CERTIFICATION OF RECYCLED CONTENT" as shown in the Interim General Conditions and provide all supporting information with this proposal. Additional information may be requested to qualify a product.

The following definitions are applicable to the CERTIFICATION OF RECYCLED CONTENT form:

"Post-consumer recovered material" means any product used by a consumer, including a business that purchases the material, that has served its intended end use, and that has been separated or diverted from the solid waste stream for the purpose of use, reuse, or recycling.

"Product" includes materials, manufactures, supplies, merchandise, goods, wares, and foodstuffs.

"Recovered material" means waste material and by-products that have been separated, diverted, or removed from the solid waste stream after a manufacturing process for the purpose of use, reuse, or recycling. Recovered material does not include those materials and by-products that are generated and normally reused on-site or within original manufacturing processes (such as mill broke, in the case of paper products).

"Recycled content" means the percentage of a product composed of recovered material, or post-consumer recovered material, or both.

"Recycled product" means a product containing recovered material, or post-consumer recovered material, or both.

The bidder agrees that preference for recycled products shall be taken into consideration to determine the low bidder in accordance with said Section and the rules promulgated, however, the award of contract will be in the amount of the bid offered exclusive any preference.

CONTRIBUTIONS BY STATE AND COUNTY CONTRACTORS PROHIBITED

Contractors are hereby notified of the applicability of Section 11-355, HRS, which states that campaign contributions are prohibited from specified State or county government contractors during the term of the contract if the contractors are paid with funds appropriated by a legislative body.

CONDITION OF AWARD

It is understood that the award of the contract will be made on the basis of the lowest responsible Total Base Bid (Items 1 to 11) selected by the Board of Land and Natural Resources. Write the total of bid items 1 to 11 on page P-1.

In the event the low bid is below the available funds certified by the appropriate fiscal officer, the head of the purchasing agency responsible for the procurement in question is authorized to award Additives to the lowest bidder. The award of Additives may be in any order or combination such that the Base Bid plus Additives do not exceed the available funds.

It is understood and agreed that the Board of Land and Natural Resources reserves the right to reject any and/or all bids and waive any defects when, in the Board's opinion, such rejection or waiver will be for the best interest of the State of Hawaii.

In the event all bids exceed available funds certified by the appropriate fiscal officer, the head of the purchasing agency responsible for the procurement in question is authorized in situations where time or economic considerations preclude resolicitation of work of a reduced scope to negotiate an adjustment of the bid price, including changes in the bid requirements, with the low responsible and responsive bidder, in order to bring the bid within the amount of available funds. It is understood and agreed upon that the head of the purchasing agency may delete a portion or all of any item(s) in the proposal at the stated unit or lump sum price as necessary to stay within the available funding. The bidder is responsible to make an earnest effort to represent the actual cost of each item, including all materials, labor, equipment, overhead and profit in their bid proposal to preclude claims of anticipated profit or loss of profit because of an unbalanced bid proposal.

It is also understood that if a mutually agreeable cost for the reduced scope of work necessitated by a lack of available funds cannot be agreed upon between the bidder and the head of the purchasing agency within 14 calendar days after the bid opening, then the bid may be rejected in the best interest of the purchasing agency, and the head of the purchasing agency may negotiate in progressive order (lowest to highest) with the next lowest responsible and responsive bidder.

It is also understood and agreed that the award of the contract shall be conditioned upon funds being made available for this project and further upon the right of the Board of Land and Natural Resources to hold all bids received for a period of sixty (60) days from the date of the opening thereof, unless otherwise required by law, during which time no bid may be withdrawn.

It is also understood that Notice to Proceed may be delayed up to one (1) year after the bid opening date, and that no additional compensation will be provided for any claim for escalation or delay for issuance of Notice to Proceed on or before that date.

It is also understood and agreed that the quantities given herewith are approximate only and are subject to increase or decrease, and that the undersigned will perform all quantities of work as either increased or decreased, in accordance with the provisions of the Contract Specifications.

It is also understood and agreed that the estimated quantities shown for the items for which a UNIT PRICE is asked in this Proposal are only for the purpose of comparing on a uniform basis, bids offered for the work under this contract, and the undersigned agrees that he is satisfied with and will at no time, dispute said estimated quantities as a means of claims for anticipated profit or loss of profit, because of a difference between the quantities of the various classes of work done or the materials and equipment installed, and the said estimated quantities. On UNIT PRICE bids, payment will be made only for the actual number of units incorporated into the finished project at the contract UNIT PRICE.

After the proposals are opened and read, the figures will be extended and/or totaled in accordance with the bid prices of the acceptable proposals and the totals will be compared. In the comparison of bids, words written in the proposal shall govern over figures and unit prices will govern over totals. Until the award of the contract, however, the right will be reserved to reject any and all proposals and to waive any defects or technicalities as may be deemed best for the interest of the State.

It is also understood and agreed that liquidated damages in the amount One Hundred and No/100 Dollars (\$ 100.00) for each and every calendar day in excess thereof prior to completion of the contract shall be withheld from payments due to the Contractor.

It is also understood and agreed that if this bid is accepted, the successful bidder must enter into and execute a contract with the Board of Land and Natural Resources and furnish a Performance and Payment Bond, as required by law. These bonds shall conform to provisions of Section 103D-324 and 325, Hawaii Revised Statutes and any law applicable hereto.

It is also understood and agreed that the successful bidder will provide all necessary labor, materials, tools, equipment, and other incidentals necessary to do all the work and furnish all the materials specified in the contract in the manner and time herein prescribed, and according to the requirements of the Engineer as therein set forth.

It is understood that by submitting this proposal, the undersigned is declaring that his firm has not been assisted or represented on this matter by an individual who has, in a State capacity, been involved in the subject matter of this contract in the past two years.

It is understood that by submitting this proposal in accordance with HAR 3-122-192, the undersigned is declaring that the price submitted is independently arrived without collusion.

It is also understood that by submitting this proposal, a Certification for Safety and Health Programs for bids in excess of \$100,000 (in accordance with HRS 396-18), the undersigned certifies that his organization will have a written safety and health plan for this project that will be available and implemented by the Notice to Proceed date of this project. Details of the requirements of this plan may be obtained from the Department of Labor and Industrial Relations, Occupational, Safety and Health Division (HIOSH).

It is further understood and agreed that the successful bidder shall comply with paragraph 3.1.a "SUBCONTRACTING" of the General Provisions which requires that the contractor shall perform with his own organization and with the assistance of workmen under his immediate superintendence, work of a value not less than twenty percent (20%) of the value of all work embraced in the Contract, except that certain contract items of work, if specifically referred to in the special provisions, will be exempted from said twenty percent requirement.

Compliance with §103-310 HRS. As a condition of award all bidders shall comply with all laws governing entities doing business in the State, including Chapter 237 HRS (general excise tax); Chapter 383 HRS (employment security – unemployment insurance); Chapter 386 HRS (workers compensation); Chapter 392 HRS (temporary disability insurance); and Chapter 393 HRS (pre-paid health care), and shall produce all documents to the State (DLNR, Engineering Division) required to demonstrate compliance with these subsections. Any bidder making a false affirmation or certification under this subsection shall be suspended and may be debarred from further offerings or awards pursuant to §103D-702 HRS.

RECEIPT OF ADDENDA

The bidder also acknowledges receipt of any and all addenda issued by the Engineering Division, by recording the date of receipt of the respective addenda in the space provided below:

<u>Addendum</u>	<u>Date Received</u>	<u>Addendum</u>	<u>Date Received</u>
No. 1	_____	No. 5	_____
No. 2	_____	No. 6	_____
No. 3	_____	No. 7	_____
No. 4	_____	No. 8	_____

It is understood that failure to receive any such addendum shall not relieve the Contractor from any obligation under this Proposal as submitted.

It is also understood and agreed that if this Proposal is accepted and the undersigned should fail or neglect to contract as aforesaid, the Board may determine that the bidder has abandoned the Contract, and thereupon, forfeiture of the security accompanying his proposal shall operate and the same shall become the property of the Board.

JOINT CONTRACTORS OR SUBCONTRACTORS
TO BE ENGAGED ON THIS PROJECT

The Bidder agrees that the following is a complete listing of all joint contractors or subcontractors covered under Chapter 444, Hawaii Revised Statutes (HRS), who will be engaged by the Bidder on this project to perform the required work indicated pursuant to Section 103D-302, HRS. It is the sole responsibility of the contractor to review the requirements of this Project and determine the appropriate licenses that are required to complete the Project. The Bidder certifies that the completed listing of joint contractors or subcontractors fulfills the requirements for the project and the Bidder, together with the listed subcontractors or joint contractors have all the specialty contractor's licenses to complete the work, except as provided for in HRS §103D-302(b). Failure of the Bidder to comply with this requirement may be just cause for rejection of the bid.

“A” General Engineering Contractors and “B” General Building Contractors are reminded that due to the Hawaii Supreme Court’s January 28, 2002 decision in Okada Trucking Co., Ltd. v. Board of Water Supply, et al., 97 Haw. 450 (2002), they are prohibited from undertaking any work, solely or as part of a larger project, which would require the general contractor to act as a specialty contractor in any area in which the general contractor has no license. Although the “A” and “B” contractor may still bid on and act as the “prime” contractor on an “A” or “B” project (See, HRS §444-7 for the definitions of an “A” and “B” project.), respectively, the “A” and “B” contractor may only perform work in the areas in which they have the appropriate contractor’s license (*An “A” or “B” contractor obtains “C” specialty contractor’s licenses either on its own, or automatically under HAR § 16-77-32*). The remaining work must be performed by appropriately licensed entities.

General Engineering “A” Contractors automatically have these “C” specialty contractor’s licenses: C-3, C-9, C-10, C-17, C-24, C-31a, C-32, C-35, C-37a, C-37b, C-38, C-43, C-49, C-56, C-57a, C-57b and C-61.

General Building “B” Contractors automatically have these “C” specialty contractor’s licenses: C-5, C-6, C-10, C-12, C-24, C-25, C-31a, C-32a, C-42a and C-42b.

In completing the Joint Contractors or Subcontractors List, describe the specialty contractor’s nature and scope of work to be performed for this project and provide the complete firm name of the joint contractor or subcontractor in the respective columns. If the Bidder is a general contractor and providing the work of the required specialty contractor, fill in the Bidder’s (general contractor’s) name and nature and scope of work to be performed on this project.

List only one joint contractor or subcontractor per required specialty contractor’s classification, unless within the same specialty, the work of each joint contractor or subcontractor can be described so that there is no overlap in work descriptions.

If a contractor’s license is required by law for the performance of the work which is called for in this bid, the bidder and all subcontractors must have the required license before the submission of the bidder’s proposal in the case of a non-federal aid project, and for federal-aid projects, the bidder must have the required license prior to the award of the project and all subcontractors prior to the start of the subcontracted work.

JOINT CONTRACTORS OR SUBCONTRACTORS LIST FOR THE ADDITIVE(S):

Bidder agrees that for projects with additives(s), the Bidder, joint contractor or subcontractor listed in the completed “Joint Contractors or Subcontractors List for the Additives(s)” will perform work for the respective additives.

Additive 1

COMPLETE FIRM NAME OF JOINT CONTRACTOR OR SUBCONTRACTOR	NATURE AND SCOPE OF WORK TO BE PERFORMED

Note: Provide similar tables for each additive.

JOINT CONTRACTORS OR SUBCONTRACTORS LIST FOR THE ADDITIVE(S):

Bidder agrees that for projects with additives(s), the Bidder, joint contractor or subcontractor listed in the completed “Joint Contractors or Subcontractors List for the Additives(s)” will perform work for the respective additives.

Additive 2

COMPLETE FIRM NAME OF JOINT CONTRACTOR OR SUBCONTRACTOR	NATURE AND SCOPE OF WORK TO BE PERFORMED

Note: Provide similar tables for each additive.

Enclosed herewith is a:

- 1. Surety Bond (*1))
- 2. Legal Tender (*2))
- 3. Cashier's Check (*3))
- 4. Certificate of Deposit (*3)) in the
- 5. Certified Check (*3)) amount
- 6. Official Check (*3)) of
- 7. Share Certificate (*3))
- 8. Teller's Check (*3))
- 9. Treasurer's Check (*3))

(Cross Out Those Not Applicable)

Dollars (\$ _____)

as required by law.

Respectfully submitted,

Name of Company, Joint Venture
or Partnership

Contractor's License No.

By _____
Signature (*4)

Title _____

Print Name _____

Date _____

Address _____

Telephone No. _____

E-Mail Address _____

NOTES:

1. Surety bond underwritten by a company licensed to issue bonds in this State;
2. Legal tender; or
3. A certificate of deposit; share certificate; or cashier's, treasurer's, teller's, or official check drawn by, or a certified check accepted by, and payable on demand to the State by a bank, a savings institution, or credit union insured by the Federal Deposit Insurance Corporation or the National Credit Union Administration.
 - A. These instruments may be utilized only to a maximum of \$100,000.
 - B. If the required security or bond amount totals over \$100,000, more than one instrument not exceeding \$100,000 each and issued by different financial institutions shall be accepted.
4. Please attach to this page evidence of the authority of this officer to submit bids on behalf of the Company and also the names and residence addresses of all officers of the Company.
5. Fill in all blank spaces with information asked for or bid may be invalidated. PROPOSAL MUST BE INTACT, MISSING PAGES MAY INVALIDATE YOUR BID.

End of Proposal

SPECIAL PROVISIONS

Amend INTERIM GENERAL CONDITIONS, dated October 1994, as follows:

Section 2 – Proposal Requirements and Conditions

1. **AMEND** Section 2.1 Qualification of Bidder with the following:

Written Notice of Intent to Bid or Offer: A written Notice of Intent to Bid is not required for the Solicitation.

Standard Qualification Questionnaire: Bidders may be required to complete a standard qualifications questionnaire. When requested, the information shall be furnished within two working days or longer at the discretion of the Engineer. Failure to furnish the requested information within the time allowed may be grounds for a determination of non-responsibility, in accordance with HRS Section 103D-310 and HAR Section 3-122-108.

Hawaii Business or Compliant Non-Hawaii Business Requirement: Bidders shall be incorporated or organized under the laws of the State or be registered to do business in the State as a separate branch or division that is capable of fully performing under the contract, as stipulated in §3-122-112 HAR. A certified letter is not required prior to bid opening.

Compliance with §3-122-112 HAR: As a condition for award of the contract and as proof of compliance with the requirements of 103D-310(c) HRS, the apparent low bidder shall furnish the required documents to the Department. If the valid required certificates are not submitted on a timely basis for award of a contract, a bidder otherwise responsive and responsible may not receive the award. Bidder is responsible to apply for and submit the following documents to the Department.

- A. Tax Clearance (HRS Chapter 237): Bidder shall obtain a tax clearance certificate from the Hawaii State Department of Taxation (DOTAX) and the Internal Revenue Service (IRS). The certificate is valid for six months from the most recently approved stamp date on the certificate; the certificate must be valid on the date received by the Department.
- B. Department of Labor (DLIR) “Certificate of Compliance”. (HRS Chapter 383 - Unemployment Insurance, Chapter 386 - Workers’ Compensation, Chapter 392 - Temporary Disability Insurance, and 393 – Prepaid Health Care): Bidder shall obtain a certificate of compliance from the Hawaii State Department of Labor and Industrial relations (DLIR). The certificate is valid for six months from the date of issue; certificates must be valid on the date received by the Department.
- C. Department of Commerce and Consumer Affairs (DCCA), Business Registration Division (BREG) “Certificate of Good Standing”. Bidder shall obtain a certificate of good standing issued by the Department of Commerce and Consumer Affairs (DCCA), Business Registration Division (BREG). The certificate of good standing is valid for six months from the date of issue; certificates must be valid on the date received by the Department.

Hawaii Compliance Express. Alternately, instead of separately applying for these certificates at the various state agencies, bidder may choose to use the Hawaii Compliance Express (HCE), which allows businesses to register online through a simple wizard interface at <http://vendors.hawaii.gov> to acquire a “Certificate of Vendor compliance” indicating that bidder’s status is compliant with requirements of §103D-310(c), HRS, shall be accepted for contracting and final payment purposes.

Bidders that elect to use the new HCE services will be required to pay an annual fee of \$15.00 to the

Hawaii Information Consortium, LLC (HIC). Bidders choosing not to participate in the HCE program will be required to provide the paper certificates as instructed in the previous paragraphs.

2. **ADD** Section 2.4a, Pre-Bid Conferences

Required Pre-bid Conferences: For construction and design-build projects with an estimated value of \$500,000 or more and solicited under the competitive sealed bid method (103D-302 HRS); and for construction and design-build projects with an estimated value of \$100,000 or more and solicited under the competitive sealed proposal method (103D-303 HRS); a pre-bid conference is required.

Other Pre-Bid Conferences: The Department may require a pre-bid conference for construction or design-build projects that are below the dollar threshold listed in above or when projects have special or unusual requirements.

Other Conditions: The Department may require the prospective Bidders to make a physical inspection of the project site and make attendance at the pre-bid conference a condition for submitting an offer.

Nothing stated at the pre-bid conference shall change the solicitation unless a change is made by written addendum.

3. **DELETE** Section 2.5, Addenda and Interpretations, in its entirety and replace with the following:

“Discrepancies, omissions, or doubts as to the meaning of drawings and specifications should be communicated using the question and answer section on the HIEPRO solicitation for interpretation and must be received in the time frame set in the HIEPRO solicitation. Any interpretation, if made and any supplemental instructions will be in the form of written addenda to the plans and specifications and made available prior to the offer due date. It shall be the prospective bidder’s sole responsibility to verify and obtain any said addenda. Failure of any bidder to receive any such addendum or interpretation shall not relieve such bidder from any obligation under his bid as submitted. All addenda so issued shall become part of the contract documents.”

Section 3 – Award and Execution of Contract

1. **AMEND** Section 3.3, Award of Contract, by deleting “sixty (60)” and replacing with “ninety (90)” in the first paragraph.

2. **AMEND** Section 3.3, Award of Contract, by adding the following after the first paragraph:

“If the contract is not awarded within the ninety (90) days, the Department may request the successful Bidder to extend the time for the acceptance of its bid. The Bidder may reject such a request without penalty; and in such case, the Department may at its sole discretion make a similar offer to the next lowest responsive and responsible bidder and so on until a bid is duly accepted or until the Department elects to stop making such requests.”

3. **AMEND** Section 3.9, Notice to Proceed, by deleting “180 days” and replacing with “one (1) year” in the last paragraph.

4. **ADD** Section 3.10, Protests:

“3.10 PROTESTS—Pursuant to Section 103D-701, Hawaii Revised Statutes, an actual or prospective offeror who is aggrieved in connection with the solicitation or award may submit a protest. Any protest

shall be submitting in writing to the Chairperson, Department of Land and Natural Resources, 1151 Punchbowl Street, Honolulu, Hawaii 96813, or designee as specified in the solicitation.

A protest shall be submitted in writing within five (5) working days after the aggrieved person knows or should have known the facts giving rise thereto; provided that a protest based upon the content of the solicitation shall be submitted in writing prior to the date set for receipt of offers. Further provided that a protest of an award or proposed award shall be submitted within five (5) working days after the posting of the award of the contract.

The notice of award, if any, resulting from this solicitation shall be posted on the Procurement System on the SPO website: <http://hawaii.gov/spo2/>.

Section 5 – Control of Work

AMEND Section 5.8 Value Engineering Incentive by deleting “\$100,000” and replacing with “\$250,000” in the first paragraph.

Section 6 – Substitution of Materials and Equipment

ADD the following to Section 6.3 Sub-paragraph b:

4. If the substitution meets all the requirements of the specifications and plans.

Section 7 – Prosecution and Progress

1. **DELETE** Section 7.2d in its entirety and replace with the following:

“d. Insurance Requirements

1. Obligation of Contractor

The Contractor shall not commence any work until it obtains, at its own expense, all required insurance. Such insurance must have the approval of the Department as to limit, form and amount and must be maintained with a company authorized by law to issue such insurance in the State of Hawaii.

All insurance described herein will be maintained by the Contractor for the full period of the contract and in no event will be terminated or otherwise allowed to lapse prior to written certification of final acceptance of the work by the Department.

Certificate(s) of Insurance acceptable to the Department shall be filed with the Engineer prior to commencement of the work. These certificates shall contain a provision that coverages afforded under the policies will not be canceled or changed until at least thirty days written notice has been given to the Engineer by registered mail. The insurance policies shall name the State of Hawaii, its officers and employees as an additional insured and such coverage shall be noted on the Certificate. Should any policy be canceled before final acceptance of the work by the Department, and the Contractor fails to immediately procure replacement insurance as specified, the Department, in addition to all other remedies it may have for such breach, reserves the right to procure such insurance and deduct the cost thereof from any money due to the Contractor.

Nothing contained in these insurance requirements is to be construed as limiting the extent of Contractor's responsibility for payment of damages resulting from its operations under this contract, including the Contractor's obligation to pay liquidated damages, nor shall it affect the Contractor's separate and independent duty to defend, indemnify and hold the Department harmless pursuant to other provisions of this contract. In no instance will the Department's exercise of an option to occupy and use completed portions of the work relieve the Contractor of its obligation to maintain the required insurance until the date of final acceptance of the work.

All insurance described herein shall cover the insured for all work to be performed under the contract, all work performed incidental thereto or directly or indirectly connected therewith, including traffic detour work or other work performed outside the work area, and all change order work.

The Contractor shall, from time to time, furnish the Engineer, when requested, satisfactory proof of coverage of each type of insurance required or a copy of the actual policies covering the work. Failure to comply with the Engineer's request may result in suspension of the work, and shall be sufficient grounds to withhold future payments due the Contractor and to terminate the contract for Contractor's default.

2. Types of Insurance

The Contractor shall purchase and maintain insurance described below which shall provide coverage against claims arising out of the Contractor's operations under the contract, whether such operations be by the Contractor itself or by the subcontractor or by anyone directly or indirectly employed by any of them or by anyone for whose acts any of them may be liable.

- (a) Worker's Compensation. The Contractor and all subcontractors shall obtain full worker's compensation insurance coverage for all persons whom they employ or may employ in carrying out the work under this contract. This insurance shall be in strict conformity with the requirements of the most current and applicable State of Hawaii Worker's Compensation Insurance laws in effect on the date of the execution of this contract and as modified during the duration of the contract.
- (b) Commercial General Liability Insurance and Automobile Insurance. Contractor's commercial general liability insurance and automobile liability insurance shall both be obtained in a combined, single limit of not less than \$1,000,000 per occurrence that shall include coverage for bodily injury, sickness, disease or death of any person, arising directly or indirectly out of, or in connection with, the performance of work under this contract.

The Contractor's property damage liability insurance shall provide for a single combined limit of not less than \$1,000,000 for all damages arising out of injury to or destruction of property of others including the Department's, arising directly or indirectly out of or in connection with the performance of the work under this contract including explosion or collapse.

The Contractor shall either:

- i. Require each of its subcontractors to procure and to maintain during the life of its subcontract, subcontractors' comprehensive general liability, automobile liability

and property damage liability insurance of the type and in the same amounts specified herein; or

- ii. Insure the activities of its subcontractors in its own policy.

The Contractor will be permitted, in cooperation with insurers, to maintain a self insured retention for up to 25% of the per occurrence combined single limits of the commercial general liability and the automobile liability policies. The existence of the self insured retention must be noted on the certificate of insurance coverage submitted to the Department or else it will be understood that the insurer is providing first dollar coverage for all claims. For all claims within the self-insured retention amount, the rights, duties and obligations between the Contractor and the Department shall be identical to that between a liability insurer and the Department, as an additional insured, as if there was no self-insured retention.

- (c) Builder's Risk Insurance. Unless included in the Specifications of this project, the Contractor shall not be required to provide builder's risk insurance. If required as noted in the Specifications, builder's risk insurance shall be provided during the progress of work and until final acceptance by the Department upon completion of the contract. It shall be "All Risk" (including but not limited to earthquake, windstorm and flood damage) completed value insurance coverage on all completed work and work in progress to the full replacement value thereof. Such insurance shall include the Department as additional name insured. The Contractor shall submit to the Engineer for its approval all items deemed to be uninsurable. The policy may provide for a deductible in an amount of up to 25% of the amount insured by the policy. With respect to all losses up to any deductible amount, the relationship between the Contractor and the Department shall be that of insurer and additional insured as if no deductible existed".

2. **DELETE** Section 7.16 in its entirety and replace with the following:

"RESPONSIBILITY FOR DAMAGE CLAIMS; INDEMNITY – The Contractor shall indemnify the State and the Department against all loss of or damage to the State's or the Department's existing property and facilities arising out of any act or omission committed in the performance of the work by the Contractor, any subcontractor or their employees and agents. Contractor shall defend, hold harmless and indemnify the Department and the State, their employees, officers and agents against all losses, claims, suits, liability and expense, including but not limited to attorneys' fees, arising out of injury to or death of persons (including employees of the State and the Department, the Contractor or any subcontractor) or damage to property resulting from or in connection with performance of the work and not caused solely by the negligence of the State or the Department, their agents, officers and employees. The State or the Department may participate in the defense of any claim or suit without relieving the Contractor of any obligation hereunder. The purchase of liability insurance shall not relieve the Contractor of the obligations described herein.

The Contractor agrees that it will not attempt to hold the State and its Departments and Agencies and their officers, representatives, employees or agents, liable or responsible for any losses or damages to third parties from the action of the elements, the nature of the work to be done under these specifications or from any unforeseen obstructions, acts of God, vandalism, fires or encumbrances which may be encountered in the prosecution of the work.

The Contractor shall pay all just claims for materials, supplies, tools, labor and other just claims against the Contractor or any subcontractor in connection with this contract and the surety bond will not be

released by final acceptance and payment by the Department unless all such claims are paid or released. The Department may, but is not obligated to, withhold or retain as much of the monies due or to become due the Contractor under this contract considered necessary by the Engineer to cover such just claims until satisfactory proof of payment or the establishment of a payment plan is presented.

The Contractor shall defend, indemnify and hold harmless the State and its Departments and Agencies and their officers, representatives, employees or agents from all suits, actions or claims of any character brought on account of any claims or amounts arising or recovered under the Worker's Compensation Laws or any other law, by-law, ordinance, order or decree.

Section 8 – Measurement and Payment

1. **DELETE** Section 8.7a in its entirety and replace with the following:

- a. Tax Clearances from the State of Hawaii Department of Taxation and Internal Revenue Service, subject to section 103D-328, HRS, current within two months of issuance date indicating that all delinquent taxes levied or accrued under State Statutes against the contractor have been paid.

2. **ADD** Section 8.7d, Certificate of Compliance:

- d. A Certification from the Contractor affirming that the Contractor has, as applicable, remained in compliance with all laws as required by Section 103D-310, HRS, and Section 3-122-112, HAR. A contractor making a false affirmation shall be suspended and may be debarred pursuant to section 103D-702, HRS.

1. Certification of Compliance for Final Payment, State Procurement Office Form-22. Must be Signed Original.

3. **ADD** Section 8.7e, Hawaii Compliance Express:

- e. In lieu of submitting the tax clearances from Taxation and IRS, and SPO Form -22, the Contractor may choose to use the Hawaii Compliance Express as described on page SP-1 of this Special Provisions.

TABLE OF CONTENTS

TECHNICAL SPECIFICATIONS	SECTION NO.
<i>DIVISION 1 – GENERAL REQUIREMENTS</i>	
General Specifications	01019
Standard references	01090
Archaeological Protection	01100
Submittals	01300
Mobilization and Demobilization	01505
Barricades	01530
Pollution Control	01567
Project Sign	01581
<i>DIVISION 2 – SITEWORK</i>	
Site Preparation	02100
Clearing and Grubbing	02110
Earthwork	02200
Trenching, Backfilling, and Compacting	02225
Roadway Excavation	02226
Aggregate Basecourse	02230
Soil Treatment for Vegetation Control	02362
Asphaltic Concrete	02512
Tack Coat	02514
<i>DIVISION 3 – CONCRETE</i>	
Concrete	03300
<i>DIVISION 4 – MASONRY</i>	
NOT INCLUDED	
<i>DIVISION 5 – METALS</i>	
NOT INCLUDED	
<i>DIVISION 6 – WOODS AND PLASTICS</i>	
NOT INCLUDED	
<i>DIVISION 7 – THERMAL AND MOISTURE PROTECTION</i>	
NOT INCLUDED	
<i>DIVISION 8 – DOORS AND WINDOWS</i>	
NOT INCLUDED	
<i>DIVISION 9 – FINISHES</i>	
NOT INCLUDED	
<i>DIVISION 10 – SPECIALTIES</i>	
NOT INCLUDED	

DIVISION 11 – EQUIPMENT
NOT INCLUDED

DIVISION 12 – FURNISHINGS
NOT INCLUDED

DIVISION 13 – SPECIAL CONSTRUCTION
NOT INCLUDED

DIVISION 15 – MECH
NOT INCLUDED

DIVISION 1 – GENERAL REQUIREMENTS

SECTION 01019

GENERAL SPECIFICATIONS

PART 1 - GENERAL

1.1 GENERAL REQUIREMENTS

Work shall consist of furnishing all labor, tools, materials and equipment necessary and required to construct in place complete all work as indicated on the drawings and as specified herein.

1.2 GENERAL

- A. Examination of Premises: The Contractor shall contact the Engineer and obtain permission before visiting the site.
- B. All lines and grades shall be established by a licensed surveyor , or licensed Civil Engineer, registered in the State of Hawaii. The Contractor shall submit evidence of current and valid registration.
- C. Notices: The Contractor shall notify the Engineer and give at least three (3) working days notice before starting any work.
- D. Disruption of Utility Services: All work related to the temporary disconnection of electrical system shall be pre-arranged with the Engineer so that any disruption of such services will be kept to a minimum. In the event temporary power hook-up is required, the Contractor shall provide the necessary services.
- E. Contractor's Operations
 - 1. The Contractor must employ, insofar as possible, such methods and means of carrying out the work so as not to cause any interruption or interference to the facility's operations. Where the Contractor's operations would result in interruptions which would hamper the operations of the facilities, the Contractor shall rearrange the schedule of work accordingly.
 - 2. The Contractor shall maintain safe passageway to and from the facility for the user agency personnel and the public at all times.
- F. Lead Paint
 - 1. When the project includes paint to be disturbed that was applied prior to 1980, it shall be assumed to contain lead. The Contractor shall inform its employees,

subcontractors, and all other persons engaged in the project that lead containing paints are present in the existing buildings at the job site and to follow the requirements of the Department of Labor and Industrial Relations, Division of Occupational Safety and Health, Title 12, Subtitle 8, Chapter 148, Lead Exposure in Construction, Hawaii Administrative Rules (Chapter 12-148, HAR).

G. Parking Policy for Contractor

1. The Contractor and its employees will not be allowed to park in zones assigned to facility personnel.
2. Areas to be used by the Contractor shall be as designated by the Engineer. Any lawn damaged by the Contractor shall be restored as instructed by the Engineer at no cost to the State.

H. Toilet Accommodations: The Contractor may use the existing toilet facilities if so designated by the Engineer; however, it is the Contractor's responsibility to keep same clean and in a sanitary condition at all times.

I. Protection of Property: The Contractor shall continually maintain adequate protection of all its work from damage and shall protect all property, including but not limited to buildings, equipment, furniture, grounds, vegetation, material, utility systems located at and adjoining the job site. The Contractor shall repair, replace or pay the expense of repair of damages resulting from its operations.

J. Use of Power Driven Equipment: The Contractor is cautioned to take all necessary safety precautions to protect the facility personnel, and the public whenever power driven equipment is used.

K. Safety: The Contractor shall carefully read and strictly comply with the requirements of the Hawaii Occupational Safety and Health Law, Chapter 396, Hawaii Revised Statutes, as amended, is applicable and made a part of the Contract.

L. Clean Up Premises: The Contractor shall clean up and remove from premises all debris accumulated from operations as necessary or as directed. See also Section 7.25 of the General Conditions.

M. Responsibility

1. The State will hold the Contractor liable for all the acts of Subcontractors and shall deal only with the prime Contractor in matters pertaining to other trades employed on the job. The Contractor shall be responsible for coordinating the work of all trades on the job.
2. Should the Contractor discover any discrepancy in the plans or specifications, the Contractor shall immediately notify the Engineer before proceeding any further

with the work, otherwise, the Contractor will be held responsible for any cost involved in correction of work placed due to such discrepancy.

N. Cooperation With Other Contractors: The State reserves the right at any time to contract for or otherwise perform other or additional work within the contract zone limits of this Contract. The Contractor of this project shall, to the extent ordered by the State, conduct its work so as not to interfere with or hinder the progress or completion of the work performed by other contractors.

O. Division of the Work: The Divisions and Sections into which these Specifications are divided shall not be considered an accurate or complete segregation of work by trades. This also applies to all work specified within each Section.

P. Drawings and Specifications

1. The Contractor shall not make alterations in the drawings and specifications. In the event the contractor discovers any errors or discrepancies, the Contractor shall immediately notify the Engineer in accordance with the General Conditions.
2. Where devices, or items, or parts thereof are referred to in the singular, it is intended that such reference shall apply to as many such devices, items or parts as are required to properly complete the work.
3. Specifications and drawings are prepared in abbreviated form and include incomplete sentences. Omission of words or phrases such as "the Contractor shall", "as shown on the drawings", "a", "an", and "the" are intentional. Omitted words and phrases shall be provided by inference to form complete sentences.

Q. Required Submittals

1. Required submittals as specified in the Technical Sections of these specifications include one or more of the following: Shop drawings; color samples; material samples; technical data; schedules of materials; schedules of operations; guarantees; operating and maintenance manuals; and as-built drawings.
2. The Contractor shall make a comprehensive list of the required submittals, by Specification Section, and submit this list to the Engineer within 15 days after notice to proceed.
3. As-Built Drawings: When as-built drawings are required for submittal, the following shall apply:
 - a. As-built drawings, the intent of which is to record the actual in-place construction so that any future renovations or tie-ins can be anticipated accurately, shall be required.

- b. All deviations from alignments, elevations and dimensions which are stipulated on the plans shall be recorded in red on the as-built drawings.
- c. The following procedure shall be followed:
 - 1) Immediately after these changes are constructed in place, the Contractor shall record them on the field office plans.
 - 2) Within two weeks after final inspection of the project, the Contractor shall transfer the changes marked on the field office plans onto a clean copy of plans using a red pencil. Any deletions shall be so noted and redrawn as necessary. The Contractor shall stamp or mark the tracings "AS-BUILT", and also sign and date each drawing so marked.
 - 3) The Contractor shall submit the as-built drawings to the Engineer for review and approval. After the Engineer approves the as-built drawings, the Contractor shall submit an electronic copy in Adobe PDF format on CD ROM.
 - 4) Any as-built drawing which the Engineer determines does not accurately record the deviation shall be corrected by the State, and the Contractor shall be charged for the services.

END OF SECTION

SECTION 01090

STANDARD REFERENCES

PART 1 - GENERAL

Wherever used in the project, the following abbreviations will have the meanings listed:

<u>Abbreviation</u>	<u>Company</u>
AA	Aluminum Association Incorporated 818 Connecticut Avenue, N.W. Washington, D.C. 20006
AASHTO	American Association of State Highway and Transportation Officials 444 North Capitol Street, N.W., Suite 225 Washington, D.C. 20001
ACI	American Concrete Institute P.O. Box 19150 Detroit, MI
AEIC	Association of Edison Illuminating Companies 51 East 42nd Street New York, NY 10017
AFBMA	Anti-Friction Bearing Manufacturer's Association 60 East 42nd Street New York, NY 10017
AGA	American Gas Association 8501 East Pleasant Valley Road Cleveland, OH 44131
AGMA	American Gear Manufacturer's Association 1330 Massachusetts Avenue, N.W. Washington, D.C.
AISC	American Institute of Steel Construction 101 Park Avenue New York, NY 10017
AISI	American Iron and Steel Institute 1000 16th Street, N.W. Washington, D.C. 20036

<u>Abbreviation</u>	<u>Company</u>
AITC	American Institute of Timber Construction 333 West Hampden Avenue Englewood, CO 80110
AMCA	Air Moving and Conditioning Association, Inc. 30 West University Drive Arlington Heights, IL 60004
ANSI	American National Standards Institute, Inc. 1430 Broadway New York, NY 10018
APA	American Plywood Association 1119 A Street Tacoma, WA 98401
API	American Petroleum Institute 1801 K Street N.W. Washington, DC 20006
ARI	Air-Conditioning and Refrigeration Institute 1814 North Fort Myer Drive Arlington, VA 22209
ASCE	American Society of Civil Engineers 345 East 47th Street New York, NY 10017
ASCII	American Standard Code for Information Interchange United States of America Standards Institute 1430 Broadway New York, NY 10018
ASE Code	American Standard Safety Code for Elevators, Dumbwaiter and Escalators American National Standards Institute 1430 Broadway New York, NY 10018
ASHRAE	American Society of Heating, Refrigeration and Air Conditioning Engineers United Engineering Center 345 East 47th Street New York, NY 10017

<u>Abbreviation</u>	<u>Company</u>
ASME	American Society of Mechanical Engineers 345 East 47th Street New York, NY 10017
ASTM	American Society for Testing and Materials 1916 Race Street Philadelphia, PA 19103
AWPA	American Wood Preservers Association 1625 Eye Street Washington, DC 20006
AWS	American Welding Society 2501 N.W. 7th Street Miami, FL 33125
AWWA	American Water Works Association 6666 West Quincy Avenue Denver, CO 80235
CBM	Certified Ballast Manufacturers 2120 Keith Building Cleveland, OH 44115
CMAA	Crane Manufacturers Association of America, Inc. (Formerly called: Overhead Electrical Crane Institute - OECI) 1326 Freeport Road Pittsburgh, PA 15238
CRSI	Concrete Reinforcing Steel Institute 180 North La Salle Street Chicago, IL 60601
CSA	Canadian Standards Association 178 Rexdale Boulevard Rexdale, Ontario, M9W 1R3, Canada
DEMA	Diesel Engine Manufacturer's Association 122 East 42nd Street New York, NY 10017

<u>Abbreviation</u>	<u>Company</u>
DIS	Division of Industrial Safety California Department of Industrial Relations 2422 Arden Way Sacramento, CA 95825
EI	Edison Electric Institute 90 Park Avenue New York, NY 10016
EIA	Electronic Industries Association 2001 Eye Street N.W. Washington, DC 20006
EJMA	Expansion Joint Manufacturer's Association 331 Madison Avenue New York, NY 10017
ESO	Electrical Safety Orders, California Administrative Code, Title 8, Chap. 4, Subarticle 5 Office of Procurement, Publications Section P.O. Box 20191 8141 Elder Creek Road Sacramento, CA 95820
FEDSPEC	Federal Specifications General Services Administration Specification and Consumer Information Distribution Branch Washington Navy Yard, Bldg. 197 Washington, DC 20407
FEDSTDS	Federal Standards (see FEDSPECS)
FM	Factory Mutual Research 1151 Boston-Providence Turnpike Norwood, MA 02062
HEI	Heat Exchange Institute 122 East 42nd Street New York, NY 10017

<u>Abbreviation</u>	<u>Company</u>
HI	Hydraulic Institute 1230 Keith Building Cleveland, OH 44115
IAPMO	International Association of Plumbing and Mechanical Officials 5032 Alhambra Avenue Los Angeles, CA 90032
ICBO	International Conference of Building Officials 5360 South Workman Mill Road Whittier, CA 90601
ICEA	Insulated Cable Engineers Association P.O. Box P South Yarmouth, MA 02664
IEEE	Institute of Electrical and Electronics Engineers, Inc. 345 East 47th Street New York, NY 10017
IES	Illuminating Engineering Society C/O United Engineering Center 345 East 47th Street New York, NY 10017
ISA	Instrument Society of America 400 Stanwix Street Pittsburgh, PA 15222
JIC	Joint Industrial Council 7901 Westpark Drive McLean, VA 22101
MILSPEC	Military Specifications Naval Publications and Forms Center 5801 Tabor Avenue Philadelphia, PA 19120
MSS	Manufacturers Standardization Society of the Valve and Fittings Industry, Inc. 127 Park Street, N.E. Vienna, VA 22180

<u>Abbreviation</u>	<u>Company</u>
NAAMM	National Association of Architectural Metal Manufacturers 100 South Marion Street Oak Park, IL 60302
NACE	National Association of Corrosion Engineers P.O. Box 986 Katy, TX 77450
NEC	National Electric Code National Fire Protection Association 470 Atlantic Avenue Boston, MA 02210
NEMA	National Electrical Manufacturer's Association 155 East 44th Street New York, NY 10017
NESC	National Electric Safety Code American National Standards Institute 1430 Broadway New York, NY 10018
NFPA	National Forest Products Association (Formerly called: National Lumber Manufacturer's Association) 1619 Massachusetts Avenue, N.W. Washington, DC 20036
OSHA	Occupational Safety and Health Act U.S. Department of Labor San Francisco Regional Office 450 Golden Gate Avenue, Box 36017 San Francisco, CA 94102
PPIC	The Plumbing & Piping Industry Council, Inc. Suite 402 510 Shatto Place Los Angeles, CA 90020
SAE	Society of Automotive Engineers 2 Pennsylvania Street New York, NY 10001

<u>Abbreviation</u>	<u>Company</u>
SAMA	Scientific Apparatus Makers Association One Thomas Circle Washington, DC 20005
SBCC	Southern Building Code Congress 1116 Brown-Marx Building Birmingham, AL 35203
SMACNA	Sheet Metal and Air Conditioning Contractors National Association, Inc. 8224 Old Courthouse Road Tysons Corner Vienna, VA 22180
SSPWC	Standard Specifications for Public Works Construction Building News, Inc. 3055 Overland Avenue Los Angeles, CA 90034
TEMA	Tubular Exchanger Manufacturer's Association 331 Madison Avenue New York, NY 10017
UBC	Uniform Building Code Published by ICBO
UL	Underwriters Laboratories Inc. 207 East Ohio Street Chicago, IL 60611
UMC	Uniform Mechanical Code Published by ICBO
UPC	Uniform Plumbing Code Published by IAPMO
USBR	Bureau of Reclamation U.S. Department of Interior Engineering and Research Center Denver Federal Center, Building 67 Denver, CO 80225
WWPA	Western Wood Products Association (Formerly called: West Coast Lumberman's Association - WCLA) Yeon Building Portland, CA 97204

PART 2 - PRODUCTS (NOT USED)

PART 3 - EXECUTION (NOT USED)

- END OF SECTION -

SECTION 01100

ARCHAEOLOGICAL PROTECTION

PART 1 - GENERAL

- 1.1 This section covers the requirements for the protection and preservation of historical sites and values.

PART 2 - PRODUCTS (NOT USED)

PART 3 - EXECUTION

- 3.1 **CONSTRUCTION METHOD:** Representatives of the State will from time to time examine the area as work proceeds. If historical values are noted, the State may order a halt to the work in the vicinity of the historical values until the State can examine further. The Contractor shall notify the State if he finds anything he suspects to be of historic significance and shall discontinue further work in the vicinity of the find until the State can examine the area. In either case, further work in the vicinity of such historical or suspected historical values may proceed only upon approval by the State. Such approval can be normally expected within one week and shall in no case require more than one month.

END OF SECTION

SECTION 01300

SUBMITTALS

PART 1 - GENERAL

1.1 SUBMITTALS

A. Shop drawings shall be required for:

1. Division 16 - Electrical Work.
2. Any others as called for in the plans, specifications or by the Engineer.

B. Other required submittals shall include:

1. Piping Layout.
2. Manufacturer's Data.
3. Certificates of Warranty.
4. Any others as called for in the plans, specifications, or by the Engineer.

1.2 BIDDER'S SPECIAL RESPONSIBILITY FOR COORDINATING CONTRACTUAL WORK AND SUBMITTALS:

A. The Contractor is responsible for the coordination of all contractual work and submittals.

B. The Contractor shall have a rubber stamp made up in the following format:

CONTRACTOR NAME

PROJECT: _____

JOB NO: _____

THIS SUBMITTAL HAS BEEN CHECKED BY THIS GENERAL CONTRACTOR. IT IS CERTIFIED CORRECT, COMPLETE, AND IN COMPLIANCE WITH CONTRACT DRAWINGS AND SPECIFICATIONS. ALL AFFECTED CONTRACTORS AND SUPPLIERS ARE AWARE OF, AND WILL INTEGRATE THIS SUBMITTAL INTO THEIR OWN WORK.

DATE RECEIVED _____

SPECIFICATION SECTION _____
SPECIFICATION PARAGRAPH _____
DRAWING NUMBER _____
SUBCONTRACTOR NAME _____
SUPPLIER NAME _____
MANUFACTURER NAME _____

CERTIFIED BY: _____

- C. This stamp, "filled in", should appear on the title sheet of each shop drawing, on a cover sheet of submittals in an 8-1/2" x 11" format, or on one face of a cardstock tag (min. 3" x 6") tied to each sample. The tag on the samples should state what the sample is so that, if the tag is accidentally separated from the sample, it can be matched up again. The back of this tag will be used by the Engineer for his receipt, review, and log stamp and for any comments that relate to the sample.
- D. All submittals for material, equipment, and shop drawings listed in the contract documents, including dimensioned plumbing shop drawings, shall be required and shall be reviewed by the Engineer, prior to any ordering of materials and equipment.
- E. Unless otherwise noted, the Contractor shall submit to the Engineer for his review eight copies of all shop drawings, piping layout, and/or catalog cuts for fabricated items and manufactured items (including mechanical and electrical equipment) required for the construction. Drawings shall be submitted in sufficient time to allow the Engineer not less than twenty regular working days for examining the drawings.
- F. The drawing shall be accurate, distinct, and complete and shall contain all required information, including satisfactory identification of items, units and assemblies in relation to the contract drawings and specifications.
- G. Unless otherwise approved by the Engineer, shop drawings shall be submitted only by the Contractor, who shall indicate by a signed stamp on the drawings or other approved means that the Contractor has checked the shop drawings and that the work or equipment shown is in accordance with contract requirements and has been checked for dimensions and relationship with work of all other trades involved. All deviations from the plans and specifications shall be listed. The practice of submitting incomplete or unchecked shop drawings for the Engineer to correct or finish will not be acceptable, and shop drawings which, in the opinion of the Engineer, clearly indicate that they have not been checked by the Contractor will be considered as not complying with the intent of the contract documents and will be returned to the Contractor for resubmission in the proper form.
- H. When the shop drawings have been reviewed by the Engineer, two sets of submittals will be returned to the Contractor appropriately stamped. If major changes or corrections are necessary, the drawing may be rejected and one set will be returned to the Contractor with such changes or corrections indicated, and the Contractor shall correct and resubmit eight copies of the drawings, unless otherwise directed by the Engineer. No changes

shall be made by the Contractor to the resubmitted shop drawings other than those changes indicated by the Engineer. The resubmittal shall be so indicated on the shop drawing.

- I. The review of such drawings and catalog cuts by the Engineer shall not relieve the Contractor from responsibility for correctness of the dimensions, fabrication details, and space requirements or for deviations from the contract drawings and specifications, unless the Contractor has called attention to such deviations, in writing, by a letter accompanying the drawings and the Engineer approved the change or deviations, in writing, at the time of submission; nor shall review by the Engineer relieve the Contractor from the responsibility for errors in the shop drawings. When the Contractor does call such deviations to the attention of the Engineer, he shall state in his letter whether or not such deviations involve any deduction or extra cost adjustment.
- J. The approval of the above drawings, lists, prints, specifications, or other data shall in no way release the Contractor from his responsibility for the proper fulfillment of the requirements of this contract nor for fulfilling the purpose of the installation nor from his liability to replace the same should it prove defective or fail to meet the specified requirements.

PART 2 - PRODUCTS (NOT USED)

PART 3 - EXECUTION (NOT USED)

END OF SECTION

SECTION 01505

MOBILIZATION AND DEMOBILIZATION

PART 1 - GENERAL

1.1 GENERAL REQUIREMENTS

A. Description: This section covers the requirements for mobilization and demobilization.

1.2 MOBILIZATION: Mobilization shall consist of the transporting, assembling, constructing, installing, and making ready for use at the job site, all the equipment, machinery, structures, utilities, materials, labor, and incidentals necessary to do the work covered by this contract.

1.3 DEMOBILIZATION: Demobilization shall consist of the dismantling and removal of the above-mentioned equipment, machinery, structures, utilities, materials, and incidentals, and the cleaning up of the site.

PART 2 - PRODUCTS (NOT USED)

PART 3 - EXECUTION

3.1 GUIDELINES: If the Contractor utilizes private lands other than the sites provided by the Department for mobilization purposes, the provisions of this section shall apply, and the mobilization and demobilization work on said private lands shall be in accordance with the agreement between the Contractor and the land owner.

Any and all additional mobilization or demobilization costs in excess of the maximum amounts specified in the Proposal shall be included in the appropriate unit prices bid in the Proposal. The Contractor shall not receive any compensation for mobilization and demobilization in addition to those specified in the Proposal.

All equipment, machinery, buildings, utilities and incidentals mobilized and demobilized under this section shall remain the property of the Contractor.

END OF SECTION

SECTION 01530

BARRICADES

PART 1 - GENERAL

1.1 GENERAL REQUIREMENTS

- A. Description. This work shall consist of furnishing, installing and maintaining barricades in accordance with the requirements of the contract.

Barricade application shall be provided for in the latest edition of the FHWA publication, Manual on Uniform Traffic Control Devices for Streets and Highways (MUTCD), and as amended.

PART 2 - PRODUCTS

2.1 MATERIALS

- A. Lumber: Lumber for rails, frames and braces shall be dry, sound, undamaged, well seasoned, and free from any defect which may impair their strength and durability.
- B. Hardware: Nails shall be galvanized wire nails. As many and as large a size as is practicable shall be used.
- C. Paints: Paints shall be exterior enamel paint of the best grade or first line as made by approved manufacturers.
- D. Sheet Reflecting Material: Sheet reflecting material shall conform to the applicable requirements of Subsection 712.20(C) of the "Standard Specifications for Road and Bridge Construction".
- E. Alternate Designs: Alternate barricade designs such as plastic molded barricades may be used subject to the Engineer's approval. The Contractor shall submit shop drawings or catalog cuts for approval.

PART 3 - EXECUTION

3.1 CONSTRUCTION REQUIREMENTS

- A. General: Barricades shall be constructed in a first class, workmanlike manner in accordance with details shown on the plans and as specified herein.

Barricades shall be in good condition and approved by the Engineer for use within the project limits. Barricade application and installation shall be as shown on the plans and as directed by the Engineer in accordance with the guidelines provided in the latest edition of

the FHWA publication, Manual on Uniform Traffic Control Devices for Streets and Highways (MUTCD), and any amendments or revisions thereof as may be made from time to time.

Sand bags or other approved weights shall be provided where required or as directed by the Engineer. Sand bags or other approved weights shall not be placed on any striped barricade rail.

Steady burn and/or flashing lamps shall be required on selected barricades used during hours of darkness. Locations shall be as shown on the plans and as directed by the Engineer. Lamps shall be attached on the barricade ends closest to the traveled way and shall be visible to the motorist.

Barricades furnished and paid for as provided for as provided herein may be used for temporary detours, construction phasing, or other temporary traffic control work.

Barricades furnished and paid for use in temporary detours or construction phasing may be used for permanent location called for on the plans.

Upon completion of the construction work, barricades shall be left in place, relocated, or removed and disposed of as shown on the plans or as directed by the Engineer. Barricades left in place, or relocated to new permanent locations shall become the property of the State. Barricades directed to be removed and disposed of shall become the property of the Contractor.

- B. Painting: Wooden rails, frames and braces shall be given a prime coat and 2 finish coats of new white exterior enamel paint. Rail faces to be reflectorized may be left unpainted unless otherwise specified or directed.
- C. Reflectorization: Reflectorization of barricade rails shall be done in a first class, workmanlike manner and the attachment of reflective sheeting shall be as shown on the plans, specified herein, or as directed and approved by the Engineer.

Both vertical faces of each barricade rail shall be reflectorized as shown on the plans.

Wooden rails shall be reflectorized with one of the following:

1. Reflective sheeting specified in Subsection 712.20(C)(4) of the "Standard Specifications for Road and Bridge Construction" and backed with a 26 gage galvanized steel sheet, or
2. a hardened aluminum backed reflective sheeting as specified in Subsection 712.20(C)(5) of the "Standard Specifications for Road and Bridge Construction."

D. Color: Rails, frames and braces shall be white.

The front and back faces of barricade rails shall have 6-inch wide alternative colored and white striped sloping downward toward the traveled way at an angle of 45 degrees with the vertical. The colored stripes shall be either orange or red in accordance with the following requirements:

1. Orange and white stripes shall be used in the following conditions:
 - a. Construction work.
 - b. Detours.
 - c. Maintenance work.
2. Red and white stripes shall be used in the following conditions:
 - a. On roadways with no outlet (ie. dead-ends, cul-de-sacs).
 - b. Ramps or lanes closed for operational purposes.
 - c. Permanent or semipermanent closure or termination of a roadway.

E. Maintenance: Barricades shall be kept in good condition throughout their usage during construction until the end of the contract.

F. The Contractor shall repair, repaint, clean or replace the barricades as required and as directed by the Engineer to maintain their effectiveness and appearance.

The Constructor shall immediately replace all lost, stolen or damaged barricades, lamps, sand bags and other approved weights.

Barricades used during construction phasing, temporary detours or other temporary traffic control work shall be cleaned and repaired as necessary, prior to being relocated to a permanent location shown on the plans or as directed.

No extra payment will be made for any repair work, repainting, or cleaning of barricades. The Engineer shall determine the suitable condition of each barricade and shall determine when each barricade shall be repaired, repainted or cleaned.

END OF SECTION

SECTION 01567

POLLUTION CONTROL

PART 1 - GENERAL

1.1 GENERAL REQUIREMENTS

A. Rubbish Disposal

1. No burning of debris and/or waste materials shall be permitted on the project site.
2. No burying of debris and/or waste material except for materials which are specifically indicated elsewhere in these specifications as suitable for backfill shall be permitted on the project site.
3. All unusable debris and waste material shall be hauled away to an appropriate off-site dump area. During loading operations, debris and waste materials shall be watered down to allay dust.
4. No dry sweeping shall be permitted in cleaning rubbish and fines which can become airborne from floors or other paved areas. Vacuuming, wet mopping or wet or damp sweeping is permissible.
5. Enclosed chutes and/or containers shall be used for conveying debris from above to ground floor level.
6. Clean-up shall include the collection of all waste paper and wrapping materials, cans, bottles, construction waste materials and other objectionable materials, and removal as required. Frequency of clean-up shall coincide with rubbish producing events.

B. Dust

1. The Contractor shall prevent dust from becoming airborne at all times including non-working hours, weekends and holidays in conformance with the State Department of Health, Administrative Rules, Title 11, Chapter 60 - Air Pollution Control.
2. The method of dust control and costs shall be the responsibility of the Contractor. Methods of dust control shall include the use of water, chemicals or asphalt over surfaces which may create airborne dust.
3. The Contractor shall be responsible for all damage claims in accordance with Section 7.16 - "Responsibility for Damage Claims" of the GENERAL CONDITIONS.

C. Noise

1. Noise shall be kept within acceptable levels at all times in conformance with the State Department of Health, Administrative Rules, Title 11, Chapter 46 - Community Noise Control for Oahu. The Contractor shall obtain and pay for the Community Noise Permit from the State Department of Health when the construction equipment or other devices emit noise at levels exceeding the allowable limits.
2. All internal combustion engine-powered equipment shall have mufflers to minimize noise and shall be properly maintained to reduce noise to acceptable levels.
3. Pile driving operations shall be confined to the period between 9:00 a.m. and 5:30 p.m., Monday through Friday. Pile driving will not be permitted on weekends and legal State and Federal holidays.
4. Starting-up of construction equipment meeting allowable noise limits shall not be done prior to 6:45 a.m. without prior approval of the Engineer. Equipment exceeding allowable noise levels shall not be started-up prior to 7:00 a.m.

D. Erosion

1. During interim grading operations, the grade shall be maintained so as to preclude any damage to adjoining property from water and eroding soil.
2. Temporary berms, cut-off ditches and other provisions which may be required because of the Contractor's method of operations shall be installed at no cost to the State.
3. Drainage outlets and silting basing shall be constructed and maintained as shown on the plans to minimize erosion and pollution of waterways during construction.

E. Others

1. Wherever trucks and/or vehicles leave the site and enter surrounding paved streets, the Contractor shall prevent any material from being carried onto the pavement. Waste water shall not be discharged into existing streams, waterways, or drainage systems such as gutters and catch basins unless treated to comply with the State Department of Health water pollution regulations.
2. Trucks hauling debris shall be covered as required by PUC Regulation. Trucks hauling fine materials shall be covered.
3. No dumping of waste concrete will be permitted at the job-site.

4. Except for rinsing of the hopper and delivery chute, and for wheel washing where required, concrete trucks shall not be cleaned on the job-site.
5. Except in an emergency, such as a mechanical breakdown, all vehicle fueling and maintenance shall be done in a designated area. A temporary berm shall be constructed around the area when runoff can cause a problem.
6. When spray painting is allowed such spray painting shall be done by the "airless spray" process. Other types of spray painting will not be allowed.

F. Suspension of Work

1. Violations of any of the above requirements or any other pollution control requirements which may be specified in the Technical Specifications herein shall be cause for suspension of the work creating such violation. No additional compensation shall be due the Contractor for remedial measures to correct the offense. Also, no extension of time will be granted for delays caused by such suspensions.
2. If no corrective action is taken by the Contractor within 72 hours after a suspension is ordered by the Engineer, the State reserves the right to take whatever action is necessary to correct the situation and to deduct all costs incurred by the State in taking such action from monies due the Contractor.
3. The Engineer may also suspend any operations which he feels are creating pollution problems although they may not be in violation of the above-mentioned requirements. In this instance, the work shall be done by force account as described in Subsection 4.2b -"Additional Work" of the GENERAL CONDITIONS and paid for in accordance with Subsection 8.4b - "Force - Account Work" therein. The count of elapsed working days to be charged against the contract in this situation shall be computed in accordance with Subsection 7.18 - "Contract Time" of the GENERAL CONDITIONS.

PART 2 - PRODUCTS (NOT USED)

PART 3 - EXECUTION (NOT USED)

END OF SECTION

SECTION 01581

PROJECT SIGN

PART 1 - GENERAL

1.1 GENERAL REQUIREMENTS

Furnish all labor, materials and equipment necessary to construct and install all project sign as specified hereinafter.

1.2 SUBMITTAL

The contractor shall provide the Engineer with six (6) shop drawings of the project sign for review and approval by the Engineer prior to ordering the sign.

1.3 LETTER STYLE

Copy is centered and set in Adobe Type Futura Heavy. If this specific type is not available, Futura Demi Bold may be substituted. Copy should be set and spaced by a professional typesetter and enlarged photographically for photo stencil screen process.

1.4 ART WORK

Constant elements of the sign layout - frame, outline, stripe, and official state information - may be duplicated following drawing measurements, or be reproduced and enlarged photographically using a layout template if provided. The "STATE OF HAWAII" masthead should be reproduced and enlarged as specified, using the artwork provided.

1.5 TITLES

The specific major work of the project under construction is emphasized by using 3-3/4" type, all capitals. Secondary information such as location or buildings uses 2-1/4" type, all capitals. Other related information of lesser importance uses letter heights as indicated on 01581-3, upper / lower case letters.

Design should follow the example on page 01581-3.

PART 2 - PRODUCTS

2.1 MATERIALS

A. LUMBER

1. Panel is 3/4" exterior grade high density overlaid plywood, with resin-bonded surfaces on both sides.
2. 4"x4" sign posts shall be Douglas Fir No. 1 or better.

B. PAINTS & INKS

Screen print inks are matte finish. Paints are satin finish, exterior grade. References to Ameritone Color Key Paint are for color match only.

COLOR:	1.	1BL10A	Bohemian Blue
	2.	2H16P	Softly (White)
	3.	2VR2A	Hot Tango (Red)
	4.	1M52E	Tokay (Gray)

C. CONCRETE

Concrete shall be class B with a 2,500 psi 28-day compressive strength.

PART 3 - EXECUTION

3.1 GENERAL

- A. The Project Sign shall be constructed with new materials as specified above.
- B. The Project sign shall be installed at the location indicated on the drawings or as designated by the Engineer. The project sign shall be erected upon commencement of work.

3.2 MEASUREMENTS AND PAYMENT

The construction of the project sign, including all equipment, labor and material necessary to furnish and install the project sign will be paid for under the "Project Sign" proposal item.

END OF SECTION

Project Sign
01581-2

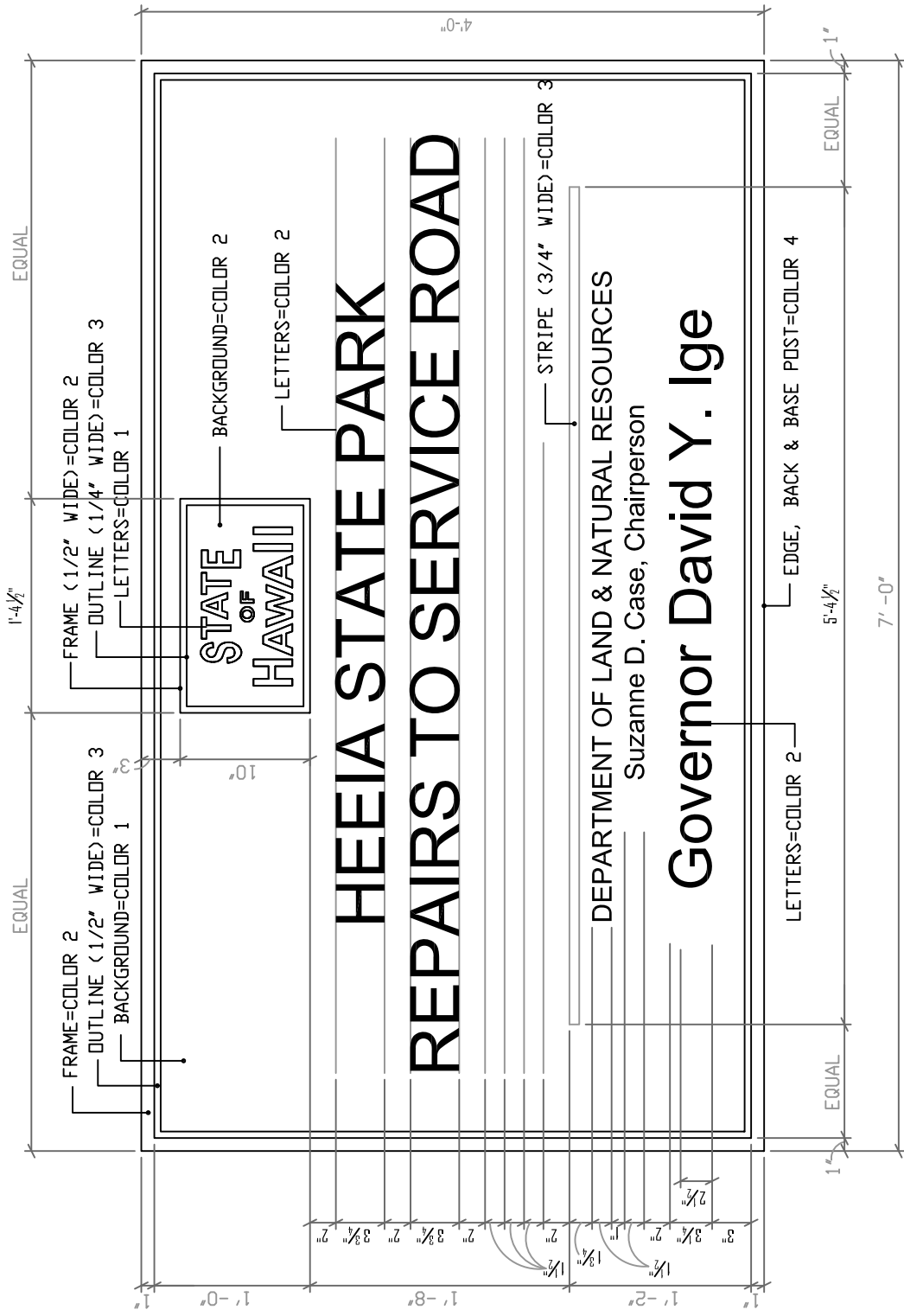

NOTE: Number of signs required 1

Project Sign
01581-3

Job No.

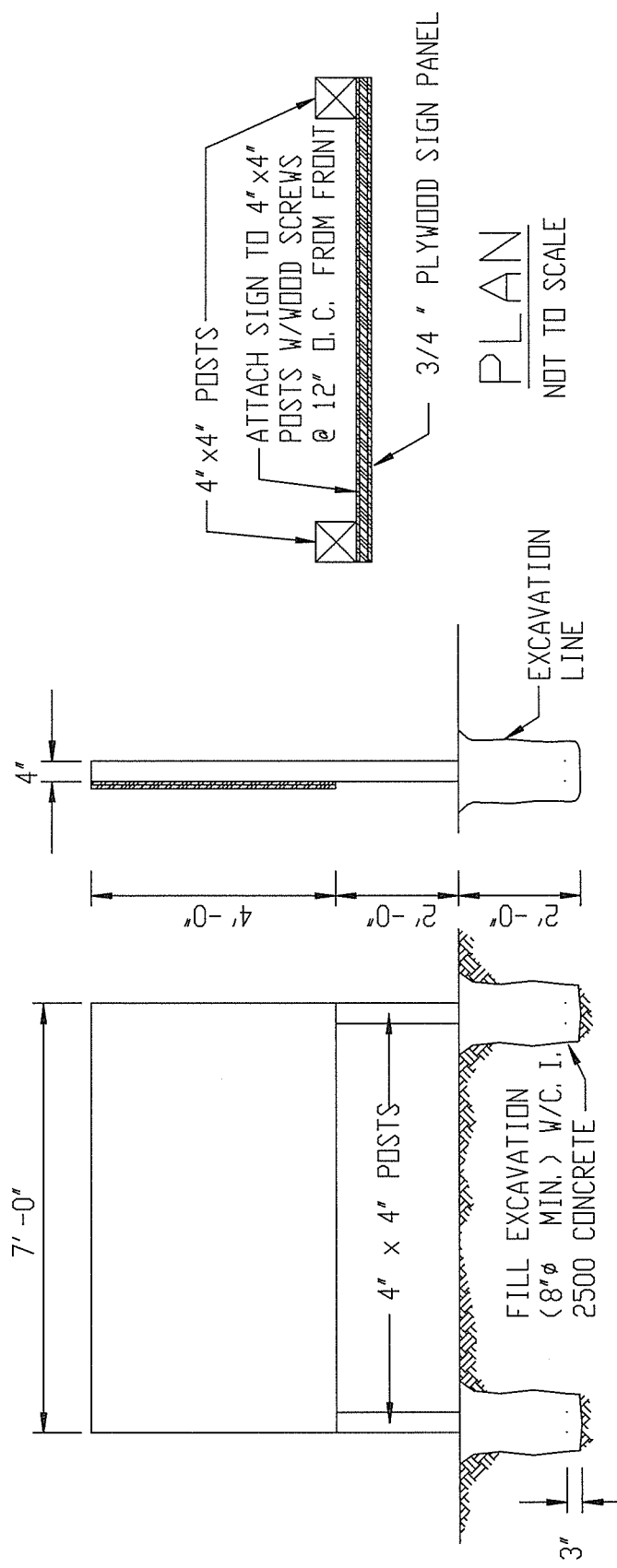

PLAN
NOT TO SCALE

SIDE ELEVATION
NOT TO SCALE

FRONT ELEVATION
NOT TO SCALE

DIVISION 2 – SITEWORK

SECTION 02100

SITE PREPARATION

PART 1 - GENERAL

1.1 GENERAL REQUIREMENTS

The work to be performed under this section shall include clearing the premises of all obstacles and obstructions, the removal of which will be necessary for the proper reception, construction, execution and completion of the other work included in this contract.

1.2 COORDINATION WITH OTHER SECTIONS

- A. Earthwork is specified in Section 02200 - EARTHWORK.

PART 2 - PRODUCTS (NOT USED)

PART 3 - EXECUTION

3.1 GENERAL

- A. Maintenance of Traffic: The Contractor shall conduct operations with minimum interference to streets, driveways, sidewalks, passageways, etc.

When necessary, the Contractor shall provide and erect barriers, etc., with special attention to protection of personnel.

- B. Protection: Throughout the progress of the work protection shall be provided for all property and equipment, and temporary barricades shall be provided as necessary. Work shall be done in accordance with the safety provisions of the Manual of Accident Prevention in Construction, published by the Associated General Contractors of America, and the State of Hawaii's Occupational Safety and Health Standards, Rules and Regulations.
- C. Fires: No burning of fires of any kind will be allowed.
- D. Reference Points: Bench marks, etc., shall be carefully maintained, but if disturbed or destroyed, shall be replaced as directed, at the Contractor's expense.
- E. Disposal: All materials resultant from operations under this Section shall become the property of the Contractor and shall be removed from the site. Loads of materials shall be

trimmed to prevent droppings

3.2 EXISTING UTILITY LINES

- A. The existence of active underground utility lines within the construction area is not definitely known other than those indicated in their approximate locations on the Drawings. Should any unknown line be encountered during excavation, the Contractor shall immediately notify the Engineer of such discovery. The Engineer shall then investigate and issue instructions for the preservation or disposition of the unknown line. Authorization for extra work shall be issued by the Engineer only as he deems necessary.

3.3 CLEARING AND GRUBBING

- A. The Contractor shall clear the premises of all obstacles and obstructions, the removal of which will be necessary for the proper reception, construction, execution and completion of other work included in this contract.
- B. After clearing has been completed, the entire site shall be stripped of the organically contaminated near-surface soils to a minimum depth of 6 inches. Remove trees and roots to a minimum of 3 feet below existing ground level. Remove all large roots in excess of 2 inches in diameter, and backfill and compact the resulting depression. All debris accumulated from this operation shall be completely removed from the premises by the Contractor.
- C. The Contractor shall protect from injury and damage all surrounding trees, plants, etc., and shall leave all in as good as condition as at present. Any damage to existing improvement shall be repaired or replaced by the Contractor to the satisfaction of the Engineer.

3.4 CLEAN UP OF PREMISES

- A. Clean up and remove all debris accumulated from building operations from time-to-time as directed. Upon completion of the construction work and before final acceptance of the contract work, remove all surplus materials, equipment, scaffoldings, etc., and leave entire job site raked clean and neat to the satisfaction of the Engineer.

END OF SECTION

SECTION 02110

CLEARING AND GRUBBING

PART 1 - GENERAL

1.1 GENERAL REQUIREMENTS

This section covers the requirements for clearing and grubbing, within the areas shown on the plan or as directed by the Engineer. The above work shall include the removal and disposal of designated trees outside the clearing limits. Also included is the protection from injury or defacement of trees and other objects designated to remain and treatment or removal of damaged trees.

PART 2 - PRODUCTS (NOT USED)

PART 3 - EXECUTION

3.1 CLEARING AND GRUBBING WORK:

- A. The area to be cleared shall be to the dimensions shown on the plans or one foot beyond toe of fill and top of cut whichever is greater.
- B. All debris, trees, logs, limbs, branches, brush, plants, and other protruding obstructions within the clearing limits shall be removed and disposed of, except the following:
 - 1. Live, sound, and firmly rooted trees with diameter of 4 inches or larger.
 - 2. Live brush, herbaceous plants, and trees between the trailbed and clearing limits that are less than 12 inches in height.
- C. Except as provided above, all limbs and branches more than 1/2 inch in diameter that extend into the cleared area shall be cut flush with the tree trunks or stems or cut at the ground surface.
- D. Felling, cutting, and trimming methods shall not cause bark damage to standing timber. If damage does occur to standing trees, the injured area shall be treated with a coat of tree-surgery asphalt-based paint. Trees with major roots exposed by construction that are rendered unstable shall be felled and disposed of as specified herein.
- E. All stumps within the trailbed shall be removed. Stumps located between the edge of the trailbed and clearing limits that cannot be cut flush with the finished slope, or are not tightly rooted, shall be removed.

- F. All logs, limbs, lopped tops, brush, and grubbed stumps and roots shall be scattered on the downhill side of and outside the clearing limits, with the following exceptions:
1. Limbs, brush, and lopped tops from trees felled on the uphill side of the clearing limits shall be scattered below the trailway, except where the existing sideslope above the trail is less than 20 percent; such material may be scattered above the trail.
 2. Logs may be left on the uphill side of the trail if they are placed so that they will not move into the clearing limits.
- G. Debris from clearing and grubbing operations shall not be placed in streams, water courses or at locations that will impede flow of the natural drainage pattern.

END OF SECTION

SECTION 02200

EARTHWORK

PART 1 - GENERAL

1.1 GENERAL REQUIREMENTS

This section covers the requirements for earthwork.

- A. It shall be the responsibility of the Contractor to examine the project site and determine for himself the existing conditions.
- B. Obvious conditions of the site existing on the date of the bid opening shall be accepted as part of the work, even though they may not be clearly indicated on the drawings and/or described herein or may vary therefrom.
- C. All debris of any kind accumulated from clearing shall be disposed of from the site, and the whole area left clean. The Contractor shall be required to make all necessary arrangements relative to the proposed place of disposal.

1.2 REMOVAL AND REPAIR WORK

A. General

The Contractor shall exercise every precaution to preserve and protect all structures, walkways or utility improvements which are to remain or be relocated. Portions of walkway and pavement which are to remain shall be saw cut neat and true to line. Restore all pavement and curbs upon completion of the work.

1.3 SEQUENCE OF WORK

All sequence of work shall be subject to the approval of the Engineer.

1.4 PROTECTION

- A. Barricade: Erect temporary barricade to prevent people from entering into project area, to the extent as approved by the Engineer. Such barricade shall be as defined in Section 01530 - BARRICADES. The extent of barricades may be adjusted as necessary with the approval of the Engineer. This work shall be accomplished at no extra cost to the State of Hawaii.
- B. Take all precautions and safety measures as required to protect the State of Hawaii free and harmless from liability of any kind. Conduct operations with minimum interference to streets, driveways, sidewalks passages, etc.

- C. Adequate precautions shall be taken before commencing and during the course of the work to ensure the protection of life, limb, and property.
- D. The Contractor shall protect from damage all surrounding structures, trees, plants, grass, walks, pavements, etc. Any damage will be repaired or replaced by the Contractor to the satisfaction of the Engineer at no cost to the State.

1.5 PERMITS

The Contractor shall obtain and pay for necessary permits prior to the commencement of work.

1.6 MAINTAINING TRAFFIC

- A. The Contractor shall conduct operations with minimum interference to streets, driveways, sidewalks, traffic activities, etc.
- B. When necessary, the Contractor shall provide, erect and maintain lights, barriers, etc., as required by traffic and safety regulations with special attention to protection of life.

1.7 CONSTRUCTION LINES, LEVELS AND GRADES

- A. The Contractor shall verify all lines, levels and elevations indicated on the drawings before any clearing, excavation or construction begins. Any discrepancy shall be immediately brought to the attention of the Engineer and any changes shall be made in accordance with his instructions. The Contractor shall not be entitled to extra payment if he fails to report the discrepancies before proceeding with any work whether within the area affected or not.
- B. The laying out of base lines, establishment of grades and staking out the entire work shall be done by a licensed Surveyor or a licensed Civil Engineer, registered in the State of Hawaii. He shall be solely responsible for their accuracy. Erect and maintain substantial batter boards showing construction lines and levels.

1.8 CLEANUP

Clean up and remove all debris accumulated from construction operations from time to time, when as directed by the Engineer. Upon completion of the construction work and before final acceptance of work, remove all surplus materials, equipment, etc. and leave entire jobsite clean and neat.

PART 2 - PRODUCTS

2.1 MATERIALS

- A. Yard Fill: Fill materials shall be soil with expansion value not greater than 3%, free from debris, perishable or combustible materials, sod and stones larger than 6" in maximum dimension. Rock or broken masonry shall be well distributed in earth or other fine material with voids filled and shall be placed within three feet of finished grades.
- B. Structural Fill: New structural fill below interior and exterior concrete slabs or paving, with allowance for depth of cushion fill, shall be select borrow material. This material shall be granular with an expansion value not greater than 3% non-adobe and with a plasticity index less than ten. Decayed rubbish, debris, or rocks greater than 3" in diameter shall not be allowed as fill material. Certificate of compliance shall be submitted to the Engineer for approval prior to filling.
- C. Topsoil: Imported, fertile, friable soil of loamy character having normal amounts of natural humus, free from subsoil, clay, refuse roots, weeds, noxious seeds, nematodes or other deleterious matter, and free from toxic amounts of either acid or alkaline elements and capable of sustaining healthy plant life. Stones and earth lumps shall not be greater than one inch in largest dimension. Red humic latosol soils, or types known as "Palolo clay" or Lualualei clay" are unacceptable. Topsoil is subject to approval by Engineer.

PART 3 - EXECUTION

3.1 EXCAVATION

- A. Protective Measures
 - 1. All excavation shall be protected and guarded against danger to life, limb and property.
 - 2. Shoring, cribbing and logging, as required to safely preserve the excavations and earth banks, free from damages resulting from the work shall be provided and installed by the Contractor.
 - 3. All excavations shall be kept free from standing water. The Contractor shall do all pumping and draining that may be necessary to remove water to the extent required in carrying on the work. Grading shall be controlled so that the ground surface is properly sloped to prevent water run-off into structural foundations and open trenching excavations.
 - 4. The underground utilities lines traversing the construction area known to exist by the designer are indicated on the plans.. Should any be encountered during

excavation, the Contractor shall not disconnect same without authorization from the Engineer but shall inform the latter immediately of each discovery. The Engineer shall investigate and issue proper authorization for procedure.

B. General

1. Excavation shall be done to the lines and grades indicated. Concrete slabs, concrete curbs, asphaltic concrete pavement, etc., not indicated to remain shall be removed or broken up into pieces of sizes permitted in other paragraphs of this section. When incorporated in fill, broken up pieces shall be well mixed with finer materials filling all spaces between the pieces.
2. Excavation for footings, foundation, etc., shall have level beds on unfilled, undisturbed, firm bearing, with stepped level where necessary. Small soft spots shall be compacted to unyielding firmness.

If soil conditions are suitable and approved, footing cuts may be made to exact size of footing.

3. Structural excavations carried below specified level shall be filled with concrete to the proper level at the expense of the Contractor.
4. Excavated materials declared unusable by Engineer shall be removed from the site at the Contractor's expense.

3.2 BACKFILL

A. Yard Area

1. Yard fill where no concrete slab occurs shall be in 6" layers (compacted thickness) compacted to 90% of maximum density as determined by ASTM Test, Method D-1557.
2. The areas not covered by asphalt paving or concrete slab shall be graded to conform to finish contours, with allowance for depth of topsoil. Rough grading shall prevent the drainage of water into construction areas.

B. Structural Fill

1. In advance of preparing the subgrade or depositing a specified layer of material, existing material within the area where such materials is to be placed, which in the opinion of the Engineer is unsuitable as a subgrade foundation, shall be removed and the resulting space refilled with approved material and compacted.
2. Backfilling shall progress so that excessive unbalanced load is not introduced against any structure.

3. New structural fill material shall be placed in layers not to exceed 6" per compacted layer and compacted to a compaction of 90% as determined by ASTM Test, Method D-1557.
4. Materials and compaction of all yard and structural fill shall be tested by an independent testing agency approved by the Engineer and all after-compaction test results submitted to the Engineer for approval. All cost of testing shall be borne by the Contractor. Testing shall be made throughout the area for each 6" compacted layer as directed by the Engineer. All test results must be approved before proceeding with placing of topsoil, cushion fill or base course.
5. In the event insufficient amount of structural fill or yard fill is derived from earthwork operations, import the necessary materials without any additional cost to the State. Such imported material shall meet the requirements as specified for each category of materials.
6. The ground shall be scarified 6" below existing grade and recompact to 90% compaction. Fill shall conform to structural fill.
7. Under interior and exterior slabs the cushion fill as specified shall be compacted to a level surface to 95% compaction as determined by modified ASTM Test Method, D-1557.

C. Grading

1. Rough Grading: The areas not covered by asphalt paving or concrete slab up to the contract zone limit shall be graded to topsoil. Contractor shall take the necessary precautions to prevent the drainage of water into construction area.
2. Finish Grading: Outdoor areas not covered by buildings shall be graded to finish grade and contours with allowance for a 4" layer of topsoil as required. Grading shall conform with the ordinances of the applicable County issuing the Grading Permit and as amended. Areas to be topsoiled to 85% of maximum density before placing topsoil. Topsoil shall be spread evenly, compacted lightly and raked to a uniform place at required contours and grades.

3.3 GRASSING

- A. Replant graded and damaged areas with grass similar to adjoining area.

- B. Grass shall be maintained. Maintenance shall include watering, weeding, mowing, repairing, regrassing and protection, and be performed until the entire project is accepted but in any event for a period not less than 60 days after planting of grass. At the time of acceptance, the grass shall have been well-established and shall be give a final weeding and a final mowing to a height of 1 inch. If the maintenance period has expired before acceptance of the entire project, the Contractor shall continue to maintain the grass until acceptance of the entire project. If the maintenance period should extend beyond acceptance of the entire project, the Contractor shall continue to maintain the grass until the end of the specified period of time required for maintenance.

END OF SECTION

SECTION 02225

TRENCHING, BACKFILLING, AND COMPACTING

PART 1 - GENERAL

1.1 GENERAL REQUIREMENTS

This section covers the requirements for trenching, backfilling, and compacting.

- A. Work included: Trench, backfill, and compact as specified herein and as needed for installation of underground utilities associated with the Work.
- B. Related Work:
 - 1. Documents affecting work of this Section include, but are not necessarily limited to, General Conditions, Supplementary Conditions, and Sections in Division 1 of these Specifications.

1.2 QUALITY ASSURANCE

- A. Use adequate numbers of skilled workers who are thoroughly trained and experienced in the necessary crafts and who are completely familiar with the specified requirements and the methods needed for proper performance of the work of this Section.
- B. Use equipment adequate in size, capacity, and numbers to accomplish the work in a timely manner.
- C. In addition to complying with requirements of governmental agencies having jurisdiction, comply with the directions of the Engineer.
- D. Compaction requirements are defined by American Society for Testing and Materials (ASTM) publication D-1557 "Moisture-Density Relations of Soils and Soil-Aggregate Mixtures using 10-lb Rammer and 18-inch Drop."

1.3 SUBMITTALS

- A. Shoring and sheeting plan: Describe materials of shoring system to be used. Indicate whether or not components will remain after filling or backfilling. Provide plans, sketches, or details along with calculations by a professional engineer registered in Hawaii. Indicate sequence and method of installation and removal.
- B. Dewatering plan: Describe methods for removing collected water from open trenches and diverting surface water or piped flow away from work area. Describe equipment and procedures for installing and operating the dewatering system indicate.

1.4 PERMITS

- A. Obtain necessary permits required from applicable agencies. All permit fees will be considered incidental to the work and a separate payment shall not be made.

PART 2 - PRODUCTS

2.1 BACKFILL MATERIALS

- A. **Select Material:** Backfill from the bottom of the trench to one foot above the top of the pipe shall be select material. Sand, graded crushed rock (commonly known as "rock sand") or excavated granular or sandy material shall be used for select material provided that all rocks or lumps of material over one inch in its longest dimension have been removed. Select material shall be free from salt, ashes, refuse, organic material or other material which, in the opinion of the Engineer, is unsuitable.

All material to be used as select material backfill shall be approved by the Engineer. If in the opinion of the Engineer the excavated material does not meet the grading requirements of select material, the Contractor shall be required to screen the material prior to its use as select material backfill.

- B. **Ordinary Material:** Material used in the upper portion of the backfill from one foot above the top of the pipe to the surface of the ground or subgrade of the road shall not contain stone, rock or other material larger than six inches in its longest dimensions. No wood, vegetable matter or other material which, in the opinion of the Engineer, is unsuitable, shall be included in the backfill. No "adobe" or other materials determined to be deleterious by the Engineer shall be included in the backfill.
- C. The Contractor shall obtain the approval of the Engineer of all backfill material.

2.2 OTHER MATERIALS

- A. Provide other materials, not specifically described but required for a complete and proper installation, as selected by the Contractor subject to the approval of the Engineer.

PART 3 - EXECUTION

3.1 SURFACE CONDITIONS

- A. Examine the areas and conditions under which work of this Section will be performed. Correct conditions detrimental to timely and proper completion of the Work. Do not proceed until unsatisfactory conditions are corrected.

3.2 FINISH ELEVATIONS AND LINES

- A. All material excavated from trenches shall be considered unclassified, whether consisting of earth, lava, soft rock, decomposed rock, solid rock, boulders, or coral. The trench shall be so dug that the pipe can be properly installed to the alignment and grade specified. Excavation shall commence at the point directed by the Engineer and shall be carried on in an orderly manner. No trench shall be opened more than 500 feet in advance of the installed pipe without the approval of the Engineer. No jumps or spaces will be permitted unless approved by the Engineer. Before proceeding with any excavation under asphaltic concrete and concrete pavements, the Contractor shall cut the edges of the excavation with a power saw to insure a neat cut along the pavement.
- B. Trench Widths:
 - 1. The widths of trenches for all pipes and appurtenances shall be as shown on the Drawings.
 - 2. Increases in widths over those shown due to sheeting, bracing, or other necessities of construction, may be made by the Contractor with the approval of the Engineer but no additional compensation will be allowed for such extra width.
 - 3. Bell holes shall be provided at each joint to permit the jointing of pipes to be made properly.
- C. Trench Depths:
 - 1. In general, trench depths for all pipes and appurtenances shall be as shown on the Drawings.
 - 2. Where necessary, the Engineer reserves the right to raise or lower the grades or to change alignments from those shown on the Drawings.
- D. Excavation Below Grades:
 - 1. Any part of the trench excavated below grade by the Contractor shall be corrected with select material, thoroughly compacted in place at no cost to the State.

3.3 PROCEDURES

- A. Utilities:
 - 1. All excavated areas shall be toned prior to excavation.
 - 2. Unless shown to be removed, protect lines shown on the drawings or otherwise made known to the Contractor prior to trenching. If damaged, repair or replace at no additional cost to the State.

3. If active utility lines are encountered, and are not shown on the Drawings or otherwise made known to the Contractor, promptly take necessary steps to assure that service is not interrupted.
 4. If service is interrupted as a result of work under this Section, immediately restore service by repairing the damaged utility at no additional cost to the State.
 5. Expose existing utilities to confirm clearances as initial trenching work. If existing utilities are found to interfere with the permanent facilities being constructed under this Section, immediately notify the Engineer and secure his instructions.
 6. Do not proceed with permanent relocation of utilities until written instructions are received from the Engineer.
- B. Protection of persons and property:
1. Barricade open holes and depressions occurring as part of the Work, and post warning lights on property adjacent to or with public access.
 2. Operate warning lights during hours from dusk to dawn each day and as otherwise required.
 3. Protect structures, utilities, sidewalks, pavements, and other facilities from damage caused by settlement, lateral movement, washout, and other hazards created by operations under this Section.
- C. Blasting:
1. Blasting shall not be permitted.
- D. Dewatering:
1. Remove water by pumping or other methods to prevent the softening of surfaces exposed by excavation, prevent hydrostatic uplift, and provide a stable trench condition for installation of the utility. Use screens and gravel packs or other filtering systems on the dewatering devices to prevent the removal of fines from soil.
 2. Dispose water at an approved location by pumps, drains, and other approved methods.
- E. During the period of construction, the Contractor shall protect the public against mud, dust and similar nuisances and shall take steps to abate such nuisances.

- F. Convenient access to buildings along the line of work shall be maintained and temporary approaches shall be provided and kept in order. Temporary bridges for pedestrian traffic shall have handrails securely fastened to them. Handrails shall be free from any projecting nails, splinters, and rough edges.
- G. Storing of excavated material alongside the trench shall be done in such a manner as not to obstruct traffic. Whenever, in the opinion of the Engineer, proper storage of excavated material cannot be made alongside the pipe trench, the material shall be hauled away from the work site. If the excavated material meets the requirements for backfill material and proper storage cannot be made alongside the pipe trench, the material shall be stockpiled at convenient locations for later use in backfill.
- H. Surplus Material:
 - 1. Unless otherwise specified in the Plans or Specifications, or ordered by the Engineer, surplus excavated material shall become the Contractor's property and shall be removed from the work site and disposed of at no cost to the State.

3.4 TRENCHING

- A. Comply with pertinent provisions of applicable "Soils Report" as provided for the project and the provisions of this Section.
- B. Provide sheeting and shoring necessary for protection of the Work, undermining of existing facilities and for the safety of personnel.
 - 1. Prior to backfilling, remove all sheeting.
 - 2. Do not permit sheeting to remain in the trenches except when, in the opinion of the Engineer, field conditions or the type of sheeting or methods of construction such as use of concrete bedding are such as to make removal of sheeting impracticable. In such cases, the Engineer may permit portions of sheeting to be cut off and remain in the trench.
- C. Excavation:
 - 1. Short sections of a trench may be tunneled if, in the opinion of the Engineer, the conduit can be installed safely and backfill can be compacted properly into such tunnel.
 - 2. Where it becomes necessary to excavate beyond the limits of normal excavation lines in order to remove boulders or other interfering objects, backfill the voids remaining after removal of the objects at no additional cost to the State, as directed by the Engineer.

3. When the void is below the subgrade for the utility bedding, use select materials and compact to the relative density directed by the Engineer, but in no case to a relative density less than 90%.
4. When the void is in the side of the utility trench or open cut, use suitable earth or sand compacted or consolidated as approved by the Engineer, but in no case to a relative density less than 80%.
5. Excavating for appurtenances:
 - a. Excavate for manholes and similar structures to a distance sufficient to leave at least 12" clear between outer surfaces and the embankment or shoring that may be used to hold and protect the banks.
 - b. Overdepth excavation beyond such appurtenances that has not been directed will be considered unauthorized. Fill with sand, gravel, or lean concrete as directed by the Engineer, and at no additional cost to the State.

D. Depressions:

1. Dig bell holes and depressions for joints after the trench has been graded. Provide uniform bearing for the pipe on prepared bottom of the trench.
2. Except where rock is encountered, do not excavate below the depth indicated or specified.
3. Where rock is encountered, excavate rock to a minimum overdepth of 4" below the trench depth indicated or specified.

E. Where trenching occurs in existing lawns, remove turf in sections and keep damp. Replace turf upon completion of the backfilling.

F. Cover:

1. Provide a minimum cover over the top of the pipe as indicated on the drawings.
2. Where the minimum cover is not provided, jacket the pipes in concrete as indicated. Provide concrete with a minimum 28 day compressive strength of 2500 psi.

3.5 BEDDING

A. Provide bedding as indicated on the Drawings.

3.6 BACKFILLING

A. General

1. All backfill material shall be placed in the trench by hand or by approved mechanical methods. The compaction of backfill material shall be done by tamping with hand tools or approved pneumatic tampers, by using vibratory compactors, by puddling if the backfill material can be suitably drained, or by any combination of the three. The method of compaction shall be approved by the Engineer and all compaction shall be done to the satisfaction of the Engineer. All cost of testing shall be borne by the Contractor.
2. When removal of unsuitable excavated material creates a shortage of backfill material, the Contractor shall, at no cost to the State, furnish material as specified in this section in the amount required to complete the backfill.
3. When backfill material is delivered by trucks, the material shall not be dumped directly into the trench but the fall of the material shall be broken at the edge of the trench. The backfill material shall then be deposited by hand or by approved mechanical methods.
4. Ensure that no damage is done to structures or their protective coatings.

B. Backfilling Around Pipe:

1. Select material shall be used to backfill the trench from its bottom to one foot above the pipe. Prior to the laying of the pipe, the select material cushion shall be deposited in the trench and shall be leveled off, compacted, and shaped to obtain a smooth compacted bed providing firm uniform bearing along the laying length of the pipe.
2. After the pipe is installed, but prior to testing the line, select material shall be deposited in the trench evenly on both sides and along the full length of the pipe in 6-inch maximum loose lifts. If necessary, additional select material can be deposited over the center of each length of pipe to prevent undue movement during testing of the line. Ensure that initially placed material is tamped firmly under pipe haunches. The bell holes at the pipe joints shall not be backfilled at this time.
3. The pipeline shall then be tested. After the pipeline has passed the test, the Contractor shall backfill the bell holes with select material. The select material, which had been previously deposited over the pipe in the trench, shall be leveled and compacted.

C. Backfilling to Grade:

1. From an elevation one foot above the top of the pipe to grade, the backfill material shall be placed in layers not to exceed 12 inches in loose lifts each lift shall be compacted to a relative density not less than 90%.

2. If the trench section is flooded, no further backfill shall be placed for two (2) days. After this period, the backfill shall again be thoroughly compacted to a relative density of not less than 90% by a method and with equipment approved by the Engineer.
3. The Contractor shall reconstruct the base course and pavement of roadway damaged by the construction of the pipeline as covered elsewhere in these Detailed Specifications.
4. Other improvements such as driveways, sidewalks, curbs, gutters, stonewalls, fences and other structures damaged during construction shall be replaced or repaired to their original condition or better as approved by the Engineer.

END OF SECTION

SECTION 02226

ROADWAY EXCAVATION

PART 1 - GENERAL

1.1 GENERAL REQUIREMENTS

Roadway excavation shall consist of the removal and proper disposal of all materials necessary and required for the formation of the roadway prism, including the construction of the roadbed, parking lot, embankments, subgrade, the removal and disposal of surplus or unsuitable material, and the necessary excavation for the installation of gutters, and retaining wall along the right-of-way. It shall also include all of the above work necessary in connection with intersections, side roads, private roadways, approaches and the refilling of excavations caused by the removal of structures, tree roots, and the replacement of unsuitable material.

- A. It shall be the responsibility of the Contractor to examine the project site and determine for himself the existing conditions.
- B. Obvious conditions of the site existing on the date of the bid opening shall be accepted as part of the work, even though they may not be clearly indicated on the drawings and/or described herein or may vary therefrom.
- C. All debris of any kind accumulated from clearing shall be disposed of from the site, and the whole area left clean. The Contractor shall be required to make all necessary arrangements relative to the proposed place of disposal.

PART 2 - PRODUCTS (NOT USED)

PART 3 - EXECUTION

3.1 INSTALLATION

- A. Roadway excavation shall be done to the required subgrade to accept the new pavement structure. Subgrade shall be compacted with on-site excavated material approved by the Engineer when filling is required to bring the subgrade elevation to its required height. Subgrade preparation shall conform to the requirement as follows:
 - 1. Preparation. In advance of setting line and grade stakes, the subgrade area shall be cleared of brush, weeds, vegetation, and debris, all of which shall be satisfactorily disposed of to the satisfaction of the Engineer. All depressions and ruts which contain water shall be drained.

All unsuitable material, such as adobe, muck, expansive clay and materials with debris or organic matter, encountered above the road subgrade, shall be removed and hauled away from the project site. Unless a specific site is designated in the special provisions for disposal of unsuitable material, the Contractor is responsible to find a convenient site. The hauling and disposing of the unsuitable material shall be considered as incidental to the excavation work. The Engineer shall determine if the material is unsuitable.

2. Finished Subgrade. The finished subgrade shall have a density of at least 95% of its maximum density for a depth of 6 inches or more. The surface shall be rolled until the material does not creep under the roller and finished smooth to the required grade and cross section.
3. Protection of Subgrade. The subgrade shall be shaped and sloped to drain.
4. Surface Tolerance. The finished subgrade upon which subbase or base course is placed shall not vary more than 0.10 foot above or below the theoretical grade.

All unnecessary traffic shall be kept off the prepared subgrade. Should it become necessary to haul materials and aggregate over the prepared subgrade, the Contractor shall drag and roll the traveled way as frequently as may be necessary to remove ruts, cuts and breaks in the surface. The surface shall be brought up to grade, compacted and rolled smooth before placing the subsequent layer of specified material.

Should the prepared subgrade become soft, spongy, or yielding due to the weather or excessive sprinkling, the Contractor shall at his own expense remove and replace the soft material or let it dry out sufficiently, then recompact the material to the required density and grade.

END OF SECTION

SECTION 02230

AGGREGATE BASE COURSE

PART 1 - GENERAL

1.1 GENERAL REQUIREMENTS

- A. Description. This work shall consist of furnishing and placing one or more courses of aggregate base on a prepared surface in accordance with the requirements of the contract.

PART 2 - PRODUCTS

2.1 MATERIALS

Materials shall meet the requirements specified in the following Subsections of Division 700 Materials of the "Standard Specifications for Road and Bridge Construction."

Aggregate	703.06
Water	712.01

PART 3 - EXECUTION

3.1 CONSTRUCTION REQUIREMENTS

A Placing

1. The base material shall be placed on the prepared surface without segregation. Segregated materials shall be remixed until a uniform distribution is obtained. The material shall not be dumped in piles on the prepared surface.
2. Depositing and spreading shall commence at that part of the work farthest from the point of loading the material and shall progress continuously without breaks, unless otherwise directed by the Engineer.
3. If the required compacted depth of the base course exceeds 6 inches, the base shall be constructed on 2 or more layers of approximately equal thickness. The maximum compacted thickness of any one layer shall not exceed 6 inches.
4. If the contractor uses a vibratory roller weighing 9 tons or more, the lift thickness may be increased to 7 inches.

5. Spreading of binder material over the surface of the compacted base will not be permitted. Additional material if required shall be incorporated uniformly throughout the thickness of the compacted material by scarifying and blading. The combined material shall meet all quality requirements as specified.

B. Shaping and compacting

1. The Contractor shall perform such shaping work as necessary and such that the finished base shall conform to the required grade and cross-section. The finished base where not controlled by adjacent structures or features shall not vary more than 0.04 foot above or below the theoretical grade.
2. Compaction of each layer shall continue until a density of not less than 95 percent of the maximum density, determined in accordance with the requirements of Subsection 106.09 - Special Test Methods, of the "Standard Specifications for Road and Bridge Construction, has been achieved. Field density determination will be made in accordance with Hawaii Test Method HWY-TC 1. The surface of each layer shall be maintained during the compaction operations in such a manner that a uniform texture is produced and the aggregates firmly keyed. Water shall be uniformly applied over the base materials during compaction in the quantity necessary for proper consolidation. All cost of testing shall be borne by the Contractor.
3. Should high or low spots develop during rolling operations, such spots shall be smoothed out by blading with a self-propelled and pneumatic-tired motor grader having a wheel base not less than 15 feet long and a blade not less than 10 feet long.
4. Each layer shall be compacted initially by rolling with three-wheel rollers followed by intermediate rolling with pneumatic-tired rollers. Final rolling shall be done with three-wheel rollers.

- C. Equipment. Three-wheel rollers and pneumatic-tired rollers shall conform to the requirements specified in Subsection 401.03(B)(4) - Rollers.

END OF SECTION

SECTION 02362

SOIL TREATMENT FOR VEGETATION CONTROL

PART 1 - GENERAL

1.1 GENERAL REQUIREMENTS

The work to be performed under this section shall include spraying weed killer on the prepared roadway subgrade prior to the installation of the base course and where called on the plans and on existing growth prior to application of asphalt in the case of resurfacing jobs.

1.2 SUBMITTALS

Prior to the start of work, the contractor shall submit to the Engineer the material product data and Material Safety Data Sheets for the material proposed for use.

PART 2 - PRODUCTS

2.1 MATERIALS

- A. Weed killer shall be "Casoron 4G", "Norosac 4G", or an approved equal for under asphalt application on new or rebuilt pavement.
- B. Weed killer shall be "Hyvar X", Roundup" or approved equal for application to existing weeds for resurfacing jobs.

PART 3 - EXECUTION

3.1 APPLICATION

- A. The under asphalt weed killer shall be mixed and uniformly spread using calibrated application equipment at the maximum rates permitted for "under asphalt" use and in strict accordance with the manufacturer's label. Base Course material shall be installed as soon as possible after applying the weed killer to preclude loss of germination inhibiting action.
- B. In treatment of existing growth on resurfacing jobs, the weed killer shall be mixed and uniformly sprayed in strict accordance with the manufacturer's label.
- C. Nut grass shall be retreated two (2) days after initial application and again if growth still exists.
- D. The Contractor shall notify the Engineer 24 hours before application of weed killer.

END OF SECTION

SECTION 02512

ASPHALTIC CONCRETE

PART 1 - GENERAL

1.1 GENERAL REQUIREMENTS

Asphaltic concrete shall consist of a mixture of mineral aggregate and bituminous material, mixed at a central plant in the proportions hereinafter specified and spread and compacted on a prepared base or existing road surface.

The pavement may consist of a surface course mixture and leveling or base course mixture, as hereinafter specified.

PART 2 - PRODUCTS

2.1 MATERIALS

All materials shall meet the requirements specified in the State of Hawaii, Department of Transportation "Hawaii Standard Specifications for Road and Bridge Construction," latest edition, with the following subsections of Division 700 - Materials.

Bituminous Material (Asphalt Cement, Grades AR 40 or 80)	702.01
Asphalt Paint (Emulsified Asphalt)	702.04
Aggregate	703.09
Filler	703.15
Blending Sand	703.22
Hydrated Lime	712.03

Leveling or base course mixture shall be Mix No. 5, surface wearing course mixture shall be as shown on the plans or called for in the special provision or proposal.

- A. Grading and Composition Requirements: Materials composing the asphalt concrete shall be combined to meet the requirements set forth in Table 1. The grading composition limits specified are based on materials of uniform specific gravity. Correction of grading limits shall be made to compensate for any variations in specific gravity of the individual sizes.

<u>Compacted Thickness Individual Layers</u>	<u>Base and Leveling Course</u>	<u>Roadway Mixes</u>		
		(Std.)	(Dense Grade)	Resurfacing Mix
Minimum	1-1/2"	1-1/4"	1-1/4"	3/4"
Maximum	2-1/2"	2-1/2"	2-1/2"	1-1/2"

TABLE 1-GRADING AND COMPOSITION REQUIREMENTS

MIX NO.	2	3	4	5
<u>SIEVE SIZE</u>	<u>COMBINED AGGREGATE Total Percent Passing by Weight</u>			
1-1/4"	100	-	-	-
1"	85-100	100	-	-
3/4"	-	90-100	100	-
1/2"	60-85	70-90	85-100	100
3/8"	-	-	72-88	80-100
No. 4	36-55	40-57	48-66	55-75
No. 8	26-41	30-47	32-48	35-52
No. 16	17-32	20-36	21-37	22-38
No. 30	12-25	16-28	15-27	14-26
No. 50	8-18	10-22	9-21	8-20
No. 100	5-14	8-17	6-16	6-15
No. 200	1- 8	4-10	4-10	4-10
<u>Percentage by weight of Asphaltic Cement to be Added</u>	4.5-6.5	5.0-7.0	6.0-8.0	5.0-7.0

The grading within the above tolerances shall be to the percentage of aggregate passing the sieves during any day's run will conform to the following limitations:

Passing No. 4 and larger sieves	7% above or below
Passing No. 8 and No. 100 sieves	4% above or below
Passing No. 200 sieves	2% above or below
Bituminous Binder	0.4% above or below
Temperature of Mixture on Delivery	20°F above or below

PART 3- EXECUTION

3.1 DETAILS

- A. **Mixing:** The asphaltic cement shall be heated in a kettle of approved type, and maintained at a temperature between 275NF and 300NF. The heat must be so applied that there can be no burning of any portion of the asphaltic cement. No live steam shall be injected into the cement. The mineral aggregate shall be heated in an approved appliance to a temperature of not less than 275NF nor more than 320NF.

After heating to the required temperature, the required amount of asphalt cement shall be added to the heated aggregate. This mass shall be introduced into the mixer within 25NF of each other's temperature.

- B. **Prime Coat:** All surfaces on or against which asphalt concrete is to be placed shall first be given an asphaltic cement prime or tack coat as specified in Section 02513, "Prime Coat," of these specifications.

Before applying the prime and tack coat, the Contractor shall prepare the existing surfaces by power brooming to remove all loose particles, dust, sand, and other foreign materials.

- C. **Asphaltic Concrete Interlayer Fabric Membrane:** Immediately after installation of the prime coat and prior to installation of the asphaltic concrete wearing surface the interlayer fabric membrane is to be installed in accordance with Section 02517.

- D. **Laying Wearing Surface:** In advance of placing asphalt concrete over an existing base, surfacing, or pavement, and after the base, surfacing, or pavement has been prepared as herein specified, and if ordered by the Engineer or shown on the plans, a leveling course mixture shall be spread to level irregularities, dips, depressions, sags, and excessive crown, and to provide a smooth base of uniform grade and cross-section in order that the surface course will be of uniform thickness. The above specified material shall not be placed more than one day in advance of placing the surface course. No additional compensation will be allowed for placing leveling course mixture as specified above and full compensation for all work incidental to such operations shall be considered as included in the contract prices or price paid for the asphalt concrete mixture used.

The mixture as prepared above shall be brought to the work in suitable vehicles at a temperature of not less than 250NF. Tarpaulins shall be provided and used upon all loads.

The wearing surface shall be spread with self-propelled mechanical spreading and finishing equipment, provided with a screed or strike-off assembly capable of distributing not less than the full width of a traffic lane. The screed shall be adjustable to the required crown and elevation. Screeding includes any cutting, crowding or other action which is effective on the mixture without tearing, shoving, or gouging, and which produces a finished surface

of an even texture. The equipment shall be provided with rolling, tamping, or other suitable compacting devices, and shall be operated with a forward speed of not more than 20 feet per minute.

If the spreading and finishing equipment leaves ridges, indentations, or other marks in the surface that cannot be eliminated by rolling or prevented by adjustment in operation, its use shall be discontinued and other acceptable equipment shall be furnished by the Contractor.

If more than one course is to be laid in any area, not more than 24 hours shall elapse between the spreading and finishing of any two successive courses in that area.

The self-propelled mechanical spreading and finishing machine shall be capable of propelling the vehicle being unloaded in uniform manner and, if necessary, the load of the haul vehicle shall be so limited that satisfactory spreading will be obtained. While being unloaded, the vehicle shall be firmly attached to the machine and the brakes on the vehicle shall not be depended upon to obtain contact between the vehicle and the machine.

Before placing asphalt concrete wearing surface adjacent to cold transverse construction joints, such joints shall be trimmed to a vertical face in a neat line. The location of the proposed joint shall be tested with a 10-foot straight-edge and cut back such that when the straight-edge is laid on the finished surface parallel with the center line of the street, the surface shall in no place vary from the lower edge of the straight-edge more than 1/8 inch.

Before placing asphalt concrete adjacent to any existing asphalt concrete, the face of the existing asphalt concrete shall be trimmed to a vertical face in a neat line.

Where asphalt concrete wearing surface is placed adjacent to a Portland cement concrete gutter, the asphalt concrete wearing surface shall be so laid that its surface, after compaction, will approximately be 1/4-inch above the surface of the adjacent concrete. The edge of the asphalt concrete wearing surface shall then be smoothed and sealed over a width of approximately 3 inches with hot hand-irons having a self-contained heating unit.

At locations where the width of asphalt concrete mixture to be spread is too narrow to permit the use of self-propelled mechanical spreading and finishing equipment, or where the surfacing is to extend to a featheredge and the use of such a machine is not practicable, the mixture may be spread by hand-raking. Where hand-raking is permitted, the mixture shall be finally shaped and smoothed by means of a wooden float 8 feet long, one-inch thick and 4 inches wide. The float shall be rigidly ribbed, and to insure a true and flat surface on the underside, adjusting screws shall be placed between the rib and float at not more than 24-inch centers. The float shall be operated by means of a long handle, from the side of the area being paved or surfaced, and parallel with the center line of the pavement or surfacing. High spots and irregularities that are transverse to the path of traffic shall be

cut down and the material redistributed over the area. The maximum depth of wearing surface which may be spread and rolled in one course shall not exceed a compacted thickness of 2 inches. Where such thickness exceeds 2 inches, it shall be spread and rolled in courses each not to exceed a compacted thickness of 1-1/2 inches unless otherwise specified in these specifications.

Wearing surface mixture shall not be spread from hauling vehicles.

No wearing surface shall be spread when the atmospheric temperature is below 50°F or during other unsuitable weather, or when the base is wet.

- E. Rolling: Immediately after the wearing surface has been laid as specified above, it shall be compressed with power rollers, smooth running, and in first-class mechanical condition. Initial rolling or tamping shall be performed when the temperature of the mixture is between 220°F and 245°F.

After the first pass of the roller, any low or grainy spots shall be broken up with a hot rake and more material worked in to insure a surface of uniform texture and maximum density. Rolling equipment shall be self-propelled. Initial rolling of asphalt concrete mixtures shall be performed by means of a three-wheeled roller weighing not less than 12 tons and with a compression on the rear wheels of not less than 325 pounds per linear inch of tire width, or in lieu thereof, by means of a three-axle tandem roller weighing not less than 12 tons. For production not exceeding 150 tons per hour, not less than one of the above specified rollers shall be used for initial rolling. For productions in excess of 150 tons per hour, one additional roller of a type designated by the Engineer will be required for each additional 100 tons or fraction thereof of asphalt concrete mixture placed.

Three-axle-tandem type rollers shall be so constructed that the rolls, when locked in position for all treads to be in one plane, are held with a rigidity which will permit the following test under full load. With the weight of the roller supported on the central roll, the tread of the central roll shall not be more than 1/8-inch above the plane tangent to the treads of the end rolls. With the weight of the roller supported on the end rolls, the tread of the central roll shall not be more than 1/4-inch below the plane tangent to the treads of the end rolls.

In general, three-axle tandem roller shall not be used in rolling over a crown or on warped surfaces when the axle is in a locked position.

Finishing rolling of asphalt concrete mixtures shall be performed by means of a tandem roller weighing not less than 10 tons.

Rolling shall continue until the compressed pavement or surfacing has a relative specific gravity of not less than 95 percent of the specific gravity of the combined mixture without voids.

- F. Smoothness: The finished surface of the pavement shall be true to grade and cross-section, free from depressions, or grainy spots, and shall show a uniform distribution of aggregate.

When a straight-edge, 10 feet long, is laid on the finished surface parallel to the center line of the pavement, the surface shall in no place vary from the lower edge of the straight-edge more than $\frac{3}{16}$ of an inch.

No traffic shall be permitted on any course of asphalt concrete until it has cooled and set, except such traffic as may be necessary for construction purposes.

END OF SECTION

SECTION 02514

TACK COAT

PART 1 - GENERAL

1.1 GENERAL REQUIREMENTS

This section covers the requirements for furnishing and installing bituminous tack coat.

PART 2 - PRODUCTS

2.1 All sections or subsections called for in the specifications shall be referred to the State of Hawaii, Department of Transportation, "Hawaii Standard Specifications for Road and Bridge Construction," 1985.

2.2 MATERIALS

Bituminous material for tack coat shall be slow-setting emulsified asphalt, Type SS-1 or Type SS-1H, conforming to the applicable requirements of Section 407 - Bituminous Tack Coat.

Water shall conform to the requirements of Subsection 712.01 - Water.

PART 3 - EXECUTION

3.1 CONSTRUCTION REQUIREMENTS

- A. Weather Limitations: Tack coat shall not be applied on a wet surface or when weather conditions otherwise shall prevent proper construction.
- B. Equipment: The Contractor shall provide equipment for heating and applying the bituminous material. This equipment shall meet the requirements of Subsection 405.03(B) - Equipment.
- C. Preparation of Surface: Immediately before applying the tack coat, the surface to be treated shall be swept clean of all loose material, dirt, excess dust or other objectionable matter. A power broom or power blower, supplemented by hand methods if necessary, shall be used.
- D. Application of Bituminous Material: The emulsified asphalt shall be diluted with water at a rate of one part emulsion to one part of water by volume. The quantity, rate of

application, temperature, and areas to be treated will be approved prior to application.

Tack coat shall be placed only so far in advance of the surface course placement as is necessary for it to cure to the proper condition for placement of such surface course.

Unless otherwise specified, tack coat shall be applied at the rate of 0.05 - 0.15 gallon per square yard on surface of base course.

Tack coat will not be measured for payment. Tack coat will be considered as incidental to the various contract items.

END OF SECTION

Tack Coat
02514-2

DIVISION 3 – CONCRETE

SECTION 03300

CONCRETE

PART 1 - GENERAL

1.1 GENERAL REQUIREMENTS

This specification covers the requirements for furnishing, hauling, mixing, placing, and curing of concrete.

1.2 SUBMITTALS

The Contractor shall submit concrete mix design for approval.

PART 2 - PRODUCTS

2.1 MATERIALS

- A. Portland cement shall conform to the requirements of ASTM C150, Type I, for all concrete work.
- B. Concrete Aggregates

- 1. Fine aggregates shall be calcareous or basalt sands, or a combination thereof. They shall meet the grading requirements of ASTM C33 unless the concrete producer can provide past data that show that a proposed non-conforming gradation will produce concrete with the required strength and suitable workability.

If manufactured sands are used in the concrete mix, the Contractor may select and use a water-reducing and/or an air-entraining admixture as specified hereinafter to provide satisfactory workability in the concrete. The cement content of a mix shall be as specified hereinafter, and the use of an admixture shall in no way result in the reduction of the cement factor.

- 2. Coarse aggregates shall be crushed close-grained, blue lava rock meeting the grading requirements of sizes 57 or 67 (ASTM D448) or both. The maximum size of aggregate shall not be larger than 1/5 of the narrowest dimensions between sides of the forms of the member for which the concrete is to be used not larger than 3/4 of the minimum clear spacing between individual reinforcing bars or bundles of bars.

C. Concrete Reinforcement

1. Reinforcing steel shall be deformed bars conforming to ASTM A615, grade as shown on plans.
2. Welded wire fabric for concrete reinforcement shall conform to ASTM A185 and shall be galvanized.
3. Metal accessories such as spaces, chairs, ties, and other devices necessary for properly placing, supporting and fastening reinforcement in place shall be provided. Chairs shall be galvanized. Annealed steel wire or not less than 16-gauge shall be used to secure reinforcement.

D. Water used in mixing concrete shall be potable.

E. Non-slip grit shall be an abrasive aggregate of silicon carbide or aluminum oxide.

F. Admixture, if used, shall conform to ASTM C494 or ASTM C260 and shall be mixed in proper amount in accordance with directions of manufacturer.

G. Curing compound shall conform to ASTM C309.

PART 3 - EXECUTION

3.1 DESIGN OF CONCRETE MIXES

- A. All concrete throughout shall be either job or plant mixture in an approved type of power operated mixer that will insure uniformity and homogeneity of the concrete produced.
- B. Mixing at jobsite shall be done in accordance with ACI 614.
- C. Ready-mixed and mixed-in-transit concrete shall be mixed to conform to the provisions of ASTM C94.
- D. Concrete shall be mixed only in such quantity as is required for immediate use. No retempering will be permitted and concrete that has started to harden shall be discarded and promptly removed from the job.
- E. Admixtures conforming to paragraph 2.1 may be used in the concrete as recommended by the supplier and approved by the Engineer.

3.3 PLACING CONCRETE

- A. No concrete shall be placed in the absence of the Engineer or his representative who shall be given one day advance notice of starting time of concrete pour.
- B. Preparation
 - 1. Concrete shall be placed upon clean, damp surfaces with no free water, or upon properly compacted fills but never upon soft mud or dry, porous earth.
 - 2. Before depositing new concrete on or against concrete which has set, all accumulation or mortar splashed upon reinforcing steel and the surfaces of forms shall be removed and the forms shall be retightened. The surfaces of previously set concrete shall be thoroughly roughened and cleaned of all foreign matter and laitance, saturated with water and slushed with a coat of cement grout. New concrete shall be placed before the grout has attained its initial set.
- C. Conveying
 - 1. Concrete shall be conveyed from mixer to forms as rapidly as practicable by methods that will prevent segregation.
 - 2. Concrete shall be deposited as nearly as practicable in its final position. Extensive spading as a means of transportation shall be avoided and in no case shall vibrators be used to transport concrete inside forms.
 - 3. Open troughs and chutes shall have a slope not to exceed 1 vertical to 2 horizontal and not less than 1 vertical to 3 horizontal. Chutes more than 20 feet long and chutes not meeting the slope requirements may be used provided they discharge into a hopper before distribution.
 - 4. The concrete shall not be allowed to drop freely more than six feet except where specifically authorized by the Engineer. When placing operations would involve the dropping of concrete from a height of more than six feet it shall be conveyed through pipes or flexible drop chutes.
 - 5. If any appreciable segregation occurs through the conveying methods employed, their use shall be ordered discontinued by the Engineer and some other satisfactory method of placing concrete shall be used.
 - 6. All chutes, troughs, pipes and other means of conveyance shall kept clean and free from coatings of hardened cement or concrete by thoroughly cleaning with water and chipping after each pour. Water used for flushing shall be discharged away from the vicinity of the concrete or forms already in place.

D. Depositing

1. Unless adequate protection is provided, concrete shall not be placed during rain. Rainwater shall not be allowed to increase the mixing water nor to damage the surface finish. Fresh concrete that has been deposited but has not attained its initial set shall be protected in the event of rain.
2. Placing of the concrete shall be started at the far end of work so that each batch will be dumped against previously placed concrete, not away from it.

E. Compaction

1. All concrete shall be consolidated by vibration so that the concrete is thoroughly worked around the reinforcement, around embedded items, and into corners of forms, eliminating all air or stone pockets which may cause honey-combing, pitting, or planes of weakness. All compaction shall be done by use of high frequency internal vibrators. Where the vibrator cannot be inserted into the concrete, compaction shall be done by spading, rodding, or forking.
2. Frequency of vibrator shall be not less than 7,000 impulses per minute. The Contractor shall provide a sufficient number of vibrators to properly consolidate all concrete immediately after placing. At least one standby vibrator shall be on hand at all times during placement of the concrete.

3.4 REINFORCEMENT

- A. Reinforcing steel bars, wire and wire fabric shall be provided in the sizes, length and configurations as indicated on plans and shall be thoroughly cleaned, before placing, of loose mill scale, loose flaky rust, oil, and all coatings that will destroy or reduce bond. If necessary, they shall be cleaned again before placing of concrete. All items shall be fabricated, positioned and secured in place as indicated in the plans and as herein specified. Annealed steel wire of not less than 16-gauge shall be used to secure reinforcement. Unless otherwise noted, cleaning, bending and placing of reinforcement shall be done in accordance with the standard practice of the Concrete Reinforcing Steel Institute.
- B. Concrete or metal support and spacers shall be used to secure the proper spacing of reinforcement over formwork. Stirrups shall be accurately and securely wired to the bars at both top and bottom. At slabs, footings and beams in contact with earth, pre-cast concrete blocks (not bricks or hollow tile) shall be used to hold reinforcement at a proper distance above earth.

- C. Bars shall be tied at all intersections, and distances from forms shall be maintained by means of pre-cast concrete blocks, ties, hangers or other approved supports.
- D. Bars shall be bent cold to the shapes shown on the plans. Bends shall be made around a pin having a diameter not less than 6 times the bar diameter except that for bars of larger than 1-inch diameter the pin diameter shall be 8 times the bar diameter. If required, bars may be bent in the field using a "hickey" bar.
- E. All reinforcing steel bars shall be furnished in the lengths indicated on the plans. Splicing of bars, except where shown, will not be permitted without the approval of the Engineer.

3.5 CONCRETE SLABS ON GRADE

- A. Concrete slabs on earth shall be placed over a structural fill as specified in another section.
- B. All slabs shall be reinforced with 6 x 6 - W1.4 by W1.4 welded wire fabric unless otherwise shown or called for on the plans.
- C. Care shall be taken in handling and placing the reinforcement as follows:
 - 1. Reinforcing fabric shall not be rolled over by trucks, buggles or wheelbarrows, nor trampled to the extent that it is bent out of the plans of the fabric. Material which has been so bent that it cannot be laid out flat shall be rejected.
 - 2. Reinforcing fabric shall be positively set, either prior to or during the placement of concrete, to the levels required within the slabs as indicated on the plans or as otherwise called for herein.
- D. A bond-break filler shall be provided where edge of slab abuts any vertical surface and where indicated on plans. Width of filler strips shall equal depth of floor slab.

3.6 FINISHING OF SLABS

- A. Broom Finish for Slabs: The concrete slabs shall be given a coarse transverse scored texture by drawing a broom across the surface. The operation shall follow immediately after steel trowelling.

3.7 REPAIR OF DEFECTS

- A. After forms have been removed, any concrete which is not constructed as shown on the plans or is out of alignment or level beyond required tolerances or which shows a defective surface which in the opinion of the Engineer cannot be properly repaired or patched shall be removed.

- B. Where concrete which is exposed to view requires repairing or patching, the texture of the surface of such repair or patch shall closely match that of the surrounding surface.

3.8 CURING AND PROTECTION

- A. All concrete shall be cured for a period of not less than seven (7) days by one of the methods listed below. During this curing period, the concrete shall be maintained with minimal moisture loss at a relatively constant temperature. Fresh concrete shall be protected from heavy rains, flowing water, mechanical injury, and injurious action of the sun. Curing method selected must be compatible with the finish to be applied to the concrete.

Curing shall immediately follow the finishing operation.

- B. Water Curing: If cured with water, concrete shall be kept wet by mechanical sprinklers, by ponding, or by any other method which will keep the surfaces continuously wet.
- C. Saturated Sand Curing: Surfaces cured with sand shall be covered with a minimum of one inch thickness of sand which shall be kept uniformly distributed and continuously saturated during the entire curing period.
- D. Curing Compounds: Curing compounds shall not be used on concrete surfaces that are to receive paint finish, acid stain or resilient flooring, except those that are recommended by the manufacturer to be compatible with the applied finish. The Contractor shall submit to the Engineer a letter certifying that the curing compound is compatible with the applied finish. Application shall be in accordance with the manufacturer's recommendations. If curing, sealing or other compounds are used which are incompatible with applied finish, such compound shall be thoroughly removed by grinding with a terrazo grinder.
- E. Waterproof Paper: Waterproof paper or opaque polyethylene film conforming to ASTM C171 may be used. The paper or film shall be anchored securely and all edges sealed or applied in such a manner as to prevent moisture escaping from the concrete.

3.9 SAMPLING AND TESTING

- A. Sampling - ASTM C 172: Collect samples of fresh concrete to perform tests specified. ASTM C 31 for making test specimens.
- B. Slump Tests - ASTM C 143: Take concrete samples during concrete placement. The maximum slump may be increased as specified with the addition of an approved admixture provided that the water-cement ratio is not exceeded. Perform tests at commencement of concrete placement, when test cylinders are made, and for each batch (minimum) or every 10 cubic yards (maximum) of concrete.

- C. Compressive Strength Tests - ASTM C 39: Make four test cylinders for each set of tests in accordance with ASTM C 31. Test one cylinder at 7 days, two cylinders at 28 days, and hold one cylinder in reserve. Provide concrete cylinders for compression tests not less than once a day, nor less than once for each 100 cubic yards of concrete, nor less than once for each 5,000 square feet of surface for slabs or walls. If the average strength of the 28-day test cylinders is less than f'_c and a maximum of one single cylinder is less than f'_c minus 300 psi, take three ASTM C 42 core samples and test. If the average strength of the 28-day test cylinders is less than f'_c and two or more cylinders are less than f'_c minus 300 psi, take six core samples and test. Concrete represented by core tests shall be considered structurally adequate if the average of the three cores is equal to at least 85 percent of f'_c and if no single core is less than 80 percent of f'_c . Locations represented by erratic core strengths shall be retested. Remove concrete not meeting strength criteria and provide new, acceptable concrete at no additional cost to the State. Repair core holes with nonshrink grout. Match color and finish of adjacent concrete.
- D. Testing: All sampling and testing shall be performed by an independent testing agency and all test results submitted to the Engineer for approval. All cost of sampling and testing shall be borne by the contractor.

END OF SECTION