



DEPARTMENT OF THE ARMY
U.S. ARMY CORPS OF ENGINEERS, HONOLULU DISTRICT
230 OTAKE STREET, CEPOH-RO
FORT SHAFTER, HAWAII 96858-5440

January 23, 2025

SUBJECT: Nationwide Permit Verification for DLNR, Mala Boat Ramp Maintenance Dredging, Lahaina, Island of Maui, Hawaii Department of the Army File No. POH-2016-00220

Meghan Statts
DLNR DOBOR
4 Sand Island Access Road
Honolulu, HI 96819

Dear Ms. Statts:

The Honolulu District, U.S. Army Corps of Engineers (Corps), Regulatory Branch has completed review of your Pre-Construction Notification dated November 22, 2024, requesting authorization for the proposed Mala Boat Ramp maintenance dredging located at Mala Boat Ramp at the end of Unahiole Sreet, Lahaina, Island of Maui, HI. Please reference Department of the Army (DA) file number POH-2016-00220 in any future correspondence related to this permit.

This Nationwide Permit (NWP) verification letter is being issued pursuant to Section 10 of the Rivers and Harbors Act of 1899 for work or structures in or affecting navigable waters of the U.S. You are authorized to conduct the following activities:

- The maintenance dredging of up to 0.57 acres of marine waters surrounding Mala Boat Ramp. The project will use a barge-mounted excavator to remove up to 3,350 cubic yards of sediment to return the basin to design depths of -7 feet below Mean Lower Low Water (MLLW). Dredged material will be placed in an upland location. Project best management practices (BMPs), including a full-depth floating turbidity curtain around the dredging area, will be implemented during work and removed from waters after completion of dredging.

Based upon the information and plans you provided, we hereby verify that the work described above, which would be performed in accordance with the enclosed plans (Enclosure 1), complies with the terms and conditions of and is authorized by NWP 35, (Maintenance Dredging of Existing Basins) issued on February 25, 2022. The full text of NWP 35 and its associated Regional and General Conditions can be accessed at: <https://www.poh.usace.army.mil/Missions/Regulatory/Permits/Nationwide-Permits/>. You must comply with all terms and conditions associated with NWP 35, as well as with the special conditions listed below:

a. You must implement and abide by the applicable Pac-SLOPES BMPs (Enclosure 2) including completion of the monitoring form (Enclosure 3).

b. You must implement and abide by the applicable EFH Conservation Recommendations (Enclosure 4).

c. Your use of the permitted activity must not interfere with the public's right to free navigation on all navigable waters of the U.S.

d. In-water work will cease during the coral spawning peak from June 14th, 2025-July 5th, 2025, to minimize impacts to coral larvae.

Verification of your project under this NWP is valid until **March 14, 2026**, unless this NWP is modified, reissued, or revoked prior to that date. It is incumbent upon you to remain informed of changes to the NWPs. If the Corps modifies, reissues, or revokes any NWP at an earlier date, we will issue a public notice announcing the changes. Failure to comply with all terms and conditions of this NWP verification invalidates this authorization and could result in a violation of the Rivers and Harbors Act and subsequent enforcement action.

This authorization does not relieve you of the responsibility to obtain any other federal, state, and/or local authorizations required by law.

Your project complies with the requirements of the Clean Water Act, Section 401 Blanket Water Quality Certification (WQC) WQC1092 issued for this Nationwide Permit by the State of Hawaii Department of Health, Clean Water Branch. You are responsible for complying with the attached General Conditions of this WQC (Enclosure 5).

Your project complies with the requirements of the Coastal Zone Management Consistency Concurrence for this NWP issued by the State of Hawaii Department of Business, Economic Development and Tourism, Office of Planning during the NWP reissuance process in 2021.

Finally, General Condition 30 requires a signed certification be submitted to this office upon completion of work. Therefore, please sign, date and return the enclosed *Compliance Certification* form (Enclosure 6) within 30 days of completion of work to the email address specified below or to the mailing address indicated on the letterhead above.

Thank you for your cooperation with the Honolulu District Regulatory Program. Should you have any questions related to this authorization, please contact me at 808-551-5496 or via e-mail at Jeremy.K.Morgan@usace.army.mil and [CEPOH-](#)

RO@usace.army.mil, referencing the project number POH-2016-00220 in the email subject. You are encouraged to provide comments on your experience with the Honolulu District Regulatory Branch by accessing our web-based customer survey form at <https://regulatory.ops.usace.army.mil/customer-service-survey/>.

Sincerely,

A handwritten signature in black ink, appearing to read "Jeremy Morgan".

Jeremy Morgan
Regulatory Specialist, Regulatory Branch

Enclosures

cc:

Sea Engineering, Inc., Greg Wong gwong@seaengineering.com

State of Hawaii Department of Health, Clean Water Branch

Darryl C Lum darryl.lum@doh.hawaii.gov

CleanWaterBranch@doh.hawaii.gov

State of Hawaii Office of Planning, Coastal Zone Management Program

Debra.L.Mendes@hawaii.gov

U.S. Coast Guard, SecHonoWaterWays@uscg.mil

USCG District 14 Waterways Management, d14-dg-pj-dpw@uscg.mil

STATE OF HAWAII
DEPARTMENT OF LAND AND NATURAL RESOURCES
ENGINEERING DIVISION

FOR

DIVISION OF BOATING AND OCEAN RECREATION

JOB NO. MA23-04

**MALA BOAT RAMP
MAINTENANCE DREDGING**

LAHAINA, MAUI, HAWAII

60% (DRAFT) PLANS SUBMITTAL

TAX MAP KEYS AFFECTED:

(2)4-5-005:001

(2)4-5-004:011

OWNER: STATE OF HAWAII

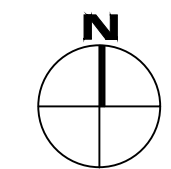
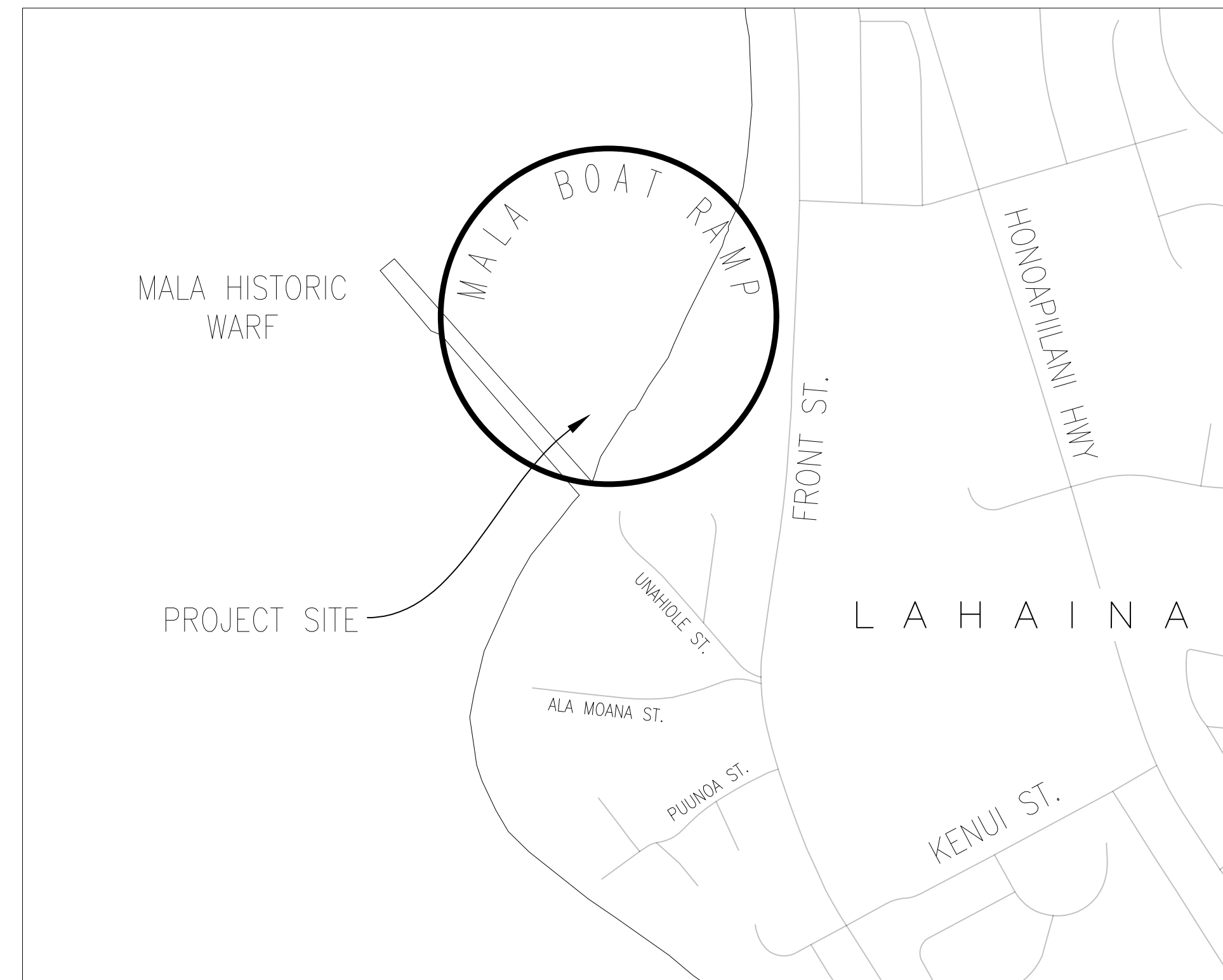

VICINITY MAP
SCALE: NTS

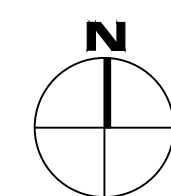

LOCATION MAP
SCALE: NTS

INDEX OF DRAWINGS

SHT. No.	DWG. No.	DESCRIPTION
1	T-1	TITLE SHEET
2	G-1	GENERAL NOTES & ABBREVIATIONS
3	C-1	PROJECT CONTROL NETWORK
4	C-2	DREDGING SITE PLAN
5	C-3	STOCKPILE AREA & ENVIRONMENTAL CONTROLS
6	C-4	DREDGE PLAN CROSS SECTIONS - 1
7	C-5	DREDGE PLAN CROSS SECTIONS - 2
8	C-6	DREDGE PLAN CROSS SECTIONS - 3

APPROVED: _____ DATE: _____

EDWARD R. UNDERWOOD
ADMINISTRATOR
DIVISION OF BOATING AND OCEAN RECREATION
DEPARTMENT OF LAND AND NATURAL RESOURCES

APPROVED: _____ DATE: _____

CARTY S. CHANG, P.E.
CHIEF ENGINEER
ENGINEERING DIVISION
DEPARTMENT OF LAND AND NATURAL RESOURCES

60% DRAFT PLANS

DRAWING NO.
T-1

/Users/goodster/Library/CloudStorage/OneDrive-SanEugene/Engineering/Lahaina & Mala Dredge/DWG/60_PCT/Mala/WORKING REVISIONS/20240909/1 - T-1 - TITLE PAGE.dwg, Thu Sep 12 14:53:05 2024, ANS 1:1, *** NOT FOR CONSTRUCTION ***

DRAFT PLANS - NOT FOR CONSTRUCTION

GENERAL NOTES:

- THE PROJECT OBJECTIVE IS TO DREDGE, REMOVE, AND DISPOSE OF ALL SAND AND UNCONSOLIDATED SEDIMENT WITHIN THE SPECIFIED DREDGE LIMITS, TO ACHIEVE THE SPECIFIED DREDGE DEPTHS. THE PROJECT CONSISTS OF MAINTENANCE DREDGING ONLY. THE CONTRACTOR SHALL NOT DREDGE INTO UNDISTURBED HARD BOTTOM.
- CONTRACTOR SHALL PROVIDE TWO WEEKS NOTICE TO LAHAINA SBH HARBOR AGENT PRIOR TO START OF DREDGING.
- ALL DISTANCES, DIMENSIONS, ELEVATIONS, AND COORDINATES ARE IN FEET, UNLESS NOTED OTHERWISE.
- THE CONTRACTOR SHALL CHECK AND VERIFY ALL DIMENSIONS AND DETAILS SHOWN IN THESE PLANS PRIOR TO THE START OF CONSTRUCTION. ANY DISCREPANCY SHALL BE IMMEDIATELY BROUGHT TO THE ATTENTION OF THE ENGINEER FOR DIRECTION.
- WORK INCIDENTAL TO THE CONTRACT AND NECESSARY TO COMPLETE THE PROJECT, ALTHOUGH NOT SPECIFICALLY REFERRED TO ON THE CONTRACT DOCUMENTS, SHALL BE FURNISHED AND PERFORMED BY THE CONTRACTOR AT NO ADDITIONAL COST.
- THE CONTRACTOR SHALL MAKE ARRANGEMENTS FOR UTILITIES INCLUDING BUT NOT LIMITED TO ELECTRICITY, WATER, ETC., REQUIRED FOR THEIR OPERATIONS, AND ALL ASSOCIATED COSTS SHALL BE BORNE BY THE CONTRACTOR.
- CONTRACTOR SHALL NOT PERFORM ANY CONSTRUCTION OPERATION SO AS TO CAUSE FALLING ROCKS, SOIL, OR DEBRIS IN ANY FORM TO FALL, SLIDE OR FLOW ONTO ADJOINING PROPERTIES, STREETS, OR NATURAL WATERCOURSES. SHOULD SUCH VIOLATIONS OCCUR, THE COSTS INCURRED FOR ANY REMEDIAL ACTION SHALL BE PAID BY THE CONTRACTOR.
- THE CONTRACTOR SHALL BE RESPONSIBLE FOR THE CLEARING AND REMOVAL OF ALL SAND, MUD, AND OTHER DEBRIS DEPOSITED AND ACCUMULATED ON ROADWAYS, WALKWAYS, AND OTHER IMPROVED AREAS AS A RESULT OF THEIR CONSTRUCTION ACTIVITIES.
- THE CONTRACTOR SHALL BE RESPONSIBLE FOR MAINTAINING THE PROJECT AREA, STREETS, SIDEWALKS, AND OTHER PUBLIC RIGHT OF WAYS IN A CLEAN AND ORDERLY MANNER, AND FOR CLEARING AND REMOVAL OF ALL DEBRIS GENERATED BY ASSOCIATED CONSTRUCTION ACTIVITIES. ALL SPILLS OF SAND, ROCK, OR CONSTRUCTION DEBRIS SHALL BE REMOVED IMMEDIATELY. ALL AREAS ADJACENT TO DESIGNATED WORK AREAS SHALL BE MAINTAINED IN A CLEAN, SAFE AND USABLE CONDITION.
- ALL EXISTING UTILITIES, ROADWAYS, WALKWAYS, WALLS, AND BUILDINGS, WHETHER OR NOT SHOWN ON THESE PLANS, SHALL BE PROTECTED FROM DAMAGE AT ALL TIMES DURING CONSTRUCTION. ANY DAMAGE TO THEM SHALL BE REPAIRED BY THE CONTRACTOR AT THEIR EXPENSE.
- THE CONTRACTOR SHALL NOTIFY ALL APPROPRIATE AGENCIES TO VERIFY THE ACTUAL LOCATION OF ALL UTILITIES IN THE PROJECT AREA PRIOR TO ANY EXCAVATION. THE CONTRACTOR SHALL NOTIFY THE ONE CALL CENTER AT (866) 423-7287 OR 811 AT LEAST FIVE (5) WORKING DAYS PRIOR TO THE START OF EXCAVATION. PERSONAL INJURY RESULTING FROM CONTACT WITH EXISTING UTILITIES SHALL BE THE CONTRACTOR'S RESPONSIBILITY.
- ALL PROJECT WORK, INCLUDING DEMOLITION, STOCKPILING, AND GRADING, SHALL BE PERFORMED IN CONFORMANCE WITH APPLICABLE FEDERAL AND LOCAL LAWS AND REGULATIONS REGARDING WATER QUALITY AND WATER POLLUTION CONTROL. THE CONTRACTOR SHALL BE RESPONSIBLE FOR CONFORMANCE WITH THE APPLICABLE PROVISIONS OF CHAPTER 54, WATER QUALITY STANDARDS, AND CHAPTER 55, WATER POLLUTION CONTROL, OF TITLE 11, HAWAII ADMINISTRATIVE RULES OF THE STATE DEPARTMENT OF HEALTH. BEST MANAGEMENT PRACTICES SHALL BE EMPLOYED AT ALL TIMES DURING CONSTRUCTION.
- THE CONTRACTOR SHALL OBSERVE AND COMPLY WITH ALL FEDERAL, STATE, AND LOCAL LAWS REQUIRED FOR THE PROTECTION OF PUBLIC HEALTH AND SAFETY AND ENVIRONMENTAL QUALITY.
- THE CONTRACTOR, AT HIS OWN EXPENSE SHALL KEEP THE PROJECT AND ITS SURROUNDING AREAS FREE FROM DUST NUISANCE, RUBBISH, NOISE, EROSION, ETC. THE WORK SHALL BE IN CONFORMANCE WITH THE AIR AND WATER POLLUTION CONTROL STANDARDS AND REGULATIONS OF THE HAWAII STATE DEPARTMENT OF HEALTH.
- ALL CONSTRUCTION WORK SHALL IMPLEMENT MEASURES AND/OR CONTROLS SUFFICIENT TO ENSURE THAT THE DISCHARGE OF POLLUTANTS FROM THE CONSTRUCTION SITE WILL BE REDUCED TO THE MAXIMUM EXTENT PRACTICABLE AND WILL NOT CAUSE OR CONTRIBUTE TO AN EXCEEDANCE OF STATE AND NATIONAL WATER QUALITY STANDARDS.
- THE JOB SITE MUST BE LEFT IN A SAFE AND SECURE CONDITION AT THE END OF EACH CONSTRUCTION WORK DAY. CONTRACTOR SHALL REGULARLY CLEAN UP AND REMOVE FROM THE JOB SITE ALL GENERATED RUBBISH AND MAINTAIN THE PREMISES IN A CLEAN AND ORDERLY CONDITION AT ALL TIMES.
- ALL EXISTING TREES, SHRUBS, AND SURROUNDING VEGETATION SHALL BE PRESERVED AND PROTECTED AS FAR AS PRACTICABLE. REMOVAL OF ANY TREES SHALL REQUIRE PRIOR APPROVAL BY THE ENGINEER. ANY DAMAGED VEGETATION SHALL BE REPLACED BY THE CONTRACTOR AT THEIR EXPENSE.
- CONTRACTOR SHALL OBTAIN AND PAY FOR ALL REQUIRED CONSTRUCTION PERMITS FROM THE APPROPRIATE REGULATORY AGENCIES.
- STATE OF HAWAII DLNR WILL DELEGATE THE CONTRACTOR AS THE AUTHORIZED REPRESENTATIVE TO SUBMIT ALL NECESSARY DOCUMENTS AND REPORTS AS REQUIRED BY THE DEPARTMENT OF HEALTH AND US ARMY CORPS OF ENGINEERS DIRECTLY TO THEIR OFFICES AT NO COSTS TO THE STATE.
- THE CONTRACTOR SHALL ASSUME SOLE AND COMPLETE RESPONSIBILITY FOR JOB SITE CONDITIONS DURING THE COURSE OF CONSTRUCTION OF THIS PROJECT.
- WHERE PEDESTRIAN WALKWAYS EXIST, THEY SHALL BE MAINTAINED IN PASSABLE CONDITION OR OTHER FACILITIES FOR PEDESTRIANS SHALL BE PROVIDED. TEMPORARY PASSAGEWAYS SHALL BE ACCESSIBLE PER 2010 ADA STANDARDS FOR ACCESSIBLE DESIGN CHAPTER 2, SECTIONS 201.3 AND 206.1.
- PUBLIC BEACH AREAS SHALL REMAIN OPEN TO THE MAXIMUM EXTENT POSSIBLE DURING THE CONSTRUCTION PERIOD. PROVIDE AND MAINTAIN SAFE PEDESTRIAN ACCESS TO THE BEACH AREAS THROUGHOUT THE CONSTRUCTION PERIOD.
- UPON COMPLETION OF CONSTRUCTION, THE ENTIRE JOB SITE SHALL BE CLEANED OF ALL RUBBISH AND DEBRIS BY THE CONTRACTOR.
- CONTRACTOR SHALL RESTORE ALL AREAS DISTURBED AS A RESULT OF CONSTRUCTION ACTIVITIES TO EQUAL OR BETTER CONDITION, INCLUDING BUT NOT LIMITED TO VEGETATION, PAVED AREAS, EMBANKMENTS, CURBS, SIGNS, LANDSCAPING, STRUCTURES, UTILITIES, WALKWAYS, FENCES, ETC., UNLESS SPECIFICALLY NOTED OTHERWISE.
- THE CONTRACTOR SHALL PROVIDE ALL INCIDENTAL AND NECESSARY MATERIALS AND WORK TO COMPLETE THE PROJECT.
- THE CONTRACTOR SHALL COORDINATE WITH LOCAL MARITIME AUTHORITIES AND LAHAINA SBH HARBOR MASTER TO ENSURE SAFE NAVIGATION AROUND THE DREDGING SITE.
- ALL DREDGING EQUIPMENT MUST BE INSPECTED DAILY FOR HYDRAULIC AND FUEL LEAKS AND MAINTAINED IN GOOD WORKING CONDITION TO PREVENT SPILLS AND OIL POLLUTION.
- ALL DREDGING ACTIVITIES MUST COMPLY WITH THE CONDITIONS OUTLINED IN THE PERMITS ISSUED BY THE U.S. ARMY CORPS OF ENGINEERS AND THE HAWAII DEPARTMENT OF HEALTH.
- CONTRACTOR SHALL IMPLEMENT AND MAINTAIN Bmps TO MINIMIZE EROSION, SEDIMENTATION, AND POLLUTION DURING ALL PHASES OF CONSTRUCTION IN ACCORDANCE WITH FEDERAL, STATE, AND LOCAL REGULATIONS. Bmps SHALL INCLUDE, BUT ARE NOT LIMITED TO, SILT FENCING, SEDIMENT BASINS, EROSION CONTROL BLANKETS, AND PROPER SITE STABILIZATION MEASURES. ALL Bmps SHALL BE INSPECTED AND MAINTAINED REGULARLY TO ENSURE EFFECTIVE PERFORMANCE. SEE DETAILED BMP NOTES ON THIS SHEET AND SHEET C-3.

GRADING NOTES

- ALL GRADING WORK SHALL BE PERFORMED IN ACCORDANCE WITH THE APPROPRIATE STATE AND LOCAL REGULATORY AGENCIES AND ASSOCIATED PERMIT REQUIREMENTS.
- THE CONTRACTOR SHALL REMOVE ALL SILT AND DEBRIS DEPOSITED OR ACCRETED IN DRAINAGE FACILITIES, ROADWAYS, AND OTHER AREAS RESULTING FROM CONSTRUCTION ACTIVITIES. THE COSTS INCURRED FOR ANY NECESSARY REMEDIAL ACTION SHALL BE PAID BY THE CONTRACTOR.
- THE CONTRACTOR SHALL KEEP THE PROJECT AND SURROUNDING AREAS FREE FROM DUST NUISANCE. THE WORK SHALL BE IN CONFORMANCE WITH THE AIR POLLUTION CONTROL RULES OF THE STATE DEPARTMENT OF HEALTH, HAR 11-60.1, "FUGITIVE DUST."
- ALL GRADING OPERATIONS SHALL BE PERFORMED IN CONFORMANCE WITH THE APPLICABLE PROVISIONS OF THE HAWAII ADMINISTRATIVE RULES (HAR), TITLE 11, CHAPTER 55, "WATER POLLUTION CONTROL," AND CHAPTER 54, "WATER QUALITY STANDARDS," IN ADDITION TO THE EROSION AND SEDIMENTATION CONTROL STANDARDS AND GUIDELINES PROVIDED BY THE DEPARTMENT OF PUBLIC WORKS, MAUI COUNTY.
- NO GRADING WORK SHALL BE PERFORMED ON SATURDAY, SUNDAY, AND HOLIDAYS ANYTIME WITHOUT PRIOR APPROVAL FROM THE CONTRACTING OFFICER, PROVIDED SUCH GRADING WORK IS ALSO IN CONFORMANCE WITH THE COMMUNITY NOISE CONTROL STANDARDS CONTAINED IN THE HAWAII ADMINISTRATIVE RULES, TITLE 11, CHAPTER 46, "COMMUNITY NOISE CONTROL."

PUBLIC HEALTH SAFETY AND CONVENIENCE NOTES

- THE CONTRACTOR SHALL OBSERVE AND COMPLY WITH ALL FEDERAL, STATE, AND LOCAL LAWS REQUIRED FOR THE PROTECTION OF PUBLIC HEALTH, SAFETY, AND ENVIRONMENTAL QUALITY.
- THE CONTRACTOR, AT THEIR OWN EXPENSE, SHALL KEEP THE PROJECT AND ITS SURROUNDING AREAS FREE FROM DUST NUISANCE. THE WORK SHALL BE IN CONFORMANCE WITH THE AIR POLLUTION STANDARDS AND REGULATIONS OF THE STATE DEPARTMENT OF HEALTH. THE COUNTY OF MAUI MAY REQUIRE SUPPLEMENTARY HEALTH, SAFETY, AND/OR ENVIRONMENTAL MEASURES IF REQUIRED, AT THE CONTRACTOR'S EXPENSE.
- THE CONTRACTOR SHALL BE RESPONSIBLE FOR THE CLEANING AND REMOVAL OF ALL SAND, SILT, MUD AND OTHER DEBRIS GENERATED AS A RESULT OF CONSTRUCTION ACTIVITIES, THAT IS DEPOSITED AND/OR ACCUMULATED WITHIN DOWNSTREAM WATERWAYS OR DRAINAGE CONVEYANCES SUCH AS DITCHES AND DRAIN PIPES, AS WELL AS PUBLIC AND PRIVATE ROADWAYS. THE CONTRACTOR AGREES TO REIMBURSE THE COUNTY OF MAUI FOR ALL COSTS EXPENDED IN PERFORMANCE OF ABOVE WORK IF REQUIRED FOR PUBLIC HEALTH AND SAFETY OR OTHERWISE MADE NECESSARY BY NON-PERFORMANCE BY THE CONTRACTOR.
- THE CONTRACTOR SHALL NOT PERFORM ANY CONSTRUCTION OPERATION OR ACTIVITY SO AS TO CAUSE FALLING ROCKS, SOIL, OR OTHER DEBRIS, MANMADE OR NATURAL, IN ANY FORM TO FALL, SLIDE, OR FLOW INTO EXISTING COUNTY DRAINAGE SYSTEMS, OR ADJOINING PROPERTIES, STREETS OR NATURAL WATERCOURSES. SHOULD SUCH VIOLATIONS OCCUR, THE CONTRACTOR MAY BE CITED. IN SUCH CASE, CONTRACTOR SHALL IMMEDIATELY COMMENCE RESPONSE ACTIVITIES AND TAKE ALL REMEDIAL ACTIONS NECESSARY.
- THE CONTRACTOR SHALL ASSUME SOLE RESPONSIBILITY FOR PUBLIC SAFETY IN THE VICINITY OF PROJECT WORK AREAS. THIS REQUIREMENT SHALL APPLY CONTINUOUSLY AND NOT BE LIMITED TO NORMAL WORK HOURS. ALL WORK AREAS SHALL HAVE SUFFICIENT AND SUITABLE SAFETY FENCING AND WARNING SIGNAGE TO ENSURE PUBLIC SAFETY. CONTRACTOR SHALL ALSO PROVIDE, INSTALL, AND MAINTAIN ALL NECESSARY SIGNS, LIGHTS, FLARES, BARRICADES, MARKERS, CONES, AND OTHER PROTECTIVE FACILITIES OR DEVICES AND SHALL TAKE NECESSARY PRECAUTIONS FOR THE PROTECTION, CONVENIENCE, AND SAFETY OF THE PUBLIC.
- THE CONTRACTOR IS DIRECTED TO REVIEW CHAPTER 46, PUBLIC HEALTH REGULATIONS, HAWAII STATE DOH, "COMMUNITY NOISE CONTROL," IN WHICH MAXIMUM PERMISSIBLE NOISE LEVELS HAVE BEEN SET. IF THE CONSTRUCTION WORK REQUIRES A PERMIT FROM THE DIRECTOR OF HEALTH, THE CONTRACTOR SHALL OBTAIN A COPY OF CHAPTER 46 AND BECOME FAMILIAR WITH THE NOISE LEVEL RESTRICTIONS AND THE PROCEDURES FOR OBTAINING A PERMIT FOR THE CONSTRUCTION ACTIVITIES. APPLICATION AND INFORMATION ON VARIANCES ARE AVAILABLE FROM THE ENVIRONMENTAL PROTECTION AND HEALTH SERVICES DIVISION, 99-945 HALAWA VALLEY STREET, HONOLULU, HI 96701 OR BY TELEPHONE AT (808) 586-4400.
- ENSURE ALL WORKERS ARE APPROPRIATELY TRAINED IN REQUIRED SAFETY PROTOCOLS AND PROVIDED WITH APPROPRIATE PERSONAL PROTECTIVE EQUIPMENT (PPE) WHILE ONSITE.
- CONTRACTOR SHALL ESTABLISH A DESIGNATED SAFETY OFFICER ON-SITE TO OVERSEE COMPLIANCE WITH OSHA REGULATIONS AND PROJECT-SPECIFIC SAFETY PLANS.
- CONTRACTOR SHALL IMPLEMENT REASONABLE NOISE REDUCTION MEASURES, SUCH AS USING MUFFLERS ON EQUIPMENT AND SCHEDULING NOISIER ACTIVITIES DURING LESS SENSITIVE TIMES.

ARCHAEOLOGICAL NOTES:

- PURSUANT TO CHAPTER 6E, HAWAII REVISED STATUTES (HRS), IN THE EVENT THAT ANY ARTIFACTS OR HUMAN REMAINS ARE UNCOVERED OR EXPOSED DURING CONSTRUCTION OPERATIONS, THE CONTRACTOR SHALL IMMEDIATELY SUSPEND WORK AND NOTIFY THE MAUI POLICE DEPARTMENT AND STATE DLNR, HISTORIC PRESERVATION DIVISION AT (808) 692-8015.
- IN THE EVENT THAT AN ARCHAEOLOGICAL OR HISTORIC STRUCTURE WITHIN THE WORK AREA IS INADVERTENTLY DAMAGED DURING CONSTRUCTION, CEASE WORK IN THE VICINITY OF THE SITE AND NOTIFY THE ENGINEER AND THE STATE HISTORIC PRESERVATION DIVISION (SHPD) OF THE DAMAGE. SHPD WILL DETERMINE THE APPROPRIATE MITIGATION MEASURES.
- IN THE EVENT THAT A PREVIOUSLY UNKNOWN ARCHAEOLOGICAL FEATURE IS EXPOSED BY CONSTRUCTION, CEASE WORK IN THE VICINITY OF THE FIND AND NOTIFY THE ENGINEER AND SHPD OF THE NEW DISCOVERY. SHPD WILL DETERMINE THE APPROPRIATE RESPONSE OR MITIGATION MEASURES.
- IN THE EVENT THAT PREVIOUSLY UNKNOWN HUMAN REMAINS ARE EXPOSED BY CONSTRUCTION, CEASE ALL WORK IN THE AREA OF THE REMAINS, AND PROTECT THE AREA WITH A REASONABLY APPROPRIATE MATERIAL. CONTRACTOR SHALL IMMEDIATELY NOTIFY THE ENGINEER AND SHPD AT 808-692-8015.
- IF HUMAN REMAINS ARE DISCOVERED, HAR TITLE 13, SUBTITLE 13, CHAPTER 300 STATES THAT FURTHER DISTURBANCES AND ACTIVITIES SHALL CEASE IN ANY AREA OR NEARBY AREA SUSPECTED TO OVERLIE REMAINS, AND THE STATE HISTORIC PRESERVATION DIVISION AND THE POLICE DEPARTMENT WILL BE CONTACTED. THE APPROPRIATE PROCESS WOULD THEN PROCEED IN CONFORMANCE WITH HAR 13-300 SUBCHAPTER 4, "PROCEDURES FOR PROPER TREATMENT OF BURIAL SITES AND HUMAN SKELETAL REMAINS."
- IF ANY LAVA TUBE OR CORAL CAVERN IS UNCOVERED DURING EARTHWORK OPERATIONS, THE CONTRACTOR SHALL CEASE ALL GROUND WORK IN THE AREA AND IMMEDIATELY NOTIFY THE ENGINEER. WITH OR WITHOUT THE HELP OF THE ARCHAEOLOGICAL MONITOR, THE ENGINEER WILL ASSESS THE SITUATION. IF THE ENGINEER HAS ANY DOUBTS AS TO THE EXTENT AND/OR SIGNIFICANCE OF THE DISCOVERY, THE ENGINEER WILL CONTACT THE APPROPRIATE REGULATORY AGENCY (E.G., STATE HISTORIC PRESERVATION DIVISION).

MISCELLANEOUS:

- AN ENVIRONMENTAL PROTECTION PLAN AND A BEST MANAGEMENT PRACTICES PLAN SHALL BE SUBMITTED TO THE ENGINEER NO LATER THAN 2 WEEKS BEFORE COMMENCEMENT OF WORK.

BEST MANAGEMENT PRACTICES (BMP) NOTES:

- AT THEIR OWN EXPENSE, THE CONTRACTOR SHALL KEEP THE PROJECT AREA AND SURROUNDING VICINITY FREE FROM DUST NUISANCE. THE WORK SHALL BE PERFORMED IN ACCORDANCE WITH AIR POLLUTION CONTROL STANDARDS PROVIDED IN HAWAII ADMINISTRATIVE RULES: CHAPTER 11-60, "AIR POLLUTION CONTROL."
- CONTRACTOR SHALL ENSURE THAT NECESSARY MEASURES TO CONTROL EROSION RUNOFF AND OTHER POLLUTANTS ARE INSTALLED IN PLACE PRIOR TO COMMENCEMENT OF ANY CONSTRUCTION ACTIVITIES. THESE MEASURES SHALL BE PROPERLY CONSTRUCTED AND MAINTAINED THROUGHOUT THE CONSTRUCTION PERIOD.
- CONTRACTOR SHALL OBSERVE AND COMPLY WITH THE STATE OF HAWAII DOH REGULATIONS REGARDING STORMWATER DISCHARGE.
- ALL EROSION CONTROL MEASURES SHALL BE CHECKED AND REPAIRED AS NECESSARY, AT A MINIMUM, WEEKLY IN DRY PERIODS AND WITHIN 24 HOURS AFTER ANY RAINFALL OF 0.5 INCHES OR GREATER WITHIN A 24-HR PERIOD. DURING AN EVENT OF ABOVE NORMAL RAINFALL, THE CONTRACTOR SHALL REMOVE THE SEDIMENT AND DRAIN INLET FILTER AND REPLACE AFTER THE EVENT HAS PASSED. THE CONTRACTOR SHALL MAINTAIN RECORDS OF ALL CHECKS AND REPAIRS AND A COPY SHALL BE MADE AVAILABLE UPON REQUEST AT THE CONSTRUCTION FIELD OFFICE.
- GOOD CONSTRUCTION HOUSEKEEPING PRACTICES SHALL BE UTILIZED TO ENSURE PROTECTION OF ROADWAYS FROM TRACKING AND OTHER WASTE PROPAGATION FROM CONSTRUCTION SITE MUD, DIRT, AND DEBRIS.
- THE CONTRACTOR SHALL FURNISH, PROVIDE AND INSTALL EROSION CONTROL MEASURES FOR THEIR CONSTRUCTION, STAGING, STOCKPILING, AND STORAGE AREAS AND SHALL INSPECT AND MONITOR THEIR CONSTRUCTION, STAGING, STOCKPILING, AND STORAGE AREAS TO ENSURE THAT NO STORMWATER-RELATED DISCHARGES ARE EMITTED. IF SUCH SOURCES ARE IDENTIFIED, CONTRACTOR SHALL PROVIDE IMMEDIATE MITIGATIVE MEASURES.
- CONTRACTOR SHALL ENSURE THAT SEDIMENT-LADEN RUNOFF DOES NOT LEAVE THE SITE.
- THE CONTRACTOR SHALL DISPOSE OF WASTE VEGETATION, EXPENDABLE EQUIPMENT, WASTE MATERIALS, AND PETROLEUM-BASED PRODUCTS AT AN APPROPRIATE OFF-SITE RECEPTION FACILITY.
- AT THE END OF CONSTRUCTION, THE EXISTING DRAIN SYSTEM SURROUNDING THE PROJECT SITE SHALL BE INSPECTED AND ANY ACCUMULATED SEDIMENT AND DEBRIS FOUND SHALL BE REMOVED. INTENTIONAL OR UNINTENTIONAL FLUSHING OF ANY CONTAMINANTS INTO THE DRAINAGE SYSTEM IS STRICTLY PROHIBITED.

ABBREVIATIONS:

(°)	DEGREE, ANGLE
(')	MINUTE, ANGLE
(")	SECOND, ANGLE
APPROX.	APPROXIMATELY
BL, ☒	BASELINE
BM	BENCHMARK
BMP	BEST MANAGEMENT PRACTICES
CY	CUBIC YARDS
DOH	(STATE OF HAWAII) DEPARTMENT OF HEALTH
DLNR	(STATE OF HAWAII) DEPARTMENT OF LAND AND NATURAL RESOURCES
(E), EXIST	EXISTING
EB	END BASELINE
EG	EXISTING GROUND
EL, ELEV.	ELEVATION
FT, (')	FEET
IN, (")	INCH
LBS	POUNDS (WEIGHT)
MAX	MAXIMUM
MLLW	MEAN LOWER LOW WATER TIDAL DATUM
MSL	MEAN SEA LEVEL TIDAL DATUM
NAD83	NORTH AMERICAN DATUM OF 1983
MIN	MINIMUM
(N)	NEW
NTS	NOT TO SCALE
OSHA	OCCUPATIONAL SAFETY AND HEALTH ADMINISTRATION
PA11	NATIONAL SPATIAL REFERENCE SYSTEM PA11
SB	START BASELINE
SBH	SMALL BOAT HARBOR
SHPD	(HAWAII) STATE HISTORIC PRESERVATION DIVISION
SHT(S)	SHEET(S)
STA.	STATION
TMK	TAX MAP KEY
TYP.	TYPICAL
V:H	VERTICAL TO HORIZONTAL (SLOPE)

REVISION NO.	SYM.	DESCRIPTION	SHT./OF	DATE	APPROVED
STATE OF HAWAII DEPARTMENT OF LAND AND NATURAL RESOURCES ENGINEERING DIVISION					
MALA BOAT RAMP MAINTENANCE DREDGING					
GENERAL NOTES & ABBREVIATIONS					
DESIGNED: CCG			SUBMITTED: NOT SUBMITTED		
DRAWN: CCG, GW			DATE: 11 September 2024		
CHECKED: DRAFT			SCALE: N/A		
APPROVED:			DRAWING NO.		
SIGNATURE			DATE		
CHIEF ENGINEER			DATE		

60% DRAFT PLANS

G-1

/Users/goodster/Library/CloudStorage/OneDrive-SanEwEngineering/Lahaina & Mala Dredge/DWG/60_PCT/Mala/WORKING REVISIONS/20240909/2 - G-1 - GENERAL NOTES.dwg, Thu Sep 12 14:53:06 2024
 1:1, *** NOT FOR CONSTRUCTION ***

PROJECT CONTROL NETWORK

Scale: 1" = 20'

SURVEY CONTROL NOTES

- SEE SHT C-2 FOR DESCRIPTIONS OF PROJECT AREAS AND WORK TASKS.
- ALL ELEVATIONS SHOWN ARE REFERENCED TO MEAN LOWER LOW WATER (MLLW) FROM NGS BENCHMARK DR4488 HOLDING TIDAL STATION 161 5680 C, KAHULUI HARBOR.
- ALL HORIZONTAL COORDINATES ARE REFERENCED TO HAWAII STATE PLANE, ZONE 2, US SURVEY FEET, NAD83(PA11) AS EASTINGS (X-COORDINATE) AND NORTHINGS (Y-COORDINATE).
- AZIMUTHS ARE SHOWN IN DEGREES/MINUTES/SECONDS CLOCKWISE FROM TRUE SOUTH.
- AERIAL PHOTOGRAPH POSITIONS AND SHORELINE FEATURES MAPPED FROM THE AERIAL IMAGE ARE APPROXIMATE.
- TOPOGRAPHIC SURVEY COMPLETED BY AILANA SURVEYING AND GEOMATICS, LLC., 02 JUNE 2023.
- BATHYMETRIC SURVEY COMPLETED BY SEA ENGINEERING, 22 MAY 2023.
- CONSTRUCTION EASEMENT FOLLOWS OUTER BOUNDARIES OF COMBINED TMK PARCELS (2)4-5-005:001 AND (2)4-5-004:011, EXCEPT WHERE IT IS TRIMMED OR EXTENDED BY THE LIMITS CREATED FROM THE BOUNDARY DEFINED BY THE FOLLOWING COORDINATES, AND AS SHOWN IN THE MALA BOAT RAMP VICINITY MAP BELOW (ALL COORDINATES IN FEET):

EASTING	NORTHING	ALL WORK, EQUIPMENT AND DREDGED MATERIAL STOCKPILE SHALL BE CONTAINED WITHIN THE CONSTRUCTION EASEMENT BOUNDARY, AS SHOWN ON THIS SHEET AND ON SHT C-3. STOCKPILE AREA & ENVIRONMENTAL CONTROLS. DREDGE MATERIAL DEWATERING MAY TAKE PLACE WITHIN THE LIMITS OF THE CONTRACTOR STOCKPILE AREA. USE OF STOCKPILE AREA SHALL BE COORDINATED WITH AND APPROVED BY THE LAHAINA SBH HARBOR AGENT OR THEIR REPRESENTATIVE.
1,633,670.72	200,506.90	
1,633,695.82	200,528.33	
1,633,741.65	200,537.24	
1,633,746.63	200,549.98	
1,633,746.63	200,809.38	
1,633,346.63	200,809.38	
1,633,346.63	200,617.17	
1,633,595.56	200,330.16	
1,633,551.51	200,163.28	

- THE DREDGE LIMITS BOUNDARY AND BASELINES ARE DEFINED BY THE FOLLOWING TABLES OF COORDINATES, WHICH ARE PROVIDED BELOW IN THE CORRECT ORDER OF DELINEATION:

DREDGE LIMITS BOUNDARY POINT TABLE (FT)

POINT #	EASTING	NORTHING
1	1,633,532.81	200,485.57
3	1,633,558.95	200,507.25
4	1,633,516.36	200,556.29
5A	1,633,508.99	200,565.06
5B	1,633,509.16	200,582.49
6	1,633,507.31	200,604.04
7	1,633,548.87	200,609.43
8	1,633,566.91	200,594.66
17	1,633,605.10	200,539.26
18	1,633,650.08	200,561.45
9	1,633,633.85	200,598.57
10	1,633,664.13	200,665.51
12	1,633,494.58	200,759.38
13	1,633,488.25	200,684.96
14	1,633,458.27	200,596.64
15	1,633,491.85	200,535.33

DREDGE AREA BASELINE POINT TABLE (FT)

POINT #	EASTING	NORTHING
2	1,633,545.87	200,496.41
16	1,633,472.84	200,581.32
11	1,633,553.39	200,726.83

BARGE OFFLOAD BASELINE POINT TABLE (FT)

POINT #	EASTING	NORTHING
19	1,633,681.78	200,450.77
20	1,633,588.14	200,627.50

- CONTRACTOR MAY MOOR/ANCHOR FLOATING EQUIPMENT IN THE HARBOR DURING NON-WORKING HOURS, PROVIDED HARBOR USE IS NOT IMPEDED, AND SHALL COORDINATES SUCH USE WITH THE HARBOR MASTER.
- CONTRACTOR SHALL VERIFY HORIZONTAL AND VERTICAL CONTROLS IN THE FIELD. ANY DISCREPANCIES FOUND SHALL BE REPORTED TO THE ENGINEER.
- LOCATION OF THE CONSTRUCTION EASEMENT RELATIVE TO EXISTING TMK PARCEL BOUNDARIES AND THE MALA BOAT RAMP VICINITY IS SHOWN IN THE VICINITY MAP BELOW:

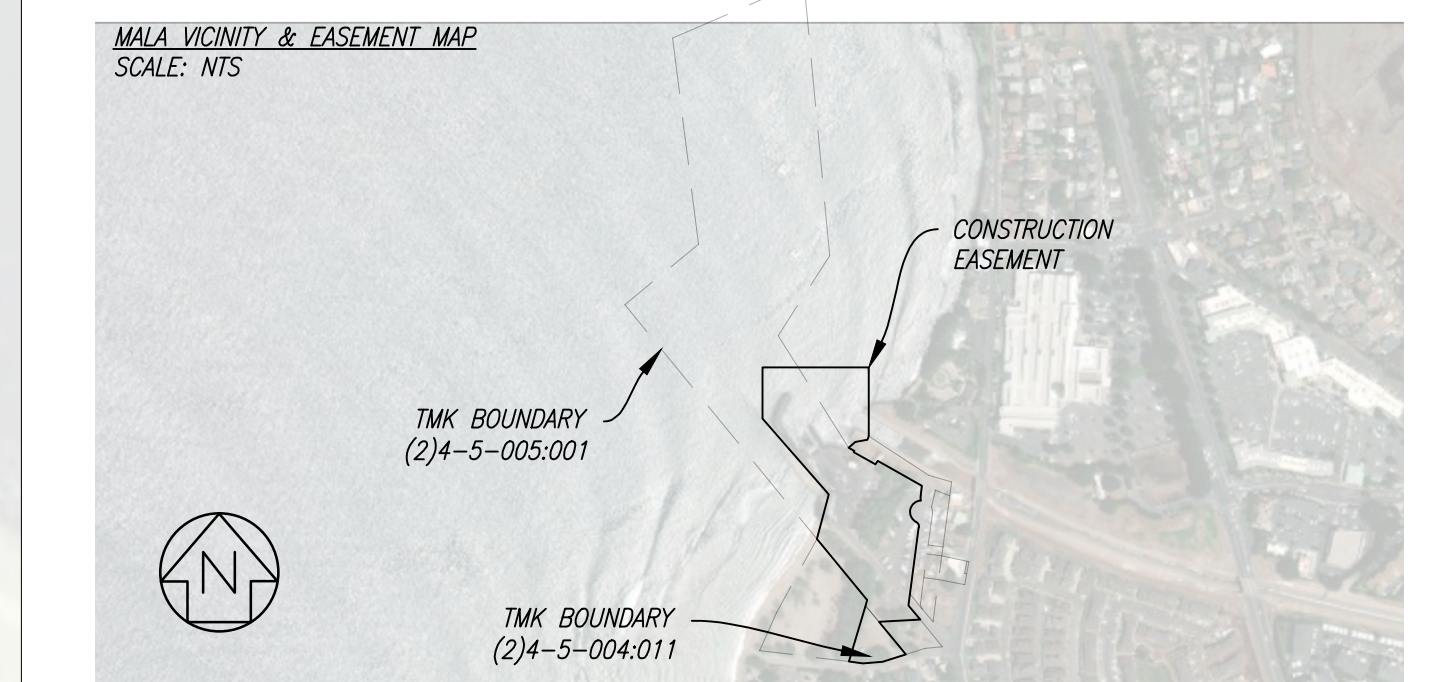

REVISION NO.	SYM.	DESCRIPTION	SHT. OF	DATE	APPROVED
STATE OF HAWAII DEPARTMENT OF LAND AND NATURAL RESOURCES ENGINEERING DIVISION					
MALA BOAT RAMP MAINTENANCE DREDGING					
PROJECT CONTROL NETWORK					
DESIGNED:	CCG	SUBMITTED:	NOT SUBMITTED		
DRAWN:	CCG, GW	DATE:	11 September 2024		
CHECKED:	DRAFT	SCALE:	AS SHOWN		
APPROVED:		DATE:			DRAWING NO.
SIGNATURE	DATE	CHIEF ENGINEER	DATE		C-1

60% DRAFT PLANS

/Users/goodster/Library/CloudStorage/OneDrive-SanEngineering/Lahaina & Mala Dredge/DWG/EO_PCT/Mala/WORKING REVISIONS/20240909/3 - C-1 - CONTROL POINTS UPDATED.dwg, Thu Sep 12 14:14:11, 1:1, *** NOT FOR CONSTRUCTION ***

LEGEND:

- DREDGE LIMITS BOUNDARY
- CONSTRUCTION EASEMENT BOUNDARY
- RIPRAP STRUCTURE (REVETMENT/BREAKWATER)
- PROJECT BENCHMARK LOCATIONS

SCALE: 1"=20'

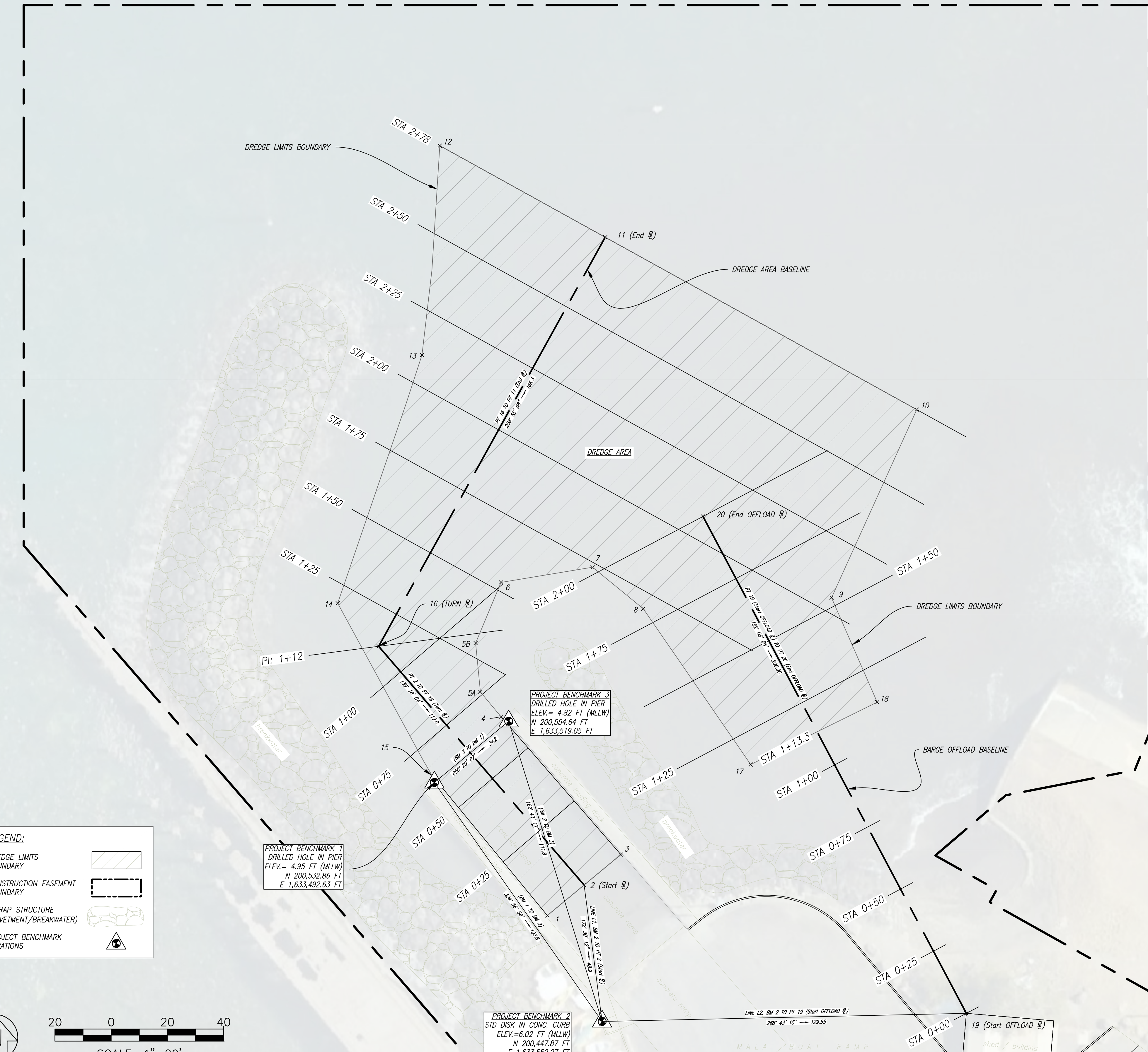

PROJECT BENCHMARK 1
DRILLED HOLE IN PIER
ELEV.= 4.95 FT (MLLW)
N 200,532.86 FT
E 1,633,492.63 FT

PROJECT BENCHMARK 3
DRILLED HOLE IN PIER
ELEV.= 4.82 FT (MLLW)
N 200,554.64 FT
E 1,633,519.05 FT

PROJECT BENCHMARK 2
STD DISK IN CONC. CURB
ELEV.= 6.02 FT (MLLW)
N 200,447.87 FT
E 1,633,552.27 FT

DREDGING SITE PLAN

Scale: 1" = 20'

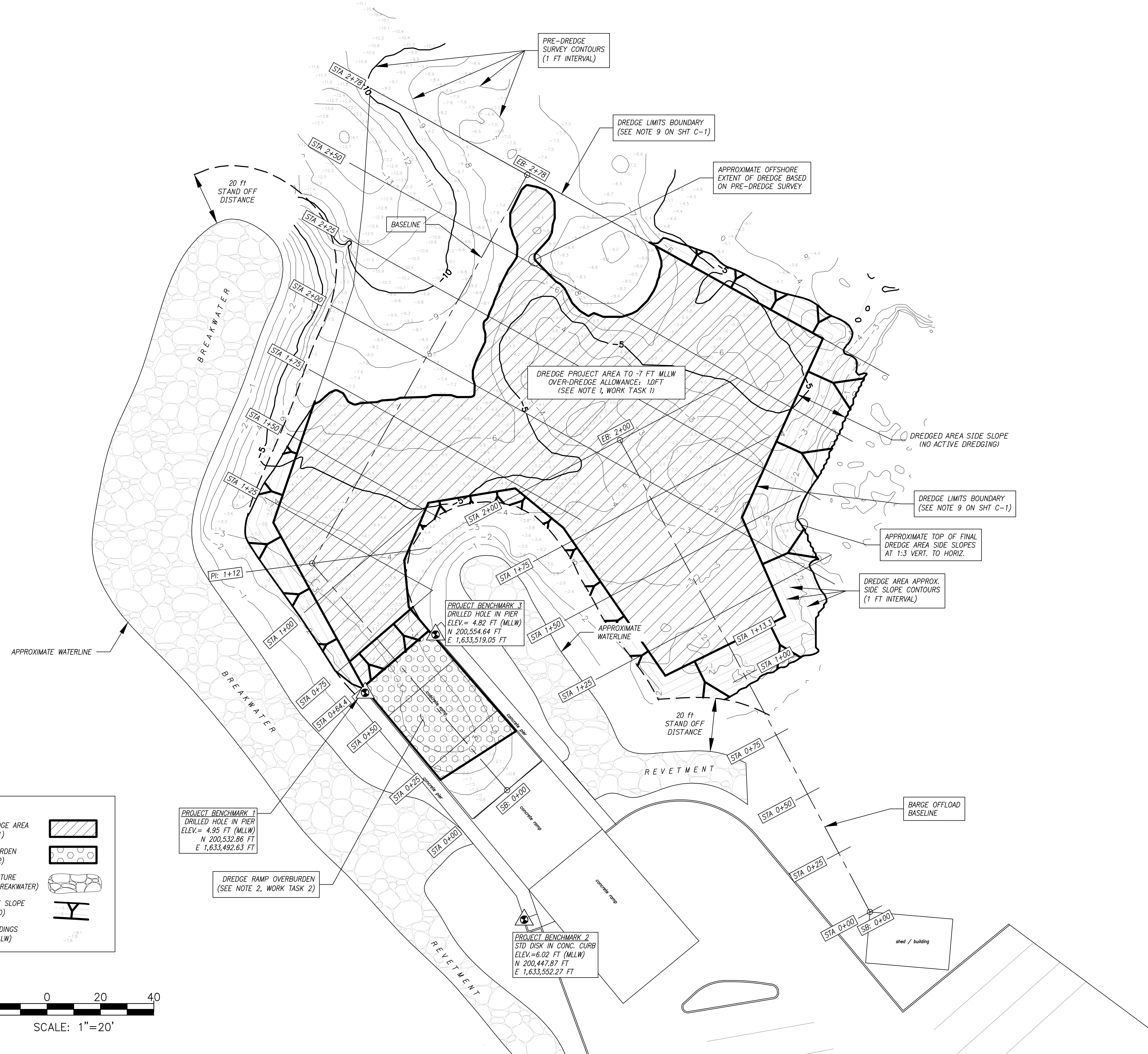

LEGEND:

PRIMARY DREDGE AREA (WORK TASK 1)	
RAMP OVERBURDEN (WORK TASK 2)	
RIPRAP STRUCTURE (REVTMENT/BREAKWATER)	
DREDGED SIDE SLOPE (APPROXIMATED)	
SURVEY SOUNDINGS (FT BELOW MLLW)	

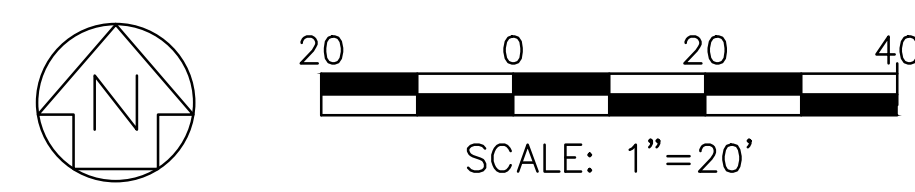

- CONSTRUCTION NOTES:**
- WORK TASK 1: THE PRIMARY DREDGE AREA EXTENDS FROM OFFSHORE END OF CONCRETE BOAT RAMP NEAR BASELINE STATION 00+64.4 TO THE END OF THE BASELINE AT STATION 02+78, AND ALONG THE BARGE OFFLOAD BASELINE FROM STATION 01+13.3 TO STATION 02+00. DREDGE A SLOPING TRANSITION FOR THE LIMITED AREA BETWEEN END OF CONCRETE BOAT RAMP (NEAR BASELINE STATION 0+64.4) AND START OF FULL PROJECT DEPTH (-7 FT MLLW) AT BASELINE STATION 00+75, NOT EXCEEDING A MAXIMUM SLOPE OF 1:3 (V:H). SLOPE SHALL START AT EXISTING ELEVATION OF BOTTOM END OF RAMP AND PROCEED DOWN TO PROJECT DEPTH AT (-7 FT MLLW). BETWEEN BASELINE STATION 00+75 AND STATION 02+78, AND BETWEEN BARGE OFFLOAD BASELINE STATION 01+13.3 AND STATION 02+00, DREDGE TO A DEPTH OF (-7 FT MLLW) WITHIN THE GIVEN LIMITS AS INDICATED BY THESE PLANS. THE CONTRACTOR MAY DEWATER AND STOCKPILE DREDGED MATERIAL IN THE CONTRACTOR WORK, STORAGE AND STOCKPILE AREA AS SHOWN ON SHEET C-3. DIAGONAL HATCHING ON THIS SHEET INDICATES THE AREA DESIGNATED FOR WORK TASK 1. APPROXIMATE LOCATIONS AND EXTENTS OF SIDE SLOPES INDICATED BY SLOPE SYMBOLS DRAWN AROUND PERIMETER OF DREDGE LIMITS.
 - WORK TASK 2: DREDGE EXISTING OVERBURDEN OF SAND/SILT/GRAVEL OVER EXISTING CONCRETE BOAT RAMP AS NECESSARY. CONTRACTOR SHALL TAKE APPROPRIATE MEASURES AND INSTITUTE NECESSARY CONTROLS TO AVOID DAMAGE TO THE BOAT RAMP DURING CONSTRUCTION. ANY DAMAGE TO THE RAMP, PIERS, LOADING DOCKS, OR BREAKWATERS INCURRED FROM DREDGING OR RELATED CONSTRUCTION ACTIVITIES SHALL BE REPAIRED BY THE CONTRACTOR AT THEIR OWN EXPENSE. HEXAGONAL HATCHING ON THIS SHEET INDICATES THE AREA DESIGNATED FOR WORK TASK 2.
 - THIS PROJECT CONSISTS OF MAINTENANCE DREDGING ONLY. CONTRACTOR SHALL NOT DREDGE INTO PREVIOUSLY UNDISTURBED AREAS OR HARD BOTTOM. MAINTENANCE DREDGING SHALL INCLUDE THE REMOVAL OF LOOSE MATERIALS. LOOSE MATERIALS ARE DEFINED IN THE CONTRACT SPECIFICATION ENTITLED "DREDGING."
 - AN OVER-DREDGE ALLOWANCE OF 1 FT, TO AN ELEVATION OF -8 FT MLLW, IS AUTHORIZED FOR WORK TASK 1, EXCLUDING SIDE SLOPE AREAS, AND THE ENTIRE AREA DESIGNATED FOR WORK TASK 2.
 - VOLUME OF AVAILABLE DREDGE MATERIAL BASED ON THE GIVEN LIMITS IS APPROXIMATELY 2,620 CY TO THE STANDARD DREDGE TEMPLATE, AS SHOWN IN THESE PLANS (WORK TASK 1 AND 2 COMBINED). A TOTAL VOLUME OF APPROXIMATELY 3,350 CY IS AVAILABLE TO THE STANDARD DREDGE TEMPLATE PLUS ALLOWABLE 1 FT OVER-DREDGE. CALCULATED VOLUME ESTIMATES ARE FOR THE ENTIRE DREDGE PRISM AND INCLUDE AVAILABLE MATERIAL OVER THE SIDE SLOPES.
 - MAINTENANCE DREDGING SHALL BE PERFORMED BY MECHANICAL DREDGING METHODS ONLY. HYDRAULIC DREDGING METHODS OR BLASTING ARE NOT AUTHORIZED FOR THIS PROJECT.
 - THE CONSTRUCTION OF A CAUSEWAY FOR THE PURPOSE OF DREDGING IS NOT AUTHORIZED.
 - CONTRACTOR SHALL DREDGE TO THE PROVIDED DREDGE LIMITS BOUNDARY, AS DEFINED BY THE 'DREDGE LIMITS POINT TABLE' PROVIDED IN NOTE 9 ON SHEET C-1. DREDGE LIMITS DELINEATED BY THIS BOUNDARY REPRESENT THE TOES OF THE DREDGE AREAS. SIDE SLOPES, WHERE PRESENT, ARE APPROXIMATED ON THIS SHEET FOR REFERENCE ONLY, AND ARE BASED ON THE INTERPOLATED INTERSECTION OF THE DREDGE PRISM AND THE PRE-DREDGE SURVEY DATA DESCRIBED BELOW UNDER 'HYDROGRAPHIC SURVEY NOTES' ON THIS SHEET.
 - DESIGN SIDE SLOPES ARE 1V:3H (TYPICAL). THE CONTRACTOR SHALL CONFINE ACTIVE DREDGING TO THE DREDGE LIMITS BOUNDARY LINE (SEE NOTE 10 ON THIS SHEET), AND SHALL DREDGE TO THE BOUNDARY LIMITS UNTIL THE COLLAPSING SIDE SLOPE HAS STABILIZED AND THE PROJECT DEPTH IS MAINTAINED AT THE GIVEN DREDGE LIMITS. IF DREDGE MATERIAL COLLAPSES INTO THE PROJECT AREA FROM SHALLOWER DEPTHS DUE TO SIDE SLOPES EXCEEDING THE NATURAL ANGLE OF REPOSE, CONTRACTOR SHALL CONTINUE DREDGING UNTIL THE SIDE SLOPE HAS STABILIZED AND THE PROJECT DEPTH IS MAINTAINED AT THE PROJECT LIMITS.
 - AT NO TIME SHALL THE CONTRACTOR DREDGE CLOSER THAN 20 FEET HORIZONTALLY TO THE WATERLINE (ELEVATION 0.0' MLLW) ALONG THE BREAKWATER OR SHORELINE REVTMENTS, OR DISTURB THE FOUNDATION TOE STONES OF THE BREAKWATER OR SHORELINE REVTMENTS. IF A DISCREPANCY IS FOUND BETWEEN THIS REQUIREMENT AND THE LOCATION OF THE DREDGE PROJECT LIMITS, THE CONTRACTOR SHALL NOTIFY THE ENGINEER AND THE CONTRACTING OFFICER'S REPRESENTATIVE IMMEDIATELY.
 - LOCATION AND ELEVATION OF BOTTOM END OF THE CONCRETE BOAT RAMP IS UNVERIFIED. THE CONTRACTOR SHALL BE RESPONSIBLE FOR IDENTIFYING THE LIMITS AND EXTENTS OF THE BURIED SECTION OF RAMP FOR AWARENESS AND AVOIDANCE DURING CONSTRUCTION ACTIVITIES. CONTRACTOR SHALL EXERCISE CAUTION AND INSTITUTE APPROPRIATE CONTROLS WHILE DREDGING IN THE RAMP VICINITY.
 - WHERE THERE IS A DISCREPANCY BETWEEN THE 20' BREAKWATER STAND-OFF DISTANCE AND THE GIVEN DREDGING LIMITS BOUNDARY, THE CONTRACTOR SHALL DREDGE TO WHICHEVER BOUNDARY IS OBTAINED FIRST.
 - DREDGED MATERIAL THAT IS DEWATERED SHALL BE DEWATERED BY PERCOLATION INTO THE GROUND OR BY ATMOSPHERIC EVAPORATION. RETURN WATER FROM DREDGED MATERIAL SHALL NOT BE ALLOWED TO DRAIN INTO THE HARBOR OR COASTAL WATERS. DREDGED MATERIAL SHALL NOT BE STOCKPILED IN THE WATER.
 - CONTRACTOR SHALL PROVIDE TWO WEEKS NOTICE TO THE LAHAINA SBH HARBOR AGENT OR THEIR OFFICIAL REPRESENTATIVE PRIOR TO START OF DREDGING.
 - USE OF HARBOR FACILITIES, INCLUDING RAMPS AND LOADING DOCKS, SHALL BE COORDINATED WITH AND APPROVED BY THE LAHAINA SBH HARBOR AGENT. CONTRACTOR SHALL STAY WITHIN LOAD LIMITS OF ALL EXISTING FACILITIES, INCLUDING RAMP AND LOADING DOCKS. ANY DAMAGE TO EXISTING FACILITIES RESULTING FROM CONTRACTOR OPERATIONS SHALL BE REPAIRED AT CONTRACTOR'S EXPENSE.
 - CONTRACTOR SHALL LOCATE AND VERIFY ALL UTILITIES WITHIN THE PROJECT SITE PRIOR TO START OF WORK.
- HYDROGRAPHIC SURVEY NOTES:**
- HYDROGRAPHIC SURVEY COMPLETED 03 MAY 2023 BY SEA ENGINEERING. BASEMAP FEATURES ARE APPROXIMATE.
 - SOUNDINGS ARE SHOWN AS ELEVATIONS IN FEET AND TENTHS REFERENCED TO THE MLLW DATUM PUBLISHED FOR KAHULUI HARBOR. SEE SURVEY CONTROL NOTES, SHEET C-1.
 - CONTOUR INTERVAL IS 1 FT, HIGHLIGHTED WITH INDEX CONTOURS EVERY 5 FT.

REVISION NO.	SYM.	DESCRIPTION	SHT./OF	DATE	APPROVED
STATE OF HAWAII DEPARTMENT OF LAND AND NATURAL RESOURCES ENGINEERING DIVISION MALA BOAT RAMP MAINTENANCE DREDGING DREDGING SITE PLAN					
DESIGNED: CCG			SUBMITTED: NOT SUBMITTED		
DRAWN: CCG, GW			DATE: 11 September 2024		
CHECKED: DRAFT			SCALE: AS SHOWN		
APPROVED: _____			DRAWING NO. _____		
SIGNATURE: _____			DATE: _____		
CHIEF ENGINEER			DATE		

60% DRAFT PLANS

C-2

I:\Users\goodster\Library\CloudStorage\OneDrive\SeaEng\Engineering\LaHaina & Mala Dredge\DWG\60_PCT\Mala\WORKING REVISIONS\20240909\4 - C-2 - OVERALL PROJECT PLAN UPDATED.dwg, Thu 9/11/24, 1:1, *** NOT FOR CONSTRUCTION ***

/Users/goodster/Library/CloudStorage/OneDrive-San_Enginering/Lahaina & Mala Dredge/DWG/60_PCT/Mala/WORKING REVISIONS/20240909/5 - C-3 - OFFLOADING AND STOCKPILE AREAS.dwg, Thu 11/14/24, 1:11, *** NOT FOR CONSTRUCTION ***



TEMPORARY STOCKPILE AREA AND HAUL ROUTE PLAN
Scale: 1" = 60'

DRAFT PLANS - NOT FOR CONSTRUCTION

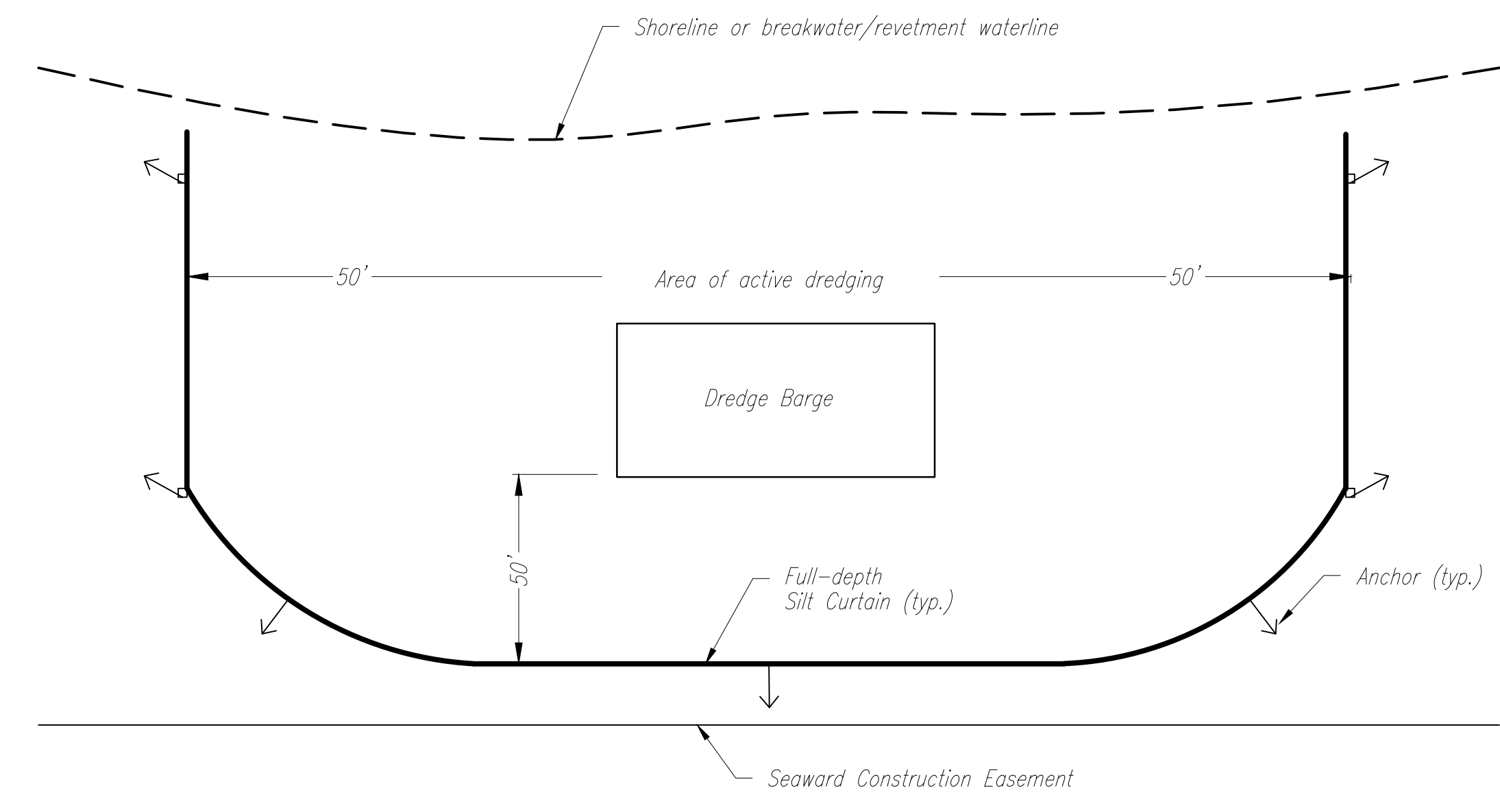

SILT CURTAIN DEPLOYMENT DETAIL FOR ACTIVE DREDGING AREA(S)
Scale: NTS

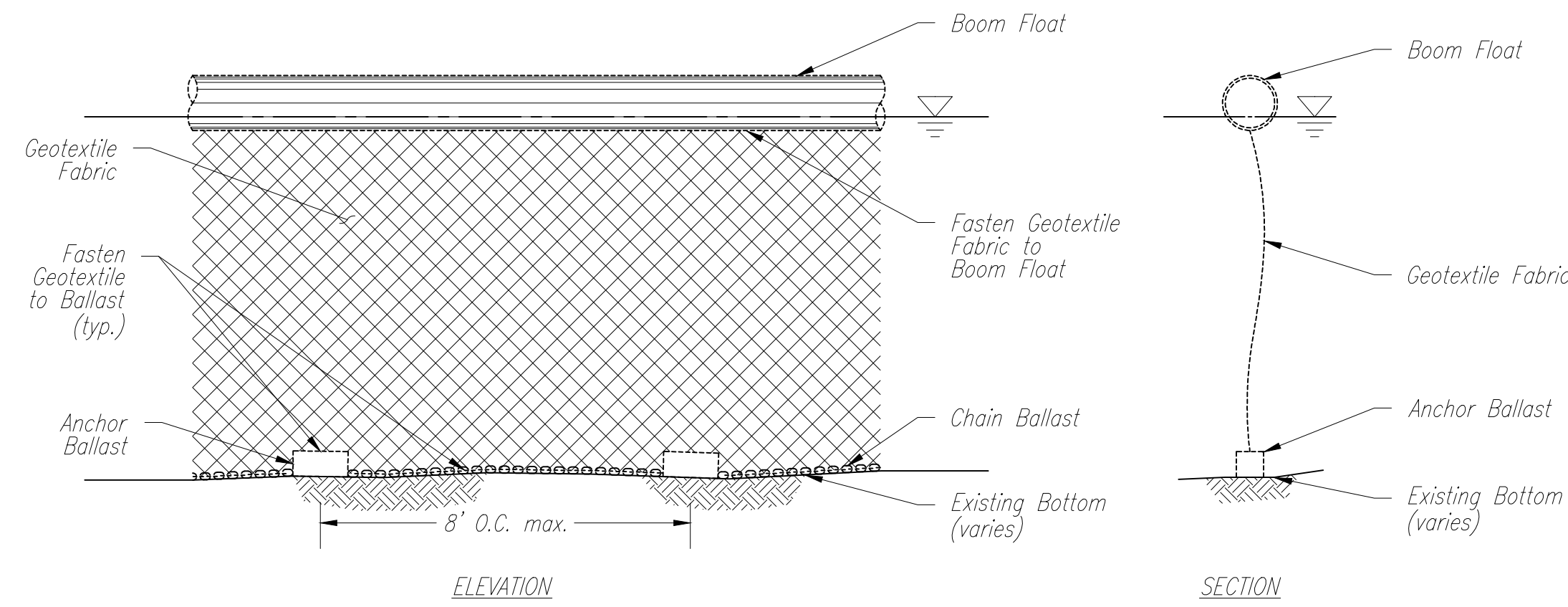

TURBIDITY CONTAINMENT DEVICE DETAIL
Scale: NTS

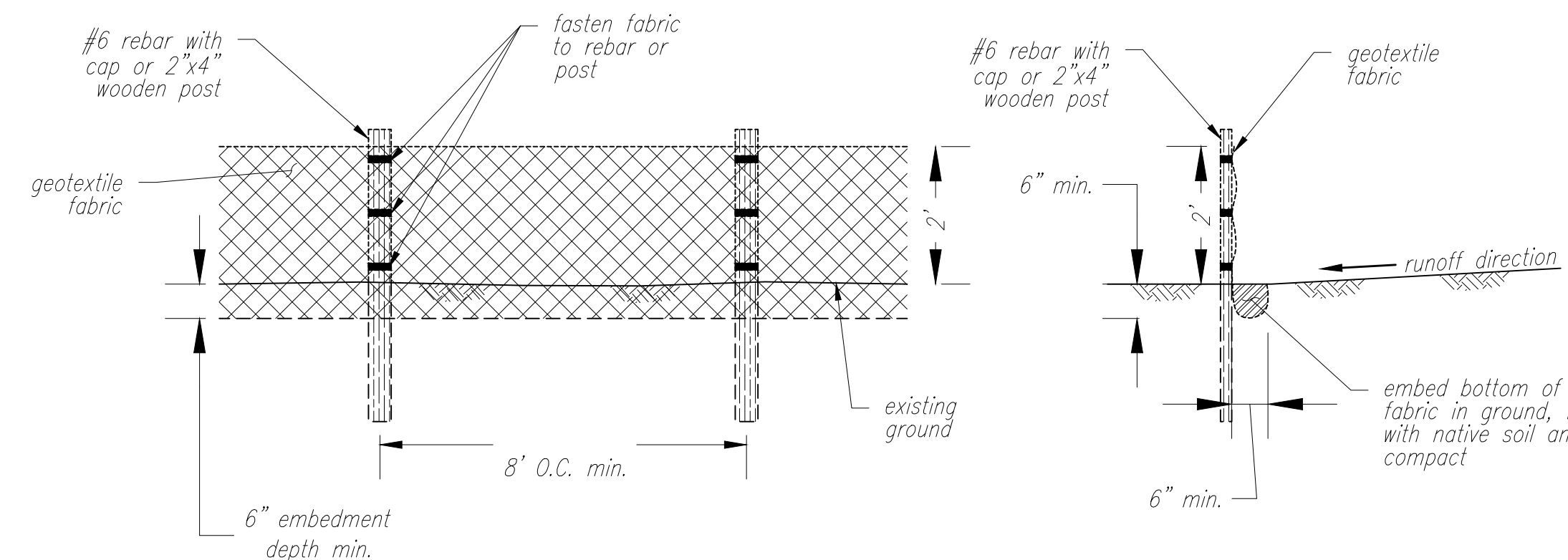

SILT FENCE DETAIL
Scale: NTS

- ENVIRONMENTAL NOTES:**
- DREDGE SPOILS SHALL BE TRANSPORTED TO THE TEMPORARY STOCKPILE AREA FOR DEWATERING AND TEMPORARY STORAGE, UNTIL SUCH MATERIALS ARE TRANSPORTED TO THE FINAL RECEPTION AND DISPOSAL SITE. THE TEMPORARY STOCKPILE AREA IS LOCATED AT TMK (2)4-5-004:011, AS SHOWN ON THIS SHEET.
 - THE CONTRACTOR SHALL USE THE DESIGNATED HAUL ROUTE, AS SHOWN ON THIS SHEET, TO TRANSPORT DREDGED SPOILS FROM BARGE TO TEMPORARY STOCKPILE LOCATION, AS SHOWN IN THE TEMPORARY STOCKPILE AREA AND HAUL ROUTE PLAN ON THIS SHEET.
 - DREDGED MATERIAL SHALL BE DEWATERED BY PERCOLATION INTO THE GROUND OR BY EVAPORATION. DREDGED MATERIAL RETURN WATER SHALL NOT BE ALLOWED TO DRAIN INTO THE HARBOR OR COASTAL WATERS. DREDGED MATERIAL SHALL NOT BE STOCKPILED IN THE WATER.
 - SILT FENCING SHALL BE INSTALLED AROUND THE ENTIRE STOCKPILE AREA PERIMETER, AS SHOWN IN THE TEMPORARY STOCKPILE AREA AND HAUL ROUTE PLAN ON THIS SHEET.

- BEST MANAGEMENT PRACTICES (BMP) NOTES:**
- TURBIDITY CONTAINMENT DEVICES (SILT CURTAINS) SHALL BE DEPLOYED IN THE WATER AROUND AREAS OF ACTIVE DREDGING, EXTENDING 50 FEET (MIN) FROM BOTH SIDES OF BARGE AND ACTIVE DREDGING, AS SHOWN IN THE SILT CURTAIN DEPLOYMENT DETAIL ON THIS SHEET. WHERE EXISTING HARBOR STRUCTURES AND/OR SHORELINE SHAPE LIMIT THIS DISTANCE, THE CONTRACTOR SHALL MAKE REASONABLE EFFORTS TO APPROXIMATE THIS CONFIGURATION.
 - TURBIDITY CONTAINMENT DEVICES (SILT CURTAINS) SHALL BE OF SUFFICIENT DESIGN, STRENGTH, AND SUITABILITY FOR THEIR INTENDED APPLICATION IN THE OCEAN ENVIRONMENT.
 - FLOATING TURBIDITY CONTAINMENT DEVICES SHALL GENERALLY BE COMPOSED OF A WATER SURFACE FLOATATION BOOM WITH A MINIMUM FREEBOARD OF 4 INCHES, A CURTAIN HANGING VERTICALLY TO THE REQUIRED DEPTH, BALLAST WEIGHT AT THE CURTAIN BOTTOM, AND SUFFICIENT ANCHORS TO MAINTAIN THE CURTAIN IN PLACE. TYPICAL CONFIGURATION PROVIDED IN TURBIDITY DEVICE CONFIGURATION DETAIL ON THIS SHEET.
 - THE FLOATING TURBIDITY CONTAINMENT DEVICE CURTAIN MATERIAL SHALL BE MONOFILAMENT WOVEN POLYPROPYLENE WITH THE FOLLOWING MINIMUM PHYSICAL REQUIREMENTS:

PROPERTY	VALUE	TEST METHOD
CRAB STRENGTH	200 LBS	ASTM D 4632
PUNCTURE	90 LBS	ASTM D 4833
TRAPEZOID TEAR	90 LBS	ASTM D 4533

- PERVIOUS GEOTEXTILE CURTAIN MATERIAL SHALL HAVE A MAXIMUM APPARENT OPENING SIZE (AOS) AND PERCENT OPEN AREA (POA) CAPABLE OF RETAINING FINE SUSPENDED SEDIMENTS 0.004 MM OR LARGER IN DIAMETER.
- A DESCRIPTION OF THE TURBIDITY CONTAINMENT DEVICE(S), THEIR MATERIALS AND DESIGN, AND THE PROPOSED DEPLOYMENT METHODOLOGY SHALL BE INCLUDED IN THE ENVIRONMENTAL PROTECTION PLAN AND APPROVED BY THE STATE PRIOR TO THEIR USE.
 - TURBIDITY CONTAINMENT DEVICES AND SILT FENCES SHALL BE INSPECTED DAILY, AND IMMEDIATELY REPAIRED OR REPLACED AS NECESSARY TO ENSURE THEIR EFFECTIVENESS.
 - A SILT FENCE SHALL BE INSTALLED AND MAINTAINED AROUND THE TEMPORARY STOCKPILE AREA AND EQUIPMENT/MATERIALS STAGING AREAS.
 - SILT FENCE FILTER FABRIC SHALL BE MIRAFI SILT FENCE, AMOCO SILT STOP, OR APPROVED EQUIVALENT.
 - CONSTRUCTION ENTRANCES SHALL BE STABILIZED WHEREVER TRAFFIC WILL BE ENTERING OR LEAVING THE CONSTRUCTION SITE, TEMPORARY STOCKPILE AREA AND STAGING AREA(S). IF THE ENTRANCE IS NOT PROPERLY PREVENTING SEDIMENT FROM BEING TRACKED ONTO PAVEMENT, THEN ALTERNATE MEASURES TO EFFECTIVELY KEEP THE STREET FREE OF SEDIMENT SHALL BE EMPLOYED.
 - ANY SEDIMENT THAT IS TRACKED ONTO PAVED ROADWAYS SHALL BE REMOVED BY SHOVELING OR STREET SWEEPING. THE SEDIMENT COLLECTED BY SWEEPING SHALL BE REMOVED OR STABILIZED ON SITE.
 - ANY GAPS/OPENINGS IN THE SILT FENCE SHALL BE CLOSED AT THE END OF EACH WORK DAY.
 - AN ENVIRONMENTAL PROTECTION PLAN AND A BEST MANAGEMENT PRACTICES PLAN SHALL BE SUBMITTED TO THE ENGINEER NO LATER THAN 2 WEEKS BEFORE COMMENCEMENT OF WORK.

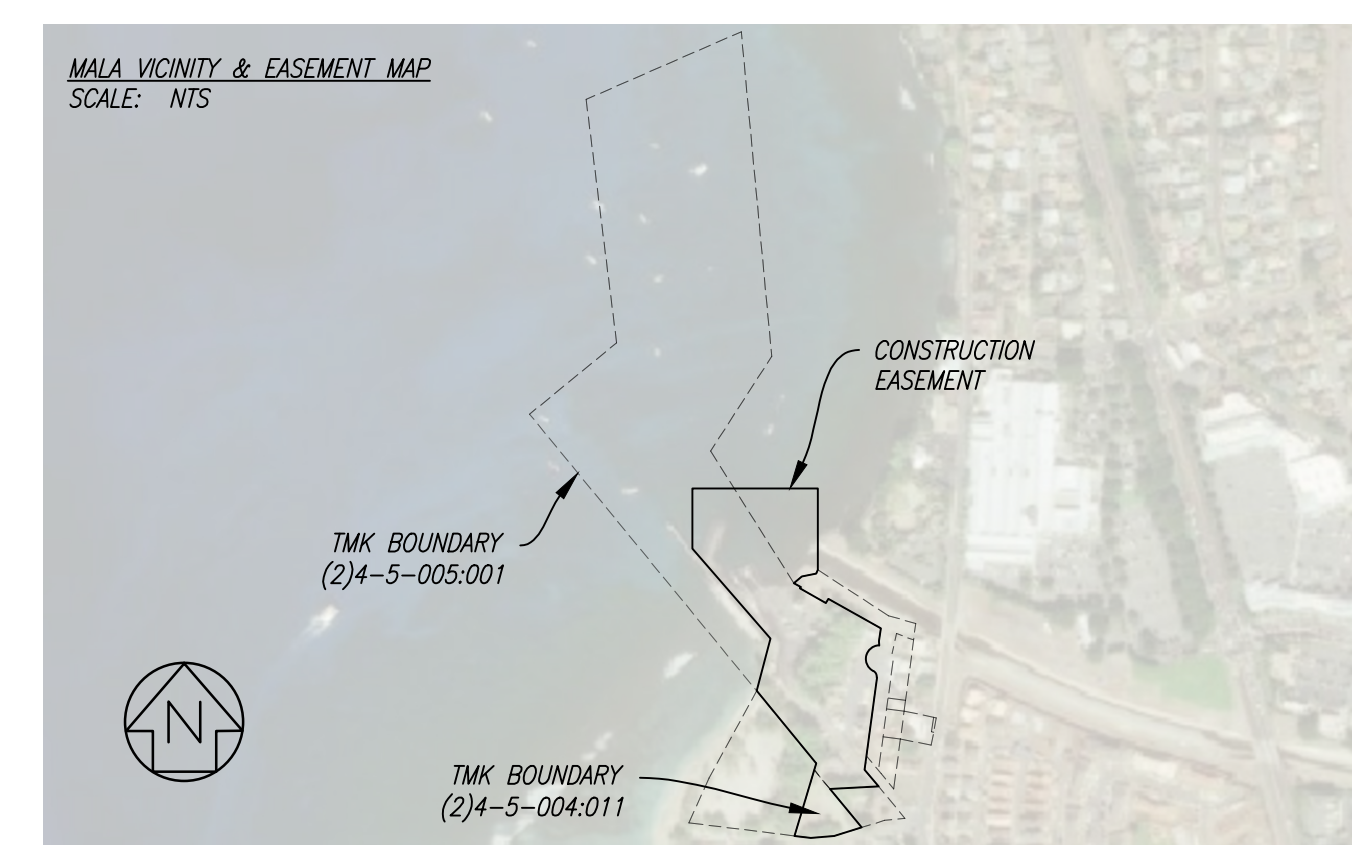

REVISION NO.	SYM.	DESCRIPTION	SHT. OF	DATE	APPROVED
STATE OF HAWAII DEPARTMENT OF LAND AND NATURAL RESOURCES ENGINEERING DIVISION MALA BOAT RAMP MAINTENANCE DREDGING STOCKPILE AREA & ENVIRONMENTAL CONTROLS					
DESIGNED: CCG, GW			SUBMITTED: NOT SUBMITTED		
DRAWN: CCG			DATE: 11 September 2024		
CHECKED: DRAFT			SCALE: AS SHOWN		
APPROVED: _____			DRAWING NO. _____		
SIGNATURE			DATE		
CHIEF ENGINEER			DATE		

60% DRAFT PLANS

C-3

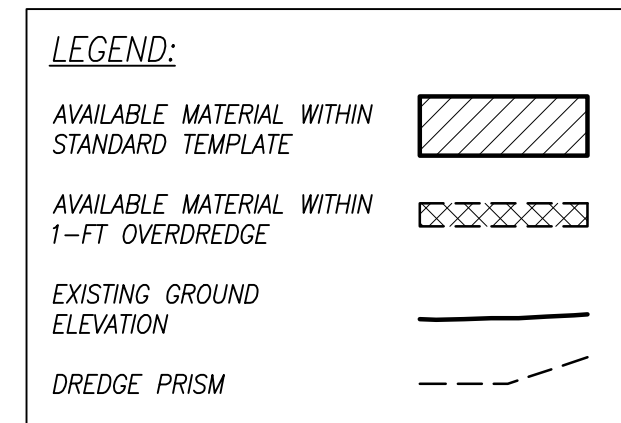
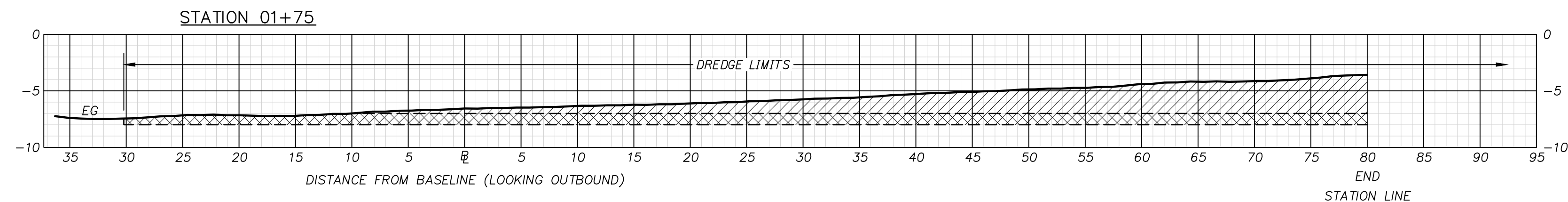
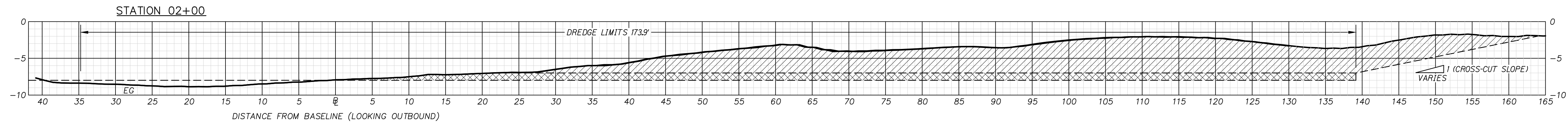

- DREDGING NOTES:
- BASILINE STA. 00+25 TO STA. 00+64.4 (WORK TASK 2): REMOVE EXISTING AVAILABLE OVERBURDEN OF SAND/SILT/GRAVEL OVER EXISTING CONCRETE BOAT RAMP. DEPTH OF AVAILABLE DREDGE MATERIAL OVER RAMP IS APPROXIMATED, CONTRACTOR SHALL VERIFY DEPTH OF THE CONCRETE RAMP BELOW. CONTRACTOR SHALL TAKE APPROPRIATE MEASURES AND INSTITUTE NECESSARY CONTROLS TO AVOID DAMAGE TO THE BOAT RAMP DURING CONSTRUCTION. ANY DAMAGE TO THE RAMP, PIERS, LOADING DOCKS, REVETMENTS, OR BREAKWATERS INCURRED FROM DREDGING OR RELATED CONSTRUCTION ACTIVITIES SHALL BE REPAIRED BY THE CONTRACTOR AT THEIR OWN EXPENSE. THERE IS NO OVER-DREDGE AUTHORIZED FOR THIS AREA. IF ENTIRE LENGTH OF BOAT RAMP IS FOUND BY CONTRACTOR TO BE COMPLETELY EXPOSED, WITH NO OVERBURDEN OF SAND OR SEDIMENT, THE CONTRACTOR SHALL NOTIFY THE ENGINEER AND OMIT THIS AREA.
 - BASILINE STA. 00+64.4 TO STA. 00+75 (WORK TASK 1): DREDGE SLOPING TRANSITION FOR LIMITED AREA BETWEEN END OF CONCRETE RAMP (NEAR STATION 00+64.4) AND START OF FULL PROJECT DEPTH (-7 FT MLLW) AT STATION 00+75, NOT EXCEEDING A MAXIMUM SLOPE OF 1:3 (V:H). TRANSITION SLOPE SHALL START AT EXISTING ELEVATION AT BOTTOM END OF RAMP AND PROCEED DOWN TO PROJECT DEPTH AT (-7 FT MLLW). IF THE BOTTOM OF RAMP ELEVATION IS FOUND TO BE EQUAL TO OR GREATER THAN THE PROJECT DEPTH OF 7 FT, THE CONTRACTOR SHALL DREDGE ONLY AS FAR AS THE PROJECT DEPTH TO PRODUCE A HORIZONTAL TRANSITION BETWEEN STATIONS 00+64.4 AND 00+75.
 - BASILINE STA. 00+75 TO STA. 02+78 (WORK TASK 1): DREDGE WITHIN PROJECT LIMITS TO THE PROJECT DEPTH OF 7 FT BELOW MLLW AS INDICATED IN THESE PLANS, WITH DESIGN SIDE SLOPES OF 1V:3H. CONTRACTOR SHALL DREDGE TO THE PROJECT LIMIT LINES UNTIL THE COLLAPSING SIDE SLOPE HAS STABILIZED AND THE PROJECT DEPTH IS MAINTAINED AT THE PROJECT LIMIT. THE LOCATION AND TOP ELEVATION OF EXISTING HARD ROCK SIDE SLOPES IS NOT KNOWN AT ALL LOCATIONS. IF, AFTER ACHIEVING SIDE SLOPES OF 1:3 AND SAND COLLAPSES INTO THE PROJECT AREA FROM SHALLOWER DEPTHS DUE TO ITS NATURAL ANGLE OF REPOSE, THE CONTRACTOR SHALL CONTINUE DREDGING UNTIL THE SIDE SLOPE IS EVENTUALLY STABILIZED AND THE PROJECT DEPTH IS MAINTAINED AT THE PROJECT LIMITS.
 - OFFLOAD BASILINE STA. 01+13.3 TO STA. 02+00 (WORK TASK 1): DREDGE WITHIN PROJECT LIMITS TO THE PROJECT DEPTH OF 7 FT BELOW MLLW AS INDICATED IN THESE PLANS, WITH DESIGN SIDE SLOPES OF 1V:3H. CONTRACTOR SHALL DREDGE TO THE PROJECT LIMIT LINES UNTIL THE COLLAPSING SIDE SLOPE HAS STABILIZED AND THE PROJECT DEPTH IS MAINTAINED AT THE PROJECT LIMIT. THE LOCATION AND TOP ELEVATION OF EXISTING HARD ROCK SIDE SLOPES IS NOT KNOWN AT ALL LOCATIONS. IF, AFTER ACHIEVING SIDE SLOPES OF 1:3 AND SAND COLLAPSES INTO THE PROJECT AREA FROM SHALLOWER DEPTHS DUE TO ITS NATURAL ANGLE OF REPOSE, THE CONTRACTOR SHALL CONTINUE DREDGING UNTIL THE SIDE SLOPE IS EVENTUALLY STABILIZED AND THE PROJECT DEPTH IS MAINTAINED AT THE PROJECT LIMITS.
 - THIS PROJECT CONSISTS OF MAINTENANCE DREDGING ONLY. CONTRACTOR SHALL NOT DREDGE INTO UNDISTURBED ROCK OR OTHER HARD BOTTOM.
 - AN OVER-DREDGE ALLOWANCE OF 1 FT (TO ELEV. -8 FT MLLW) IS AUTHORIZED FOR AREAS INCLUDED WITHIN WORK TASK 1, EXCLUDING THE RAMP TRANSITION AREA FROM BASILINE STATION 00+64.4 TO 00+75, ALL SIDE SLOPE AREAS, AND THE ENTIRE AREA DESIGNATED FOR WORK TASK 2.
 - VOLUME OF AVAILABLE DREDGE MATERIAL BASED ON THE GIVEN LIMITS IS APPROXIMATELY 2,620 CY TO THE STANDARD DREDGE TEMPLATE, AS SHOWN IN THESE PLANS (WORK TASK 1 AND 2 COMBINED). A TOTAL VOLUME OF APPROXIMATELY 3350 CY IS AVAILABLE TO THE STANDARD DREDGE TEMPLATE PLUS ALLOWABLE 1 FT OVER-DREDGE.
 - HYDRAULIC DREDGING OR BLASTING IS NOT PERMITTED AT ANY TIME.
 - MAINTENANCE DREDGING SHALL BE DONE BY MECHANICAL DREDGING METHODS ONLY. THE CONSTRUCTION OF A CAUSEWAY FOR THE PURPOSE OF DREDGING IS NOT ALLOWED. MAINTENANCE DREDGING SHALL INCLUDE THE DREDGING OF LOOSE MATERIALS. LOOSE MATERIALS ARE DEFINED IN THE CONTRACT SPECIFICATION ENTITLED "DREDGING".
 - CONTRACTOR SHALL DREDGE TO THE PROVIDED PROJECT LIMITS AS SHOWN IN THESE PLANS. THE DREDGE LIMITS DELINEATED ON SHEETS C-2 THROUGH C-4 REPRESENT THE DREDGE TEMPLATE AND ALLOWABLE OVER-DREDGE. SIDE SLOPES ARE APPROXIMATED ON THESE SHEETS FOR REFERENCE. BREAKWATER OR REVETMENT STAND-OFF DISTANCES ARE NOTED WHERE APPLICABLE (SEE NOTE 11 ON THIS SHEET).
 - AT NO TIME SHALL THE CONTRACTOR DREDGE CLOSER THAN 20 FEET HORIZONTALLY TO THE 0.0' ELEVATION MLLW WATERLINE ON THE BREAKWATER OR SHORELINE REVETMENTS, OR DISTURB THE FOUNDATION TOE STONES OF THE BREAKWATER OR SHORELINE REVETMENTS. IF A DISCREPANCY IS FOUND BETWEEN THIS REQUIREMENT AND THE LOCATION OF THE DREDGING PROJECT LIMITS, THE CONTRACTOR SHALL NOTIFY THE ENGINEER AND THE CONTRACTING OFFICER'S REPRESENTATIVE IMMEDIATELY.
 - THE LOCATION AND ELEVATION OF THE BOTTOM END OF THE CONCRETE BOAT RAMP IS UNVERIFIED. CONTRACTOR SHALL VERIFY PHYSICAL LIMITS OF THE RAMP FOR AWARENESS DURING CONSTRUCTION ACTIVITIES. CONTRACTOR SHALL EXERCISE CAUTION AND IMPLEMENT APPROPRIATE CONTROLS TO AVOID DAMAGE TO THE CONCRETE RAMP WHILE DREDGING IN THE RAMP VICINITY.

- HYDROGRAPHIC SURVEY NOTES:
- HYDROGRAPHIC SURVEY COMPLETED 03 MAY 2023 BY SEA ENGINEERING.
 - EXISTING DEPTH PROFILES ARE ELEVATIONS IN FEET REFERENCED TO THE MLLW DATUM PUBLISHED FOR KAHULUI HARBOR.
 - CROSS SECTION ORIENTATION AT ALL STATIONS IS AS VIEWED MOVING OUTBOUND ALONG THE BASILINE (LOOKING NORTHWARD).

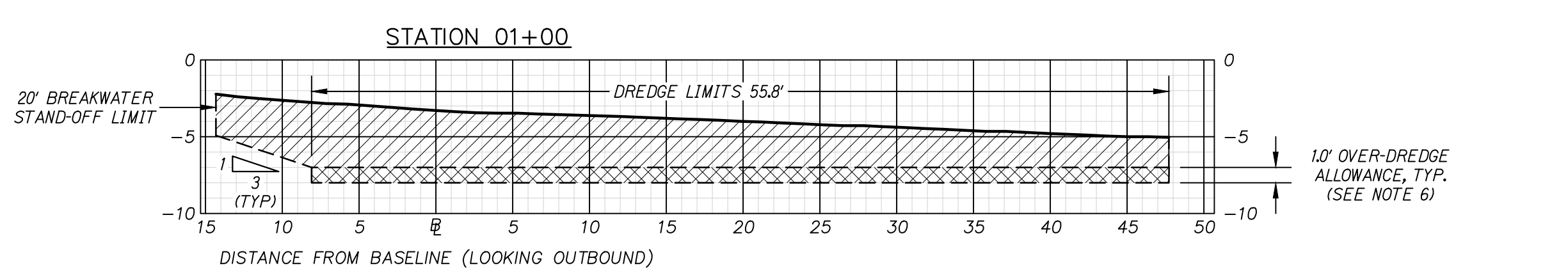
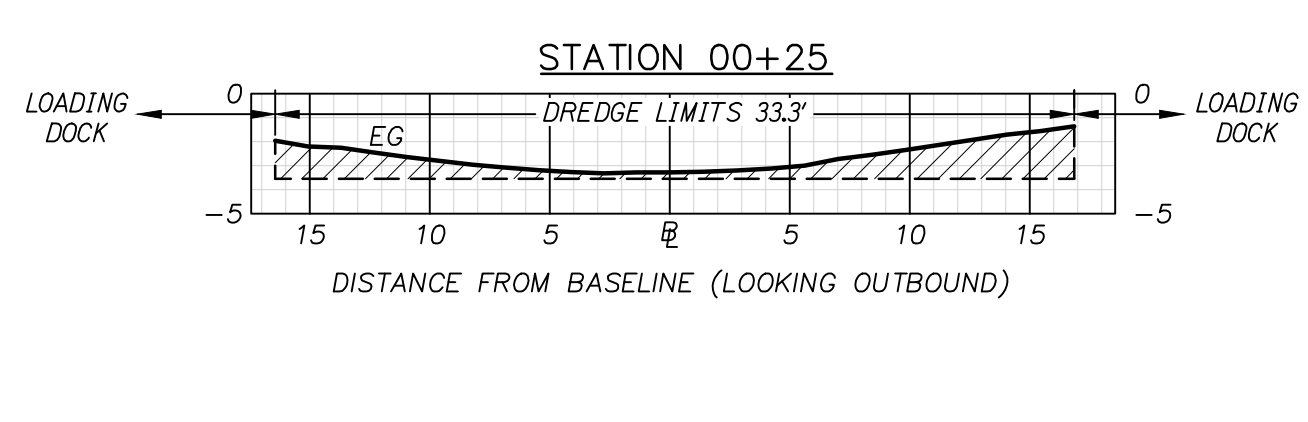
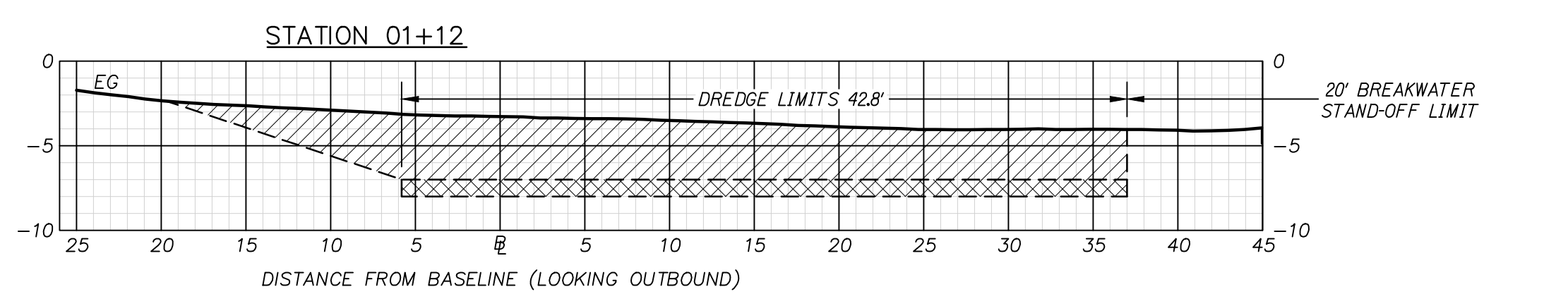
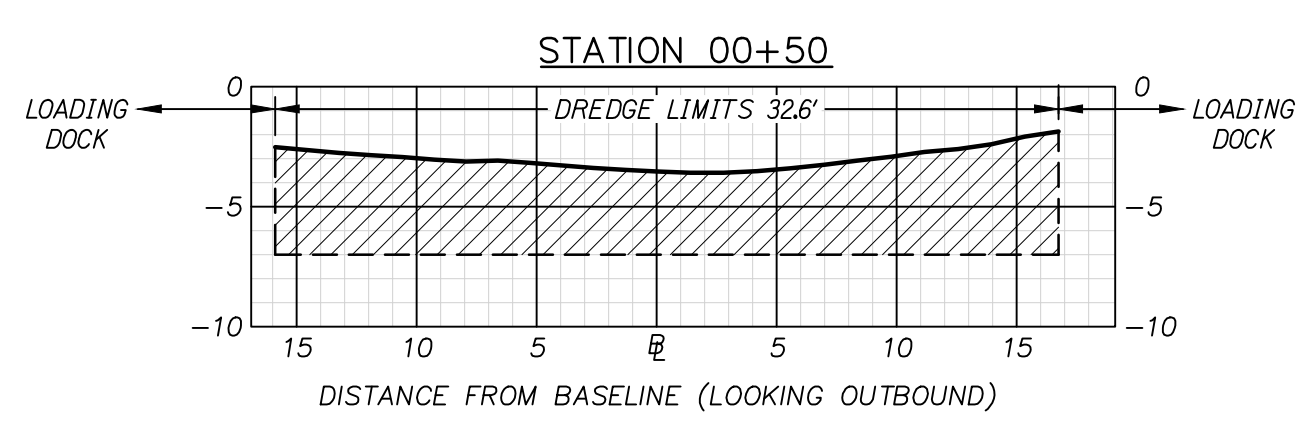
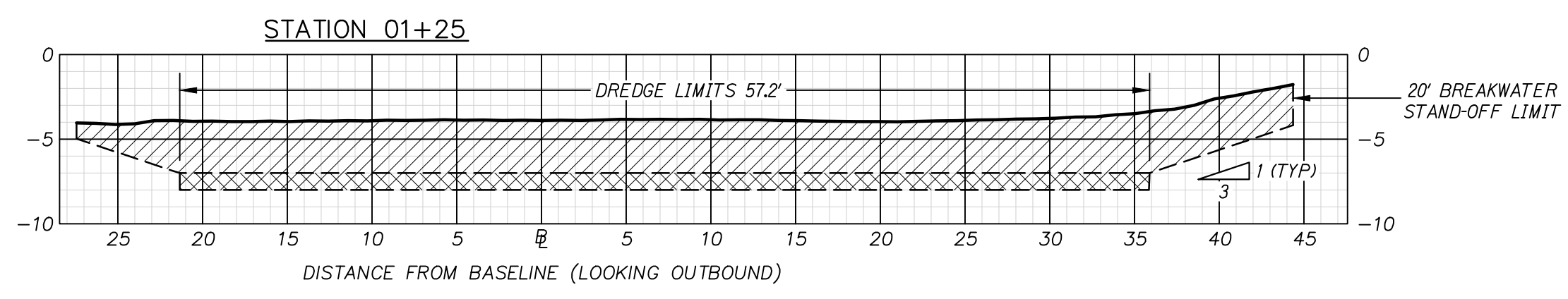
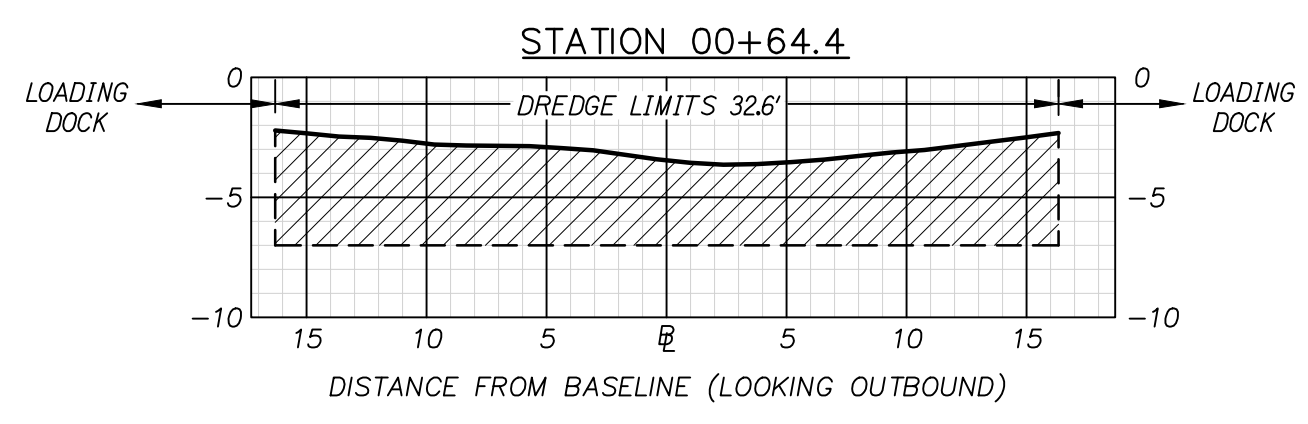
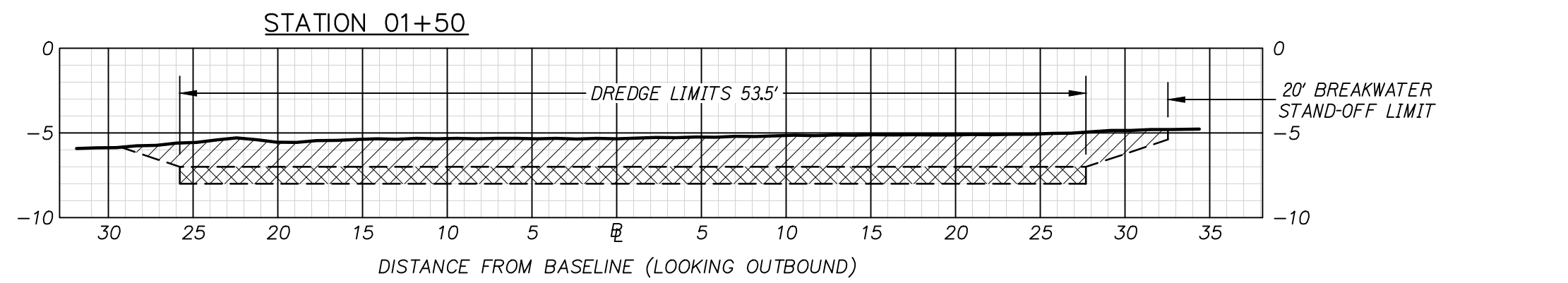
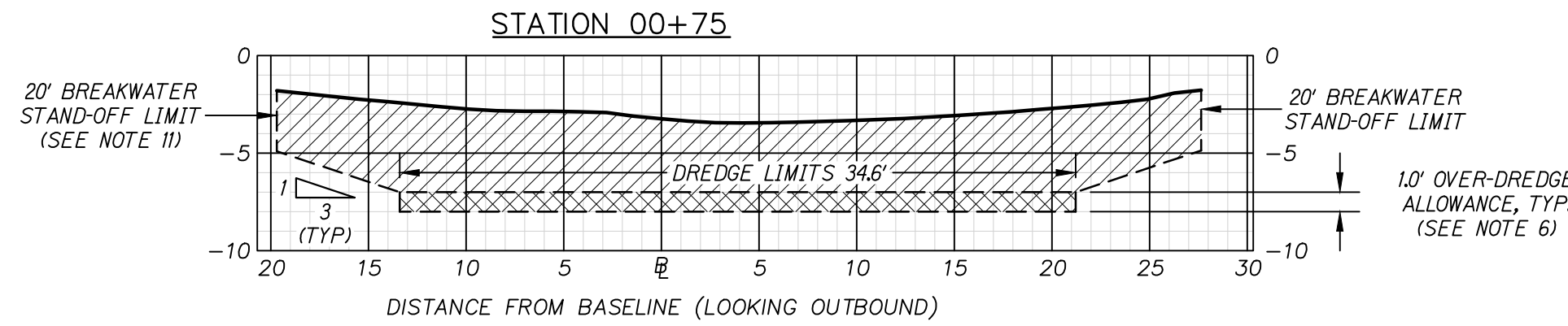

DREDGE PLAN CROSS SECTIONS - 1
Scale: 1" = 8'

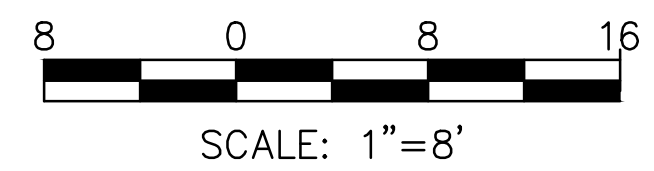

REVISION NO.	SYM.	DESCRIPTION	SHT. OF	DATE	APPROVED
STATE OF HAWAII DEPARTMENT OF LAND AND NATURAL RESOURCES ENGINEERING DIVISION					
MALA BOAT RAMP MAINTENANCE DREDGING					
DREDGE PLAN CROSS SECTIONS - 1					
DESIGNED: CCG			SUBMITTED: NOT SUBMITTED		
DRAWN: CCG, GW			DATE: 11 September 2024		
CHECKED: DRAFT			SCALE: 1 IN = 8 FT		
APPROVED:			DRAWING NO.		
SIGNATURE			DATE		
CHIEF ENGINEER			DATE		

60% DRAFT PLANS C-4

/Users/goodster/Library/CloudStorage/OneDrive-SanEngineering/Lahaina & Mala Dredge/DWG/EO_PCT/Mala/WORKING REVISIONS/20240909/6 - C-4 - SECTIONS.dwg, Thu Sep 12 14:53:12 2024, ANSI
 1:1, *** NOT FOR CONSTRUCTION ***

I:\Users\goodster\Library\CloudStorage\OneDrive\Sea Engineering\Laaina & Mala Dredge\DWG\EO_PCT\Mala\WORKING REVISIONS\20240909\6 - C-4 - SECTIONS.dwg, Thu Sep 12 14:53:13 2024, ANSI

DRAFT PLANS - NOT FOR CONSTRUCTION

DREDGE PLAN CROSS SECTIONS - 2

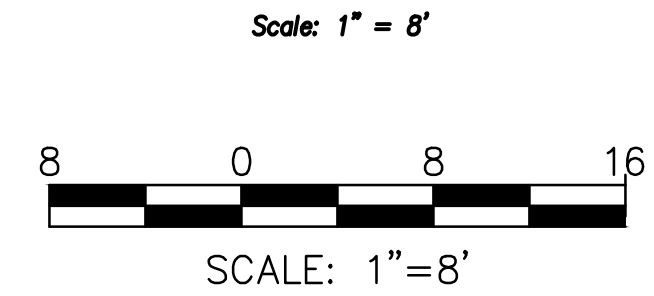

LEGEND:

- AVAILABLE MATERIAL WITHIN STANDARD TEMPLATE
- AVAILABLE MATERIAL WITHIN 1-FT OVERDREDGE
- EXISTING GROUND ELEVATION
- DREDGE PRISM

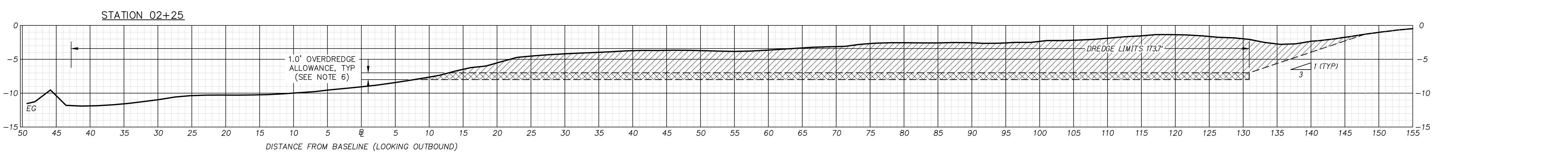
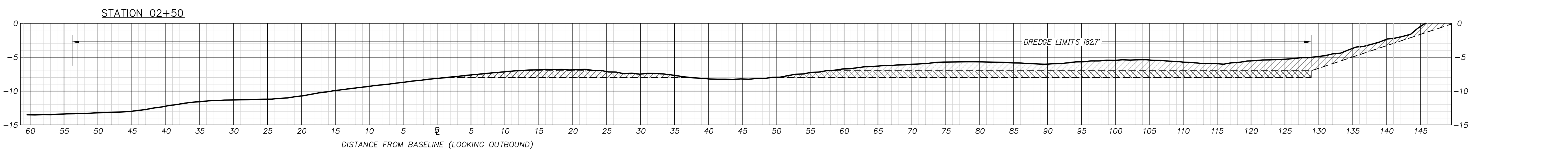
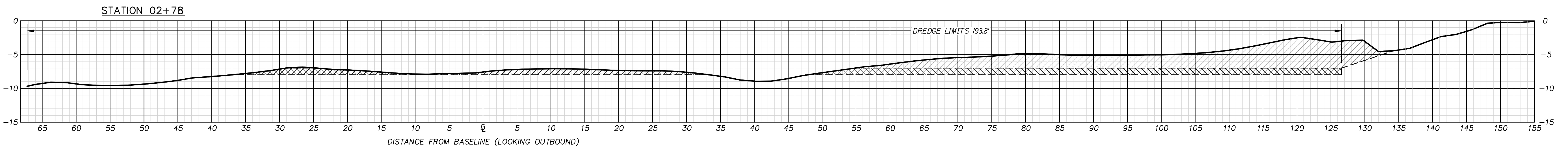
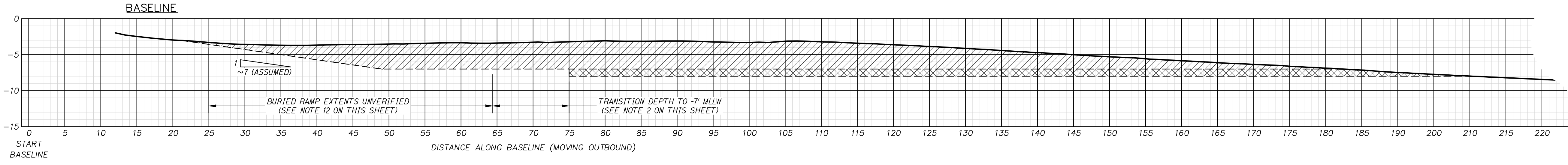
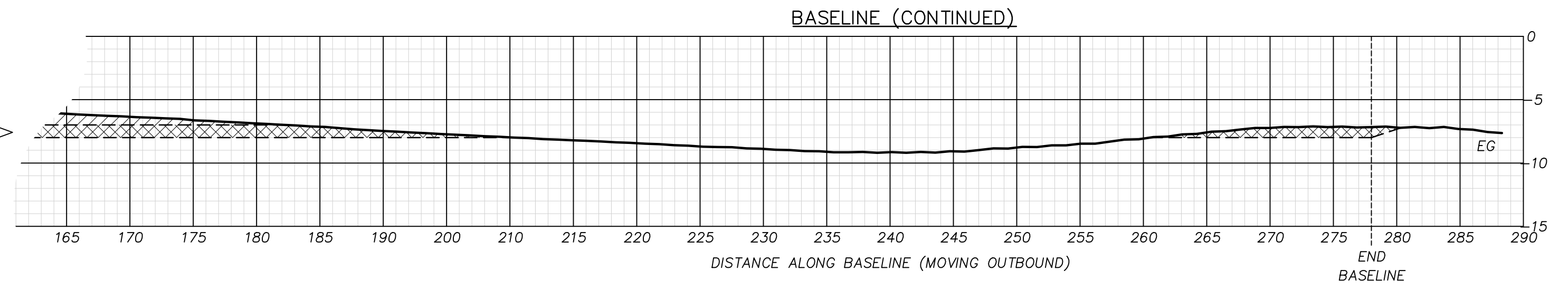

DREDGING NOTES:

1. **BASELINE STA 00+25 TO STA 00+64.4 (WORK TASK 2):** REMOVE EXISTING AVAILABLE OVERBURDEN OF SAND/SILT/GRAVEL OVER EXISTING CONCRETE BOAT RAMP. DEPTH OF AVAILABLE DREDGE MATERIAL OVER RAMP IS APPROXIMATED, CONTRACTOR SHALL VERIFY DEPTH OF THE CONCRETE RAMP BELOW. CONTRACTOR SHALL TAKE APPROPRIATE MEASURES AND INSTITUTE NECESSARY CONTROLS TO AVOID DAMAGE TO THE BOAT RAMP DURING CONSTRUCTION. ANY DAMAGE TO THE RAMP, PIERS, LOADING DOCKS, REVETMENTS, OR BREAKWATERS INCURRED FROM DREDGING OR RELATED CONSTRUCTION ACTIVITIES SHALL BE REPAIRED BY THE CONTRACTOR AT THEIR OWN EXPENSE. THERE IS NO OVER-DREDGE AUTHORIZED FOR THIS AREA. IF ENTIRE LENGTH OF BOAT RAMP IS FOUND BY CONTRACTOR TO BE COMPLETELY EXPOSED, WITH NO OVERBURDEN OF SAND OR SEDIMENT, THE CONTRACTOR SHALL NOTIFY THE ENGINEER AND OMIT THIS AREA.
2. **BASELINE STA 00+64.4 TO STA 00+75 (WORK TASK 1):** DREDGE SLOPING TRANSITION FOR LIMITED AREA BETWEEN END OF CONCRETE RAMP (NEAR STATION 00+64.4) AND START OF FULL PROJECT DEPTH (-7 FT MLLW) AT STATION 00+75, NOT EXCEEDING A MAXIMUM SLOPE OF 1:3 (V:H). TRANSITION SLOPE SHALL START AT EXISTING ELEVATION AT BOTTOM END OF RAMP AND PROCEED DOWN TO PROJECT DEPTH AT (-7 FT MLLW). IF THE BOTTOM OF RAMP ELEVATION IS FOUND TO BE EQUAL TO OR GREATER THAN THE PROJECT DEPTH OF 7 FT, THE CONTRACTOR SHALL DREDGE ONLY AS FAR AS THE PROJECT DEPTH TO PRODUCE A HORIZONTAL TRANSITION BETWEEN STATIONS 00+64.4 AND 00+75.
3. **BASELINE STA 00+75 TO STA 02+78 (WORK TASK 1):** DREDGE WITHIN PROJECT LIMITS TO THE PROJECT DEPTH OF 7 FT BELOW MLLW AS INDICATED IN THESE PLANS, WITH DESIGN SIDE SLOPES OF 1V:3H. CONTRACTOR SHALL DREDGE TO THE PROJECT LIMIT LINES UNTIL THE COLLAPSING SIDE SLOPE HAS STABILIZED AND THE PROJECT DEPTH IS MAINTAINED AT THE PROJECT LIMIT. THE LOCATION AND TOP ELEVATION OF EXISTING HARD ROCK SIDE SLOPES IS NOT KNOWN AT ALL LOCATIONS. IF, AFTER ACHIEVING SIDE SLOPES OF 1:3 AND SAND COLLAPSES INTO THE PROJECT AREA FROM SHALLOWER DEPTHS DUE TO ITS NATURAL ANGLE OF REPOSE, THE CONTRACTOR SHALL CONTINUE DREDGING UNTIL THE SIDE SLOPE IS EVENTUALLY STABILIZED AND THE PROJECT DEPTH IS MAINTAINED AT THE PROJECT LIMITS.
4. **OFFLOAD BASELINE STA 01+13.3 TO STA 02+00 (WORK TASK 1):** DREDGE WITHIN PROJECT LIMITS TO THE PROJECT DEPTH OF 7 FT BELOW MLLW AS INDICATED IN THESE PLANS, WITH DESIGN SIDE SLOPES OF 1V:3H. CONTRACTOR SHALL DREDGE TO THE PROJECT LIMIT LINES UNTIL THE COLLAPSING SIDE SLOPE HAS STABILIZED AND THE PROJECT DEPTH IS MAINTAINED AT THE PROJECT LIMIT. THE LOCATION AND TOP ELEVATION OF EXISTING HARD ROCK SIDE SLOPES IS NOT KNOWN AT ALL LOCATIONS. IF, AFTER ACHIEVING SIDE SLOPES OF 1:3 AND SAND COLLAPSES INTO THE PROJECT AREA FROM SHALLOWER DEPTHS DUE TO ITS NATURAL ANGLE OF REPOSE, THE CONTRACTOR SHALL CONTINUE DREDGING UNTIL THE SIDE SLOPE IS EVENTUALLY STABILIZED AND THE PROJECT DEPTH IS MAINTAINED AT THE PROJECT LIMITS.
5. THIS PROJECT CONSISTS OF MAINTENANCE DREDGING ONLY. CONTRACTOR SHALL NOT DREDGE INTO UNDISTURBED ROCK OR OTHER HARD BOTTOM.
6. AN OVER-DREDGE ALLOWANCE OF 1 FT (TO ELEV. -8 FT MLLW) IS AUTHORIZED FOR AREAS INCLUDED WITHIN WORK TASK 1, EXCLUDING THE RAMP TRANSITION AREA FROM BASELINE STATION 00+64.4 TO 00+75, ALL SIDE SLOPE AREAS, AND THE ENTIRE AREA DESIGNATED FOR WORK TASK 2.
7. VOLUME OF AVAILABLE DREDGE MATERIAL BASED ON THE GIVEN LIMITS IS APPROXIMATELY 2,620 CY TO THE STANDARD DREDGE TEMPLATE, AS SHOWN IN THESE PLANS (WORK TASK 1 AND 2 COMBINED). A TOTAL VOLUME OF APPROXIMATELY 3350 CY IS AVAILABLE TO THE STANDARD DREDGE TEMPLATE PLUS ALLOWABLE 1 FT OVER-DREDGE.
8. HYDRAULIC DREDGING OR BLASTING IS NOT PERMITTED AT ANY TIME.
9. MAINTENANCE DREDGING SHALL BE DONE BY MECHANICAL DREDGING METHODS ONLY. THE CONSTRUCTION OF A CAUSEWAY FOR THE PURPOSE OF DREDGING IS NOT ALLOWED. MAINTENANCE DREDGING SHALL INCLUDE THE DREDGING OF LOOSE MATERIALS. LOOSE MATERIALS ARE DEFINED IN THE CONTRACT SPECIFICATION ENTITLED "DREDGING".
10. CONTRACTOR SHALL DREDGE TO THE PROVIDED PROJECT LIMITS AS SHOWN IN THESE PLANS. THE DREDGE LIMITS DELINEATED ON SHEETS C-2 THROUGH C-4 REPRESENT THE DREDGE TEMPLATE AND ALLOWABLE OVER-DREDGE. SIDE SLOPES ARE APPROXIMATED ON THESE SHEETS FOR REFERENCE. BREAKWATER OR REVETMENT STAND-OFF DISTANCES ARE NOTED WHERE APPLICABLE (SEE NOTE 11 ON THIS SHEET).
11. AT NO TIME SHALL THE CONTRACTOR DREDGE CLOSER THAN 20 FEET HORIZONTALLY TO THE 0.0' ELEVATION MLLW WATERLINE ON THE BREAKWATER OR SHORELINE REVETMENTS, OR DISTURB THE FOUNDATION TOE STONES OF THE BREAKWATER OR SHORELINE REVETMENTS. IF A DISCREPANCY IS FOUND BETWEEN THIS REQUIREMENT AND THE LOCATION OF THE DREDGING PROJECT LIMITS, THE CONTRACTOR SHALL NOTIFY THE ENGINEER AND THE CONTRACTING OFFICER'S REPRESENTATIVE IMMEDIATELY.
12. BURIED RAMP SLOPE IS ASSUMED AT APPROXIMATELY 7H:1V FOR THESE PLANS. ACTUAL SLOPE, AND LOCATION AND ELEVATION OF THE BOTTOM END OF THE CONCRETE BOAT RAMP IS UNVERIFIED. CONTRACTOR SHALL VERIFY PHYSICAL LIMITS OF THE RAMP FOR AWARENESS DURING DREDGING/CONSTRUCTION ACTIVITIES. CONTRACTOR SHALL EXERCISE CAUTION AND IMPLEMENT APPROPRIATE CONTROLS TO AVOID DAMAGE TO THE CONCRETE RAMP WHILE DREDGING IN THE RAMP VICINITY.

HYDROGRAPHIC SURVEY NOTES:

1. HYDROGRAPHIC SURVEY COMPLETED 03 MAY 2023 BY SEA ENGINEERING.
2. EXISTING DEPTH PROFILES ARE ELEVATIONS IN FEET REFERENCED TO THE MLLW DATUM PUBLISHED FOR KAHULUI HARBOR.
3. CROSS SECTION ORIENTATION AT ALL STATIONS IS AS VIEWED MOVING OUTBOUND ALONG THE BASELINE (LOOKING NORTHWARD).

REVISION NO.	SYM.	DESCRIPTION	SHT. OF	DATE	APPROVED
STATE OF HAWAII DEPARTMENT OF LAND AND NATURAL RESOURCES ENGINEERING DIVISION MALA BOAT RAMP MAINTENANCE DREDGING DREDGE PLAN CROSS SECTIONS - 2					
DESIGNED: CCG			SUBMITTED: NOT SUBMITTED		
DRAWN: CCG, GW			DATE: 11 September 2024		
CHECKED: DRAFT			SCALE: 1 IN = 8 FT		
APPROVED: _____			DRAWING NO. C-5		
SIGNATURE: _____			DATE: _____		

60% DRAFT PLANS

DREDGE PLAN CROSS SECTIONS - 3

Scale: 1" = 8'

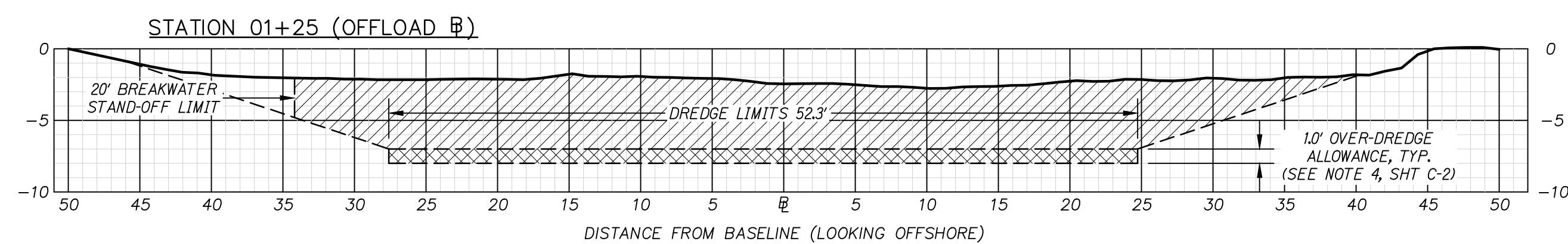
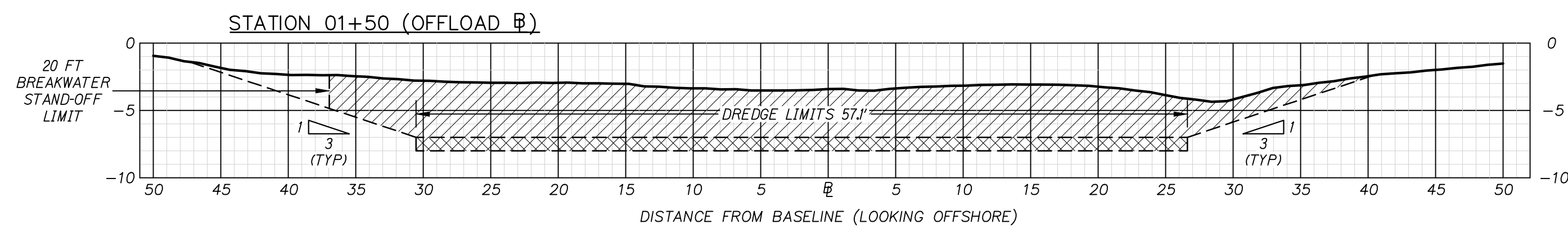
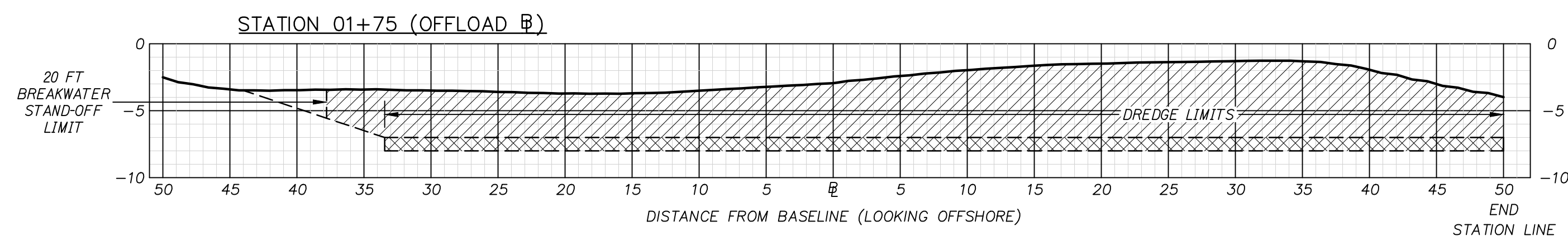
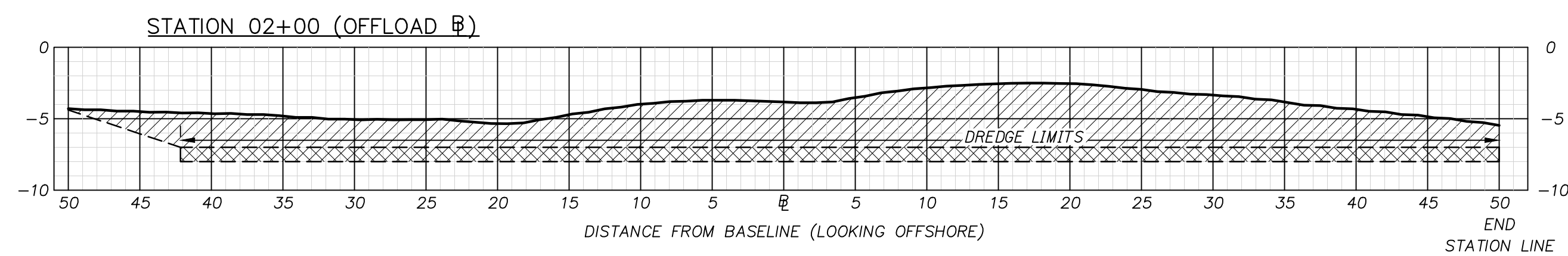
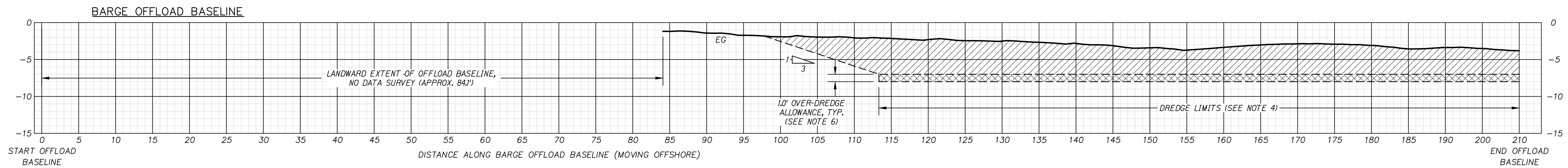

DREDGING NOTES:

- BASILINE STA. 00+25 TO STA. 00+64.4 (WORK TASK 2): REMOVE EXISTING AVAILABLE OVERBURDEN OF SAND/SILT/GRAVEL OVER EXISTING CONCRETE BOAT RAMP. DEPTH OF AVAILABLE DREDGE MATERIAL OVER RAMP IS APPROXIMATED, CONTRACTOR SHALL VERIFY DEPTH OF THE CONCRETE RAMP BELOW. CONTRACTOR SHALL TAKE APPROPRIATE MEASURES AND INSTITUTE NECESSARY CONTROLS TO AVOID DAMAGE TO THE BOAT RAMP DURING CONSTRUCTION. ANY DAMAGE TO THE RAMP, PIERS, LOADING DOCKS, REVETMENTS, OR BREAKWATERS INCURRED FROM DREDGING OR RELATED CONSTRUCTION ACTIVITIES SHALL BE REPAIRED BY THE CONTRACTOR AT THEIR OWN EXPENSE. THERE IS NO OVER-DREDGE AUTHORIZED FOR THIS AREA. IF ENTIRE LENGTH OF BOAT RAMP IS FOUND BY CONTRACTOR TO BE COMPLETELY EXPOSED, WITH NO OVERBURDEN OF SAND OR SEDIMENT, THE CONTRACTOR SHALL NOTIFY THE ENGINEER AND OMIT THIS AREA.
- BASILINE STA. 00+64.4 TO STA. 00+75 (WORK TASK 1): DREDGE SLOPING TRANSITION FOR LIMITED AREA BETWEEN END OF CONCRETE RAMP (NEAR STATION 0+64.4) AND START OF FULL PROJECT DEPTH (-7 FT MLLW) AT STATION 00+75, NOT EXCEEDING A MAXIMUM SLOPE OF 1:3 (V:H). TRANSITION SLOPE SHALL START AT EXISTING ELEVATION AT BOTTOM END OF RAMP AND PROCEED DOWN TO PROJECT DEPTH AT (-7 FT MLLW). IF THE BOTTOM OF RAMP ELEVATION IS FOUND TO BE EQUAL TO OR GREATER THAN THE PROJECT DEPTH OF 7 FT, THE CONTRACTOR SHALL DREDGE ONLY AS FAR AS THE PROJECT DEPTH TO PRODUCE A HORIZONTAL TRANSITION BETWEEN STATIONS 00+64.4 AND 00+75.
- BASILINE STA. 00+75 TO STA. 02+78 (WORK TASK 1): DREDGE WITHIN PROJECT LIMITS TO THE PROJECT DEPTH OF 7 FT BELOW MLLW AS INDICATED IN THESE PLANS, WITH DESIGN SIDE SLOPES OF 1V:3H. CONTRACTOR SHALL DREDGE TO THE PROJECT LIMIT LINES UNTIL THE COLLAPSING SIDE SLOPE HAS STABILIZED AND THE PROJECT DEPTH IS MAINTAINED AT THE PROJECT LIMIT. THE LOCATION AND TOP ELEVATION OF EXISTING HARD ROCK SIDE SLOPES IS NOT KNOWN AT ALL LOCATIONS. IF, AFTER ACHIEVING SIDE SLOPES OF 1:3 AND SAND COLLAPSES INTO THE PROJECT AREA FROM SHALLOWER DEPTHS DUE TO ITS NATURAL ANGLE OF REPOSE, THE CONTRACTOR SHALL CONTINUE DREDGING UNTIL THE SIDE SLOPE IS EVENTUALLY STABILIZED AND THE PROJECT DEPTH IS MAINTAINED AT THE PROJECT LIMITS.
- OFFLOAD BASELINE STA. 01+13.3 TO STA. 02+00 (WORK TASK 1): DREDGE WITHIN PROJECT LIMITS TO THE PROJECT DEPTH OF 7 FT BELOW MLLW AS INDICATED IN THESE PLANS, WITH DESIGN SIDE SLOPES OF 1V:3H. CONTRACTOR SHALL DREDGE TO THE PROJECT LIMIT LINES UNTIL THE COLLAPSING SIDE SLOPE HAS STABILIZED AND THE PROJECT DEPTH IS MAINTAINED AT THE PROJECT LIMIT. THE LOCATION AND TOP ELEVATION OF EXISTING HARD ROCK SIDE SLOPES IS NOT KNOWN AT ALL LOCATIONS. IF, AFTER ACHIEVING SIDE SLOPES OF 1:3 AND SAND COLLAPSES INTO THE PROJECT AREA FROM SHALLOWER DEPTHS DUE TO ITS NATURAL ANGLE OF REPOSE, THE CONTRACTOR SHALL CONTINUE DREDGING UNTIL THE SIDE SLOPE IS EVENTUALLY STABILIZED AND THE PROJECT DEPTH IS MAINTAINED AT THE PROJECT LIMITS.
- THIS PROJECT CONSISTS OF MAINTENANCE DREDGING ONLY. CONTRACTOR SHALL NOT DREDGE INTO UNDISTURBED ROCK OR OTHER HARD BOTTOM.
- AN OVER-DREDGE ALLOWANCE OF 1 FT (TO ELEV. -8 FT MLLW) IS AUTHORIZED FOR AREAS INCLUDED WITHIN WORK TASK 1, EXCLUDING THE RAMP TRANSITION AREA FROM BASELINE STATION 00+64.4 TO 00+75, ALL SIDE SLOPE AREAS, AND THE ENTIRE AREA DESIGNATED FOR WORK TASK 2.
- VOLUME OF AVAILABLE DREDGE MATERIAL BASED ON THE GIVEN LIMITS IS APPROXIMATELY 2,620 CY TO THE STANDARD DREDGE TEMPLATE, AS SHOWN IN THESE PLANS (WORK TASK 1 AND 2 COMBINED). A TOTAL VOLUME OF APPROXIMATELY 3,350 CY IS AVAILABLE TO THE STANDARD DREDGE TEMPLATE PLUS ALLOWABLE 1 FT OVER-DREDGE.
- HYDRAULIC DREDGING OR BLASTING IS NOT PERMITTED AT ANY TIME.
- MAINTENANCE DREDGING SHALL BE DONE BY MECHANICAL DREDGING METHODS ONLY. THE CONSTRUCTION OF A CAUSEWAY FOR THE PURPOSE OF DREDGING IS NOT ALLOWED. MAINTENANCE DREDGING SHALL INCLUDE THE DREDGING OF LOOSE MATERIALS. LOOSE MATERIALS ARE DEFINED IN THE CONTRACT SPECIFICATION ENTITLED "DREDGING".
- CONTRACTOR SHALL DREDGE TO THE PROVIDED PROJECT LIMITS AS SHOWN IN THESE PLANS. THE DREDGE LIMITS DELINEATED ON SHEETS C-2 THROUGH C-4 REPRESENT THE DREDGE TEMPLATE AND ALLOWABLE OVER-DREDGE. SIDE SLOPES ARE APPROXIMATED ON THESE SHEETS FOR REFERENCE. BREAKWATER OR REVETMENT STAND-OFF DISTANCES ARE NOTED WHERE APPLICABLE (SEE NOTE 11 ON THIS SHEET).
- AT NO TIME SHALL THE CONTRACTOR DREDGE CLOSER THAN 20 FEET HORIZONTALLY TO THE 0.0' ELEVATION MLLW WATERLINE ON THE BREAKWATER OR SHORELINE REVETMENTS, OR DISTURB THE FOUNDATION TOE STONES OF THE BREAKWATER OR SHORELINE REVETMENTS. IF A DISCREPANCY IS FOUND BETWEEN THIS REQUIREMENT AND THE LOCATION OF THE DREDGING PROJECT LIMITS, THE CONTRACTOR SHALL NOTIFY THE ENGINEER AND THE CONTRACTING OFFICER'S REPRESENTATIVE IMMEDIATELY.
- THE LOCATION AND ELEVATION OF THE BOTTOM END OF THE CONCRETE BOAT RAMP IS UNVERIFIED. CONTRACTOR SHALL VERIFY PHYSICAL LIMITS OF THE RAMP FOR AWARENESS DURING CONSTRUCTION ACTIVITIES. CONTRACTOR SHALL EXERCISE CAUTION AND IMPLEMENT APPROPRIATE CONTROLS TO AVOID DAMAGE TO THE CONCRETE RAMP WHILE DREDGING IN THE RAMP VICINITY.

HYDROGRAPHIC SURVEY NOTES:

- HYDROGRAPHIC SURVEY COMPLETED 03 MAY 2023 BY SEA ENGINEERING.
- EXISTING DEPTH PROFILES ARE ELEVATIONS IN FEET REFERENCED TO THE MLLW DATUM PUBLISHED FOR KAHULUI HARBOR.
- CROSS SECTION ORIENTATION AT ALL STATIONS IS AS VIEWED MOVING OUTBOUND ALONG THE BASELINE (LOOKING NORTHWARD).

LEGEND:

- AVAILABLE MATERIAL WITHIN STANDARD TEMPLATE (diagonal hatching)
- AVAILABLE MATERIAL WITHIN 1-FT OVERDREDGE (cross-hatching)
- EXISTING GROUND ELEVATION (solid line)
- DREDGE PRISM (dashed line)



REVISION NO.	SYM.	DESCRIPTION	SHT. OF	DATE	APPROVED
STATE OF HAWAII DEPARTMENT OF LAND AND NATURAL RESOURCES ENGINEERING DIVISION					
MALA BOAT RAMP MAINTENANCE DREDGING					
DREDGE PLAN CROSS SECTIONS - 3					
DESIGNED: CCG			SUBMITTED: NOT SUBMITTED		
DRAWN: CCG, GW			DATE: 11 September 2024		
CHECKED: DRAFT			SCALE: 1 IN = 8 FT		
APPROVED: _____			DRAWING NO. C-6		
SIGNATURE: _____			DATE: _____		
CHIEF ENGINEER			DATE		

/Users/goodster/Library/CloudStorage/OneDrive/Mala Dredge/DWG/EO_PCT/Mala/WORKING REVISIONS/20240909/6 - C-4 - SECTIONS.dwg, Thu Sep 12 14:53:14 2024, ANSI
 1:1, *** NOT FOR CONSTRUCTION ***

7.0 Pac-SLOPES BMPs

The Corps will include applicable BMPs for the activities identified in Section 2.0 as permit conditions:

A. General BMPs

1. The Corps will retain the right of reasonable access to projects authorized under Pac-SLOPES to monitor the compliance with and effectiveness of permit conditions.
2. For in-water work where ESA corals may occur, structures and substrate that could be affected by the proposed activity must be surveyed by personnel qualified to identify ESA-listed corals. Where divers are to be used, before entering the water, all divers shall be made aware of ESA-listed corals, and the requirement to avoid contact with the corals while performing their duties. This shall include taking measures to avoid kicking corals with fins and to secure dive and survey equipment in a manner that will prevent the equipment from being dragged across the substrate.
3. To minimize impacts to coral larvae, notably the listed species covered in this programmatic consultation, the permittee shall avoid in-water work during mass-coral spawning times or peak coral spawning seasons June 1 to September 30 if practicable. The Corps must consult with their local NMFS HCD biologist to determine the period and dates when coral spawning will occur for the given year.
4. Constant vigilance shall be kept for the presence of ESA-listed marine species (sea turtles, marine mammals, sharks, rays) during all aspects of the proposed action.
5. A responsible party (i.e. permittee/site manager/project supervisor) shall designate an appropriate number of competent trained observers⁴ to survey the areas adjacent to the authorized work area (i.e. proposed action) for ESA-listed marine species. The competent observer will not be simultaneously engaged in any other activity (e.g. captaining, operating equipment, etc).
6. Surveys shall be made prior to the start of work each day, and prior to resumption of work following any break of more than one half hour. Additional periodic surveys throughout the work day are strongly recommended.
7. All work shall be postponed or halted when ESA-listed marine species are within 50 meters (54.7 yards, 164 feet) of the proposed work, and will only begin/resume after the animals have voluntarily departed the area.
 - a. If ESA-listed marine species are noticed within 50 meters (54.7 yards, 164 feet) after work has already begun, that work may continue only if, in the best judgement of a biologist, the activity will not adversely affect (i.e. disturb or harm) the animal(s). For example: divers performing underwater work (excluding the use of toxic

⁴ NMFS staff are not available to serve as an observer.

chemicals) such as surveys would likely be permissible, whereas operation of heavy equipment is not.

8. Project-related personnel shall NOT conduct activities resulting in a take of an ESA-listed species, a species proposed for listing, or listed or proposed critical habitat. “Take” as defined under the ESA means “to harass, harm, pursue, hunt, shoot, wound, kill, trap, capture, or collect or attempt to engage in any such conduct”. Activities that would qualify as take include attempting to disturb, touch, ride, feed, or otherwise intentionally interact with any protected species.
9. Sensitive resource areas, such as corals, coral reefs and seagrass beds known to occur within a project area must be identified on project figures. Project staff must be instructed to avoid the sensitive resource areas to the greatest extent practicable, including avoiding anchoring in these areas, flagging the areas if appropriate, and securing all in-water equipment in a manner that will prevent the equipment from being dragged across the substrate.
10. Project construction must cease under unusual conditions, such as large tidal events and high surf conditions, except for efforts to avoid or minimize resource damage.
11. When a diver is involved in the action, the diver will do their best to avoid ESA-listed species. If an animal traverses within 50 m, however, the diver will take into account his/her own personal safety. The diver will report the interaction via the reporting requirement in BMP A 13.b.
12. If an ESA-listed species is adversely affected as a result of the project, all work must stop until coordination with the Corps and NMFS has been completed.
13. Reporting
 - a. Any monk seal sightings:
 - i. At the time of observation, the observer will report the sighting to the NOAA Statewide Hawaii Marine Wildlife Hotline at 888-256-9840. The observer will be prepared to provide information to the hotline operator about the sighting location and other site-specific information to help the operator determine the most appropriate response, if any.
 - ii. The observer will email documentation of Hawaiian monk seal sightings (e.g., photos, video, reports, etc.) to: pifsc.monksealsighting@noaa.gov, with the subject line indicated as: “Monk seal sighting documentation per Pac-SLOPES ESA section 7 consultation.” Documentation will always include the specific sighting location and the contact information of the reporting party.
 - b. Observer logs. All non-take interactions with listed species (e.g. a species entering the shut-down zone and work is shut down correctly) must be documented and reported to the Corps and NMFS in monitoring logs (Table 2 in Appendix B).
 - i. Monitoring logs shall be completed daily. If no ESA-listed species are observed, the observer will record “0” in the daily report.
 - ii. The monitoring logs will be submitted in a digital and queryable to the NMFS reporting contact(s) in Table 1.
 1. total hours and dates of monitoring

2. identification of which ESA species were observed and in what location and circumstances, including date, numbers of individuals of species observed, the outcome of the species observance relative to the authorized project, and any factors which may have affected visibility,
 3. if applicable, observed ESA species behaviors and movement types relative to the project activity at time of observation
- iii. All monitoring logs must be submitted to the NMFS within 90 calendar days of the completion of the project. The Corps will provide final reports to NMFS as part of the annual report. The final report will be comprised of summaries of monitoring efforts including:

B. BMPs for waste and discharge

1. A stormwater management plan, commensurate to the size of the project, must be prepared and carried out for any project that will produce any new impervious surface or a land cover conversion that will slow the entry of water into the soil to ensure that effects to water quality and hydrology are minimized.
2. An erosion control plan for the project site and adjacent areas must be prepared and carried out. Erosion controls must be properly installed before any alteration of the project area may take place.
3. A pollution control plan for the project site and adjacent areas must be prepared and implemented. At a minimum, this plan shall include:
 - a. Proper installation and maintenance of equipment diapers, or drip pans.
 - b. A contingency plan to control and clean spilled petroleum products, hydraulic leaks, and other toxic materials.
 - c. Appropriate materials to contain and clean potential spills will be stored at the work site and be readily available.
 - d. All project-related materials and equipment placed in the water will be free of pollutants.
 - e. Daily pre-work inspections of heavy equipment and vessels for cleanliness and leaks, with all heavy equipment operations and vessel use postponed or halted until leaks are repaired and equipment is cleaned.
 - f. Fueling of land-based vehicles and equipment shall take place at least 50 feet (15 meters) away from the water, preferably over an impervious surface.
 - g. All construction discharge water (e.g., concrete washout, pumping for work area isolation, vehicle wash water, drilling fluids) must be treated before discharge.
 - h. Debris and other wastes will be prevented from entering or remaining in the marine environment during the project.
4. Temporary access roads and drilling pads must avoid steep slopes, where grade, soil types, or other features suggest a likelihood of excessive erosion or failure; existing access routes must be utilized or improved whenever possible, in lieu of construction of new access routes.

5. Temporary fills must be removed in their entirety. All areas impacted by construction must be returned to pre-construction elevations. The affected areas must be stabilized and revegetated with native species as appropriate.
6. All disturbed areas must be immediately stabilized following cessation of activities for any break in work longer than 4 days.
7. Drilling and dredging are restricted to uncontaminated areas, and any associated waste or spoils must be completely isolated and disposed of in an approved upland disposal location.

C. BMPs for Activities that may result in Direct Physical Impact

1. Before any equipment, anchor(s), or material enters the water, a responsible party, i.e., permittee/site manager/project supervisor, shall verify that no ESA-listed marine animals are in the area where the equipment, anchor(s), or materials are expected to contact the substrate. If practicable, the use of divers to visually confirm that the area is clear is preferred.
2. Equipment operators shall employ “soft starts” when initiating work each day and after each break of 30 minutes or more that directly impacts the bottom. Buckets and other equipment shall be sent to the bottom in a slow and controlled manner for the first several cycles before achieving full operational impact strength or tempo.
3. All objects lowered to the bottom shall be lowered in a controlled manner. This can be achieved by the use of buoyancy controls such as lift bags, or the use of cranes, winches, or other equipment that affect positive control over the rate of descent.

D. BMPs for activities that may result in Entanglement

1. Temporary in-water tethers, as well as mooring lines for vessels and marker buoys shall be kept taut to the minimum length necessary, and shall remain deployed only as long as needed to properly accomplish the required task.
2. Mooring systems shall employ the minimum line length necessary to account for expected fluctuations in water depth due to tides and waves.
3. Mooring systems shall be designed to keep the line as tight as possible, with the intent to eliminate the potential for loops to form.
4. Mooring lines shall consist of a single line connected to the buoy float. No additional lines or material capable of entangling marine life may be attached to the mooring line or to any other part of the deployed system.
5. Mooring systems shall be designed to keep the gear off the bottom, by use of a mid-line float when appropriate.

6. Any permanent or long-term deployments shall include an inspection and maintenance program to reduce the likelihood of failures that may result in loose mooring lines lying on the substrate or hanging below a drifting buoy.
7. Mooring systems, including those used for temporary markers, scientific sensor buoys, or vessel moorings, shall be completely removed from the marine environment immediately at the completion of the authorized work or the end of the mooring's service life. The only exceptions to this rule shall be mooring anchors such as eyebolts that are epoxied into the substrate and which pose little or no risk to marine life.

E. BMPs for activities that may result in Exposure to Elevated Noise Levels

1. Maintenance dredging, in-water excavation, movement of large armor stones, and benthic core sampling shall not be undertaken if any ESA-listed marine animals are within 50 meters (54.7 yards, 164 feet) of the authorized work, and those operations will immediately shut-down if an ESA-listed marine animal enters within 50 meters (54.7 yards, 164 feet) of the authorized work. This condition is intended to ensure that no ESA-listed marine animals are exposed to sound levels anywhere near the TTS threshold isopleths.
2. Operation of buoy acoustic release systems shall cease when ESA-listed marine animals are within 250 meters (273 yards) (safety zone). It is further recommended that the permittee carefully survey the safety zone around the vessel/buoy from 30 minutes prior to activating the acoustic release, to 30 minutes following the end of transducer operations.

F. BMPs for activities that may result in Collision with Vessels:

1. When piloting vessels, vessel operators shall alter course to remain at least 100 meters (109 yards) from whales, and at least 50 meters (54.7 yards, 164 feet) from other ESA-listed marine animals.
2. Reduce vessel speed to 10 knots or less when piloting vessels in proximity of ESA-listed marine mammals, sharks, and rays.
3. Reduce vessel speed to 5 knots or less when piloting vessels in areas of known or suspected sea turtle activity.
4. If despite efforts to maintain the distances and speeds described above, a marine mammal or turtle approaches the vessel, the vessel operator will put the engine in neutral until the animal is at least 15 meters (~50 feet) away, and then slowly move away to the prescribed distance.
5. Marine mammals, sea turtles and other ESA-listed motile species shall not be encircled or trapped between multiple vessels or between vessels and the shore.
6. The Corps and NMFS contacts in Table 1 will be notified within 48 hours of a vessel grounding or abandonment during the proposed action.

G. Marina or Harbor Repair and Improvement Activities:

1. Repair and replacement of over-water and in-water structures (such as piers, docks, and launch ramps) under Pac-SLOPES is expressly limited to their existing footprints.
2. Replacement decking should be designed to reduce in-water shading to the greatest extent practicable.
3. Repair and removal work will be accomplished in a manner that minimizes the potential spread of invasive species that may reside on the pilings such as immediate removal from the water upon extraction or other appropriate approved containment methods.
4. Removed materials must be disposed of at an approved upland disposal site.

H. Piling Installation, Repair, Replacement and/or Removal:

1. Repair and removal work will be accomplished in a manner that minimizes the potential spread of invasive species.
2. Removed pilings must be disposed of at an approved upland disposal site.
3. Pac-SLOPES cannot be used if the distance to the TTS isopleth is greater than 50 m for sea turtles, 100 m for monk seals, 1000 m for cetaceans, or 250 m for sharks and rays. The Corps will provide calculations and details (including number of piles per day, minutes per pile, pile size, etc.) to NMFS to verify the distances to the TTS isopleths. Applicants can 1) use the publicly available User Spreadsheet tool available on the NMFS marine mammal sound calculator website (<https://www.fisheries.noaa.gov/national/marine-mammal-protection/marine-mammal-acoustic-technical-guidance>) to conduct their own analyses and have the Corps submit the spreadsheet and results to NMFS, or 2) the Corps may request technical assistance for help determining the TTS isopleths from NMFS as part of a Pac-SLOPES verification request. For non-Federal permit applicants, all analyses and information would be submitted to NMFS through the Corps as part of Pac-SLOPES verification. Should the applicant request technical assistance, the applicant must provide the following: pile size (diameter in inches), pile material (wood, concrete, or steel), number of piles installed within a 24-hour period, duration to drive a single pile (in minutes), water depth (feet or meters), and, if possible, the substrate type and type of vibratory hammer.

I. Installation and/or Repair of Buoys and Other Similar Structures:

1. Anchoring locations and moorings must be designed to avoid, to the greatest extent practicable, impacts to live corals, sea grass, and other benthic organisms.

2. Deployment of moored active acoustic devices must operate in frequency bands well outside the hearing ranges of ESA-listed marine animals (such as certain wave and current monitoring systems operating above 200 kHz), and moorings with acoustic release devices may only transmit a brief signal during deployment and during recovery of the mooring.
3. Should a mooring break free and ground, the permittee will notify the Corps about the grounding, including date and exact location. See Table 1 for Corps and NMFS reporting contact(s).

J. Maintenance Dredging:

1. With the exception of the actual dredging apparatus (e.g. clamshell buckets, or the scoop and articulated arm of a backhoe, hydraulic head, etc.), heavy equipment will be operated from above and out of the water.
2. Use of hydraulic dredging must include the installation of excluder devices adequate to prevent the entrainment or impingement of protected marine species such as sea turtles and juvenile scalloped hammerhead sharks.
3. The applicant will not use a Trailing Suction Hopper Dredge (or hopper dredge) to conduct dredging. There have been numerous observed mortalities of sea turtles and sharks associated with these vessels.
4. The applicant will not use Dustpan dredges, which use high velocity water jets to loosen material before sucking it into their apparatus. This technique causes high turbidity and the effects of water velocities from water jets to listed species have not been evaluated.
5. The applicant may use cutterhead dredges that are equipped with suction heads of 36 inches diameter or less, and a maximum intake velocity of 4.6 meters per second (15 feet per second), and an intake velocity of 95 cm per second (3.1 feet per second) at 1 meter away from the suction head.
6. The applicant may use pipeline dredges with openings no larger than 36 inches diameter, and intake velocities of 4.6 meters at the source and 95 cm per second at 1 meter. To avoid lethal entrainment or dismemberment of sea turtles, hammerhead sharks, or marine mammals, suction head openings larger than 12 inches must be either screened with 2-inch mesh or less, operated or monitored by a diver, or behind a barrier (e.g., coffer dams or silt curtains).
7. To minimize exposure to listed animals in the water column, the applicant will avoid moving the suction head through the water column while the pump is turned on. The applicant will turn on suction only when the suction heads are at the bottom and in contact with the sediment and turn it off before lifting the suction head up to the surface.

8. In known scalloped hammerhead shark nursery areas, the applicant will conduct all suction dredging behind barriers (e.g., coffer dams or silt curtains), or with a diver operating or monitoring the suction head and screening.
9. The portions of the equipment that enter the water will be clean and free of pollutants.
10. Appropriate silt containment devices must be used and properly installed to avoid degradation of adjacent coral reefs, and aquatic vegetation.
11. Dredged material must be deposited at upland sites, or at EPA designated ocean disposal sites provided sediment standards are met.

In the modified Blanket Water Quality Certification for the State of Hawaii 0901, dated November 30, 2020, General Condition f states “Ensure that pollution control measures and BMPs are utilized that prevent water pollutants from leaving the in-water work area authorized by the USACE [Corps] POH permit. Any visual plume emanating from the authorized in-water work area is a violation of HAR Chapter 11-54”.

K. Other Minor Discharges and Dredging/Excavations:

1. The dredged or discharged material will be free of contamination.
2. The site of excavation or discharge will contain no known forage or resting habitat for ESA-listed marine species.

L. Utility Line Installation and Repair:

1. Utility line placement location and method must be designed to avoid to the greatest extent practicable, impacts to live corals, submerged aquatic or marine vegetation and other benthic organisms, and wetlands.

M. Maintenance of Existing Bank Stabilization Structures:

1. No material will be discharged into special aquatic sites.
2. Bank stabilization will be limited to replacement within the current footprint only and will not extend waterward from the present site.
3. No new bank stabilization.
4. An activity will involve no more than 500 feet in total length along the bank.
5. The maximum amount of material placed shall not exceed the minimum needed for erosion protection.

6. No material is of a type, or is placed in any location, or in any manner, that will impair surface water flow into or out of any waters of the United States.
7. All material will be placed in a manner that will avoid erosion by normal or expected high flows.

N. Road Repairs and/or Improvements:

1. No new road construction.
2. Maximum road width shall be limited to the minimum width necessary.
3. Roads shall be designed and constructed in a manner that minimizes adverse impacts on surface and marine waters due to runoff and erosion, including adequate stormwater treatment. Erosion control BMPs will be checked daily during the construction period.
4. Roads shall be constructed as near as possible to pre-construction contours and elevations.
5. Roads must be bridged or culverts installed based on present or future (based on climate change data) 100-year flood flows, and in a manner that maintains surface flows with minimal modification to flow direction or velocity.

O. Bridge Repair and Replacement:

1. Temporary fills must consist of stable materials, and be placed in a manner, that will not be eroded by expected high flows.
2. Temporary fills must be removed in their entirety and the affected areas returned to pre-construction elevations within 30 days of project completion.

P. Stranded, Injured, Sick or Dead Marine Mammal or Turtle

1. If observers become aware of any injured, sick, or dead marine mammal or turtle (whether or not it may be related to the proposed action), they will immediately call the NOAA Statewide Hawaii Marine Wildlife Hotline at 888-256-9840. The observer will be prepared to provide information to the hotline operator about the animal's condition, location, and other information specific to the situation to help the operator determine the most appropriate response.
2. The observers will submit photos and data as soon as possible regarding stranded, injured, sick, or dead marine animals that NMFS may use to inform NMFS-directed field responses and/or further analysis to determine whether a taking resulted (see 3. below).. Photos and data submitted to NMFS regarding stranded, injured, sick, or dead marine animals will include date, time, location, species, and number of animals, as well as a description of the animal's condition, event type (e.g., entanglement, dead, floating), and behavior of live-stranded marine animals. The observers will email this documentation to: respectwildlife@noaa.gov, with the subject line indicated as: "Stranded animal information per Pac-SLOPES ESA section 7 consultation."

3. If NMFS responders determine the proposed action resulted in the taking, re-initiation of ESA consultation is warranted. The Corps will collect the following information and include it in the re-initiation request:
- Number of individuals and species of listed animals affected;
 - The date, time, and location of each event (provide geographic coordinates);
 - Description of the event;
 - The time the animal(s) was first observed or entered the shutdown zone, and, if known, the time the animal was last seen or exited the zone, and the fate of the animal;
 - Mitigation measures implemented prior to and after the take; and
 - If a vessel struck a marine mammal, the contact information for the observer on duty, or the contact information for the individual piloting the vessel if there was no observer on duty;
 - Photographs or video footage of the animal(s) (if available).

R. Contact Information

Table 1. Summary of agency contact information.

Reason for Contact	Contact Information
Consultation Questions	ESA email inbox (efhesaconsult@noaa.gov), and Consultation Biologist: @noaa.gov
Reports & Data Submittal (please include ECO tracking number in subject line)	efhesaconsult@noaa.gov , and CEPOH-RO@usace.army.mil
NOAA Fisheries Hawai'i Statewide Marine Stranding, Entanglement, and Reporting Hotline <i>(not related to project activities)</i>	Stranding Hotline (24/7 coverage): (888) 256-9840
Oil Spill & Hazardous Materials Response	U.S. Coast Guard National Response Center: 1-800-424-8802
Illegal Activities <i>(not related to project activities; e.g., feeding, unauthorized harassment, or disturbance to marine mammals)</i>	NMFS Office of Law Enforcement: 1-800-853-1964

NMFS Pacific Islands Regional Office	808-725-5000
Corps Honolulu District Regulatory Office	CEPOH-RO@usace.army.mil 808-835-4303

Instructions	
Data Attribute	Definition
Project Name	Indicate the name of the project.
Location	Specify the project location or observation station. This is extremely important if there are multiple observation stations.
Observer(s)	Indicate the observer(s) at the station during monitoring effort. If the observer(s) switch in the middle of the day indicate the time of the switch.
Agency record numbers	POH number for the Corps and the ECO number for NMFS PIRO
Project Activities	
Start and end times	Record start and end times of all in-water activities. Make sure to record breaks in any in-water activities. Military time is preferable.
Type of Activity	Specify the type of in-water activity and make sure to indicate specifics such as bubble curtain use. Types of activities may include soft-start, impact pile installation (w/ or w/o bubble curtain), vibratory pile installation or removal (w/ or w/o bubble curtain), down the hole drilling, dredging, vessel activity, anchor handling, fill placement, or other sources of in-water disturbance.
ESA-listed Animals Sighting	
Species	Identify the species observed. (FKW) false killer whale, (MS) monk seal, (UW) unidentified cetacean, (BW) blue whale, (FW) fin whale, (SEW) sei whale, (SPW) sperm whale, (NPRW) north pacific right whale, (HW) humpback whale, (HT) hawksbill sea turtle, (GT) green sea turtle, (OR) olive ridley sea turtle, (LHT) loggerhead sea turtle, (LBT) leatherback sea turtle, (SHS) scalloped hammerhead shark, (OWT) oceanic whitetip shark, (GR) giant manta ray, (AG) acropora globiceps, (ARE) A. retusa, (AS) A. speciosa, (EP) Euphyllia paradivisa, (IC), Isopora crateriformis.
Quantity	Document the number of animals seen per sighting (e.g. 1 turtle, 3 whales, etc.)

Behavior	<p>(T) traveling - moving in a linear or near-linear direction without interruption</p> <p>(M) milling - moving in a non-linear, weaving or circular pattern within an area</p> <p>(HO) hauled out - hauled out on land</p> <p>(D) diving - moving downward through the water column (rapidly or slowly), often showing tail fluke before dive</p> <p>(V) vocalizing - snorting, whistling, or chirping</p> <p>(BR) breaching - leaps clear out of water</p> <p>(SH) spyhopping - holding body vertically with head out of water for several seconds or more</p> <p>(ST) startled - rapidly changing behavior, dispersing or travelling that indicates a response to external event (must describe disturbance in the notes)</p> <p>(F) flush from haulout - enters water in response to disturbance (must describe disturbance in the notes)</p> <p>(CH) change direction - sudden change in direction that may be caused by disturbance (must describe in notes)</p> <p>(A) avoidance - avoiding an area (must describe in notes)</p> <p>(O) unclassified behavior (must describe in notes)</p> <p>(U) unknown - behavior indistinguishable due to monitoring conditions and/or lack of ability to watch marine mammal for length of time to determine (no comment is necessary)</p> <p>(S) sessile - for corals</p> <p>(All behavioral changes caused by the project activities or other activities must be described in the notes. Include a detailed description of activities/animal’s behavior before and after potential project related behavior change)</p>
Location (inside/outside shutdown zone) and duration	<p>Location – indicate if the species was inside or outside the shutdown zone.</p> <p>Duration – record the length of time if the ESA species was inside the shutdown zone.</p>
Action taken by project	<p>Indicate if a shutdown or delay was implemented due to marine mammals, sharks, rays, or sea turtles being observed.</p>
NOTES EXAMPLES	
Duration of Shutdown or Delay	<p>If a shutdown or delay occurred due to ESA-listed animal presence, indicate how long the shutdown or delay lasted.</p>
Sighting Notes	<p>Include any additional information, include specifics about ESA-listed animals behavioral changes from project activities.</p>

Table 2

Project Name:										
Location:										
Observer(s):										
Corps and NOAA Project numbers: POH-202 - -, PIRO-202 - -										
Date	Start time	End time	Activity type(s)	ESA-listed animal sighted	Quantity	Behavior	Location (i.e. inside/outside shutdown zone)	Duration	Action taken by project	No sightings this day
										<input type="checkbox"/>
										<input type="checkbox"/>
										<input type="checkbox"/>
										<input type="checkbox"/>
										<input type="checkbox"/>
										<input type="checkbox"/>
										<input type="checkbox"/>
Notes:										

EFH Conservation Recommendations

A. Conservation Recommendations for Physical Impacts to Benthic Communities

1. Equipment, anchors, structures, or fill shall not be deployed in project areas containing live corals, seagrass beds, or visible benthic organisms. Perform pre-deployment reconnaissance (e.g., divers, drop cameras, etc.) to ensure these resources are avoided.
2. Minimize direct impact (direct or indirect contact causing damage) by divers and construction related tools, equipment, and materials with benthic organisms, regardless of size, especially corals and seagrass.
3. Prevent trash and debris from entering the marine environment during the project.
4. Maintain all structures, gear, instrumentation, mooring lines, and equipment to prevent failures.
5. All objects lowered to the bottom shall be lowered in a controlled manner. Note: This can be achieved by the use of buoyancy controls such as lift bags, or the use of cranes, winches, or other equipment that affect positive control over the rate of descent. This often requires skilled in-water observation.
6. Select work platforms based on the following preferential hierarchy:
 - a. conduct all work from land or an existing structure;
 - b. use a barge with auto-positioning systems where thrusters will not cause increased turbidity;
 - c. anchor barges to (1) shoreline infrastructure; (2) nearby existing moorings; and, (3) anchors or spuds on sand only (as possible, have SCUBA divers lay anchors by hand in sand areas).
7. Ensure new structures minimize shading impacts to marine habitats. Note: Shade minimization measures include: maximizing the height of the structure and minimizing the width of the structure to decrease shade footprint; grated decking material; using the fewest number of pilings necessary to support the structures; and, aligning the boardwalk in a north-south orientation for the path of the sun to cross perpendicular to the length of the structure to reduce the duration of shading.
8. Mooring systems (e.g., buoys, chains, ropes) must:
 - a. be kept taut to the minimum length necessary.

- b. employ the minimum line length necessary to account for expected fluctuations in water depth due to tides or waves.
 - c. use a mid-line floats or other buoyancy devices to prevent contact with the ocean floor.
 - d. be properly maintained.
9. All temporary structures must be removed at the completion of construction and this timeframe will be defined as aligned with General Condition #30 of the Nationwide Permit Program.

B. Conservation Recommendations for Increase in Sedimentation and/or Turbidity

1. Appropriate silt containment devices must be properly installed, monitored and maintained.
2. Debris and sediment that is removed from the water shall be disposed of at an appropriate upland location. Sediment and debris must be contained while in transit or on the shore.
3. Project operations must cease under unusual conditions, such as large tidal events, storms, and high surf conditions.
4. Conduct intertidal work at low and/or slack tide to the greatest extent feasible.
5. To minimize impacts to coral larvae, you shall avoid in-water work during mass-coral spawning times or peak coral spawning seasons. Permittees shall coordinate with local NMFS Habitat Conservation Division representatives to determine the exact period when coral spawning would occur for the given year at the project site.
6. Maintain baseline water flow, volume, and velocity of the waterbody.
7. Use natural or bio-engineered solutions when feasible.
8. Fully stabilize disturbed upland areas prior to removing silt fences and erosion prevention measures.
9. Temporary fills must be removed in their entirety and the affected areas returned to pre-construction conditions and elevations.
10. Utilize environmental clamshell buckets for mechanical dredging.

C. Conservation Recommendations for Increase in Nutrients, Pesticides and Herbicides, Contaminants, and/or Freshwater

1. Conduct work during the dry season when possible; stop work during storms or heavy rains.
2. Prevent discharges into the water.
3. Inspect all equipment prior to beginning work each day to ensure the equipment is in good working condition, and there are no contaminant (e.g., oil, fuel) leaks. Work must be stopped until leaks are repaired and equipment is cleaned. Equipment should always be stored in appropriate staging area designed to be preventative in terms of containing unexpected spills when equipment is not in use or during fueling.
4. Fueling of project-related vehicles and equipment shall take place at least 50 feet, or the maximum distance possible, from the water and within a containment area, preferably over an impervious surface.
5. Use of treated wood⁸ that would be in contact with the water is not authorized.
6. Use diffusers on the end of subtidal discharge pipes to minimize impacts from discharges.
7. Prevent bentonite and other drilling fluids from contacting benthic organisms.

D. Conservation Recommendations for Increase in Acoustic Impacts

1. Use a vibratory hammer to install piles when possible. Under conditions where impact hammers are required, when possible, drive as deep as possible with a vibratory hammer prior to the use of an impact hammer.
2. Implement measures to attenuate the sound or minimize impacts to aquatic resources during pile installation. Methods to mitigate sound

⁸ Treated wood must exclude treatment using any chemicals and/or compounds that have been banned by the EPA or banned for use in marine waters of the U.S. by the EPA or local or state agency. Other chemicals and/or compounds used to treat wood of concern include, but are not limited to: copper-based treatments such as Ammoniacal copper zinc arsenate (ACZA) and Copper Chromium Arsenate (CCA), polycyclic aromatic hydrocarbons (PAHs) in creosote treated wood, borate, Propiconazole-Tebuconazole-Imidicloprid (PTI), sodium silicate, potassium silicate, fire-retardant based, and acetylated wood. For a list of chemicals that have been shown to negatively impact coral processes in the water column, see Nalley et al. (2021).

impacts include, but are not limited to, the following: surround the pile with a dewatered cofferdam and/or air bubble curtain system.

E.Conservation Recommendations for Increase in Invasive Species

1. Prior to in-water work, sanitize equipment or dive gear that has been previously used in an area known to contain invasive species.
 - a. In-water tool and dive gear (e.g., wetsuit, mask, fins, snorkel, BC, regulator, weight belt, booties) shall be disinfected by one of the following ways: a 1:52 dilution of commercial bleach in freshwater, a 3 percent free chlorine solution, or a manufacturer's recommended disinfectant-strength dilution of a quaternary ammonium compound in "soft" (low concentration of calcium or magnesium ions) freshwater.
 - b. Small boats that have been deployed in the field will be cleaned and inspected daily for organic material, including any algal fragments or other organisms. Organic material, if found, will be physically removed and disposed of according to the ship's solid-waste disposal protocol or in approved secure holding systems. The internal and external surfaces of vessels will be rinsed daily with freshwater and always rinsed and be allowed to dry before redeployment.

2. Vegetated areas impacted during construction must be revegetated with appropriate native species.

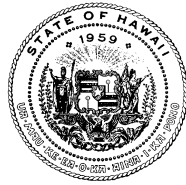

STATE OF HAWAII
DEPARTMENT OF HEALTH
P. O. BOX 3378
HONOLULU, HI 96801-3378

In reply, please refer to:
File:

WQC1092.FNL.22

April 28, 2022

David S. Hobbie
Regional Regulatory Chief
Honolulu District
Department of the Army
U.S. Army Engineer District, Honolulu
Fort Shafter, Hawaii 96858-5440

Dear Mr. Hobbie:

**Subject: Blanket Section 401 Water Quality Certification (WQC) for
Certain 2021 Department of the Army (DA)
Nationwide Permits (NWP) and Activities
File No. WQC1092**

Purpose. This letter is a blanket Section 401 WQC (Blanket Certification) and sets forth applicable qualifications and activity-specific conditions to certain NWPs and activities, as described below. This Blanket Certification may be utilized by any applicant that is seeking authorization and/or verification from the U.S. Army Corps of Engineers (USACE), Honolulu District of the Pacific Ocean Division (POH) for work in Waters of the United States.

This Blanket Certification supersedes and replaces previous WQC0901.FNL.20 issued in May and November of 2020 (WQC0901). The following shall apply:

1. Requirements and conditions set forth in WQC0901 which are not set forth in this Blanket Certification shall no longer be applicable;
2. Activities covered under WQC0901 shall be subject to this Blanket Certification, including requirements and conditions different from or in addition to WQC0901;
3. Pending applications, including those currently under review by USACE or the Department of Health (DOH), shall be subject to this Blanket Certification.

Note: A previous version of this Blanket Certification was public noticed on September 23 and 24, 2020, for the proposed 2020 NWPs. Since the aforementioned public notices, the NWPs were reissued and modified in 2021, the federal Section 401 WQC regulations were revised, and the State Section 401 WQC rules were revised. This Blanket Certification incorporates these revisions.

Overview. The DA has published a list of NWP's and applicable general conditions that attach to those NWP's.¹ Certain NWP's may require a Section 401 WQC from the State of Hawaii. The DOH has the authority to issue a Blanket Certification and may qualify or condition the Blanket Certification. The conditions in this Blanket Certification become additional conditions to the NWP's. The qualifications would set forth the applicability of the Blanket Certification to a NWP or other described activity.

The DOH reviewed the NWP and General Conditions published in the Federal Register: Final Rules and the additional comments submitted by USACE POH. DOH believes that when all requirements and conditions contained in this Blanket Certification are fully complied with, there is a reasonable assurance that the activities will be conducted in a manner which will not violate the applicable State water quality standards and will comply with the applicable provisions of the CWA, Sections 301, 302, 303, 306, and 307.

The NWP's and activities in Item 2.a below do not require a Section 401 WQC. The NWP's and activities in Item 2.b below are covered under this Blanket Certification. The DOH has determined that projects authorized by the USACE POH for the NWP's and activities in Item 2.b below, subject to the requirements of the General Conditions in Item 3 below, will not cause adverse environmental impacts or effects; are in the public interest; and represent the optimum balance between economic development and environmental quality.

1. Term of this Blanket Certification

- a. This Blanket Certification becomes effective with respect to a specific project on **April 28, 2022**.
- b. This Blanket Certification will expire at midnight, **March 14, 2026**.
- c. This Blanket Certification's coverage is administratively extended to a certain project beyond midnight, March 14, 2026, when the USACE POH extends the project authorization/verification.

2. Coverage of this Blanket Certification

- a. The NWP's and activities listed below do not require a Section 401 WQC.
 - NWP 1 – Aids to Navigation
 - NWP 8 – Oil and Gas Structures on the Outer Continental Shelf

¹ The DA NWP authorizes activities under 1) Section 404 of the Clean Water Act (CWA), 2) Section 10 of the Rivers and Harbors Act of 1899 (RHA), and/or 3) a Letter of Permission. The NWP's were published on September 15, 2020, in the Federal Register, Volume 85, Number 179 and December 27, 2021, Volume 86, Number 245 (Federal Register).

- Projects in response to a public emergency proclaimed by the President of the United States or Governor of Hawaii where HRS Chapter 342D has been suspended
 - Any emergency project as determined by the Director of Health
 - Projects granted an exemption under Act 048 of 2017 (temporary exemption of certain bridge rehabilitation projects)
 - Activities exempt under CWA, Section 404(f)(1)
 - Directional drilling under a waterbody where entry and exit pits are located on land and all slurry/spoils/runoff is contained on land
 - Structures over a waterbody where debris and other pollutants associated with the installation, construction, and operation do not enter the waterbody
 - Installation of temporary Best Management Practices (BMPs) with inert material in State waters, excluding material used to divert or dam stream flow
 - Comprehensive Environmental Response, Compensation, and Liability Act actions with oversight from DOH Hazard Evaluation and Emergency Response (HEER) Office and/or EPA
 - DOH HEER response actions
 - Bridge inspections
 - Improvements or modifications to Department of Land and Natural Resources, Division of Boating and Ocean Recreation permitted existing offshore moorings installed prior to October 4, 2017
 - Coral transplant with National Oceanic and Atmospheric Administration oversight
 - Fireworks where visible debris is collected after event
 - Lanterns and rubber duckies collected after event
 - Ashes from funeral ceremonies 3 miles away from shore
 - After-The-Fact applications for USACE POH enforcement actions²
- b. The NWP's and activities listed below are hereby granted coverage under this Blanket Certification in the State of Hawaii if the applicant of the activity/discharge complies with the General Conditions (Item No. 3) and USACE POH provides notification (Item No. 4). Any person, including any public body, conducting activities authorized by these NWP's and activities that cannot or will not comply with this Blanket Certification must apply for and obtain an individual Section 401 WQC from DOH Clean Water Branch (CWB).
- NWP 2 – Structures in Artificial Canals
 - NWP 3 – Maintenance

² DOH has decided not to process After-The-Fact applications so the USACE POH can proceed with their enforcement action.

- NWP 4 – Fish and Wildlife Harvesting, Enhancement, and Attraction Devices and Activities
- NWP 5 – Scientific Measurement Devices
- NWP 6 – Survey Activities
- NWP 7 – Outfall Structures and Associated Intake Structures
- NWP 9 – Structures in Fleeting and Anchorage Areas
- NWP 10 – Mooring Buoys
- NWP 11 – Temporary Recreational Structures
- NWP 12 – Oil or Natural Gas Pipeline Activities
- NWP 13 – Bank Stabilization
- NWP 14 – Linear Transportation Projects
- NWP 15 – U.S. Coast Guard Approved Bridges
- NWP 16 – Return Water from Upland Contained Disposal Areas
- NWP 17 – Hydropower Projects
- NWP 18 – Minor Discharge
- NWP 19 – Minor Dredging
- NWP 20 – Response Operations for Oil or Hazardous Substances
- NWP 22 – Removal of Vessels
- NWP 23 – Approved Categorical Exclusions
- NWP 25 – Structural Discharges
- NWP 27 – Aquatic Habitat Restoration, Establishment, and Enhancement Activities
- NWP 28 – Modifications of Existing Marinas
- NWP 29 – Residential Developments
- NWP 31 – Maintenance of Existing Flood Control Facilities
- NWP 32 – Completed Enforcement Actions
- NWP 33 – Temporary Construction, Access and Dewatering
- NWP 35 – Maintenance Dredging of Existing Basins
- NWP 36 – Boat Ramps
- NWP 37 – Emergency Watershed Protection and Rehabilitation
- NWP 38 – Cleanup of Hazardous and Toxic Waste
- NWP 39 – Commercial and Institutional Developments
- NWP 40 – Agricultural Activities
- NWP 41 – Reshaping Existing Drainage Ditches
- NWP 42 – Recreational Facilities
- NWP 43 – Stormwater Management Facilities
- NWP 45 – Repair of Uplands Damaged By Discrete Events
- NWP 46 – Discharges in Ditches
- NWP 48 – Commercial Shellfish Mariculture Activities
- NWP 51 – Land-Based Renewable Energy Generation Facilities
- NWP 53 – Removal of Low-Head Dams
- NWP 54 – Living Shorelines

- NWP 55 – Seaweed Mariculture Activities
- NWP 56 – Finfish Mariculture Activities
- NWP 57 – Electric Utility Line and Telecommunications Activities
- NWP 58 – Utility Line Activities to Water and Other Substances
- NWP 59 – Water Reclamation and Reuse Facilities
- Letters of Permission – Section 10 only activities with no discharge of fill material
- Any activity conducted in compliance with DOH pre-approved Standard Operating Procedures

c. Limitations on Coverage

This Blanket Certification shall not cover:

- (1) Discharge(s) regulated under CWA, Section 402.
- (2) Any project that may result in downstream/downdrift post construction impacts to the physical, chemical, and/or biological environment.
- (3) Concrete lining any section of natural streambed or bank.³
- (4) Projects involving the removal of dams, impoundments, structures, or sand bars that will result in the downstream/downdrift mobilization of material, sediment, and/or water pollutants.
- (5) Waste Discharges to natural lakes and anchialine pools as specified in HAR 11-54 or any State waters.
“Waste” means sewage, industrial and agricultural matter, and all other liquid, gaseous, or solid substance, including radioactive substance, whether treated or not, which may pollute or tend to pollute the waters of this State. Hawaii Revised Statutes (HRS) §342D-1.
Non-contaminated and suitable dredge and fill material authorized under a 2021 NWP is not considered waste.
- (6) New sewage discharges and new industrial discharges to estuaries as specified in HAR 11-54. New industrial discharges do not include the repair and/or replacement within the footprint of an existing structure.
- (7) New sewage and industrial discharges to Embayments: Class AA and Class A as identified in HAR 11-54. New industrial discharges do not include the repair and/or replacement within the footprint of an existing structure.

³ This type of activity is prohibited as it will result in adverse post construction impacts by eliminating ground water recharge, raising pH, and lowering dissolved oxygen or causing downstream bank erosion.

3. General Conditions

The applicant of the activity/discharge shall:

- a. Report any non-compliance with the conditions of this Blanket Certification to the USACE POH. Do not report or submit compliance related information to DOH. This Blanket Certification is a condition of the USACE POH permit.⁴
- b. Maintain records at the project site or in the nearby field office demonstrating that all Blanket Certification requirements have been fully complied with.
- c. Ensure that all activities are conducted in a manner that will comply with the "Basic Water Quality Criteria Applicable to All Waters" as specified in HAR 11-54.
- d. Ensure that all material(s) placed or to be placed in State waters are free of waste metal products, organic materials, debris, and any pollutants at toxic or potentially hazardous concentrations to aquatic life as specified in HAR 11-54.
- e. Ensure that the activities will not permanently interfere with or become injurious to any designated uses and/or existing uses of the receiving State water. Any permanent adverse impacts to the designated uses and/or existing uses of the receiving State water is a violation of HAR Chapter 11-54.
- f. Ensure that pollution control measures and BMPs are utilized that prevent water pollutants from leaving the in-water work area authorized by the USACE POH permit.⁵ Any visual plume emanating from the authorized in-water work area is a violation of HAR Chapter 11-54.
- g. Ensure that all construction debris from any portion of the activities (including but not limited to debris caused by hydraulic saws, water jets, or drilling equipment) are contained and prevented from entering or re-entering State waters. All construction debris and sidecast material shall be properly removed from the aquatic environment and disposed of at an upland State and county approved site. Before the start of the activities, a Solid Waste Disclosure Form for Construction Sites shall be completed and returned to the DOH's Solid and Hazardous Waste Branch,

⁴ With respect to USACE projects granted coverage under Item 2.c above, non-compliance reports from USACE POH should be submitted to DOH CWB.

⁵ With respect to USACE projects granted coverage under Item 2.c above, the relevant in-water work area is identified in the USACE project.

Office of Solid Waste Management. No construction material or construction related materials shall be stockpiled in the aquatic environment or stored or placed in ways that will disturb the aquatic environment. The Solid Waste Disclosure Form for Construction Sites is available online at:

<https://health.hawaii.gov/shwb/files/2018/04/swdiscformapr2018.pdf>.

- h. Utilize only BMPs that are inert and not sources of pollution themselves. Examples of inappropriate in-water porous material BMPs include but are not limited to: compost biosocks since they are a source of nutrients; and a soil berm since the soil particles will erode.
- i. Collect activity/discharge related water pollutants utilizing appropriate catchment/detention devices (e.g. construction debris, airborne particulates, dust, concrete slurry, concrete chips, concrete surface preparation washing effluent, excess water and overflow from boring related activity, horizontal directional drilling slurry, etc.) from localized work areas and minimize or prevent the release of these water pollutants into State waters, including the in-water work area.
- j. Utilize BMPs for all upland project activity to minimize the discharge of water pollutants into State waters, including the designated in-water work area.
- k. For a stream, ditch, or gulch: Allow unimpeded flow around the in-water work area to allow for aquatic animal migration and/or to prevent work site and downstream flooding situations. The unimpeded flow shall be equivalent to a 2-year, 24-hour duration storm event and/or the existing flow capacity of the stream, ditch, or gulch. Pumped diversions may be utilized if the stream, ditch, or gulch is dry or there is only standing/ponded water without the existence of living aquatic animals.
- l. Not discharge any type of wash water and/or effluent into State waters without first obtaining from DOH a National Pollutant Discharge Elimination System (NPDES) permit authorizing such type of water pollutant discharge to State waters.
- m. Not allow any concrete truck wash water to be disposed by percolation into the ground.
- n. Ensure that all areas temporarily impacted, either directly or indirectly, by the project construction activities are fully restored to its pre-construction conditions. For example: Incidental construction debris is cleaned up prior to removal of BMPs; remove all scientific measurement devices and any other structures or fills associated with installation and use of these

devices (e.g., foundations, anchors, buoys, lines, etc.) when no longer in use; etc.

- o. When projects involve dredging/excavation activities:
- (1) Be required to check the DOH, HEER Office Sites, Incidents and Records through the “Viewer” in iHEER at:
<https://eha-cloud.doh.hawaii.gov/iheer>.⁶
 - (2) Be required to contact the HEER Office at (808) 586-4249 and through e-permitting Form “Notification of Construction Activities” at Form Finder <https://eha-cloud.doh.hawaii.gov/epermit/finder> if contaminated soil, sediment, vapor, or groundwater is known to be present at your project site. The applicant shall notify the HEER Office at least 90 days prior to surface and subsurface disturbing activities that may disturb the ground surface at HEER sites. If the 90-days prior notification is missed, the applicant shall notify the HEER Office as soon as possible to avoid any potential delays regarding the covered project.
 - (3) Contain return flow or runoff from upland dredged spoils dewatering site(s)/disposal site(s), including the confined disposal facility (CDF), which shall be contained on land and not allowed to discharge and/or re-enter any State waters without first obtaining the required discharge permit from USACE POH or CWB. Unless authorized by a USACE POH or NPDES permit, the applicant shall not allow any runoff, return flow, or airborne particulate pollutants from the excavated or dredged material dewatering or stockpiling site, including the CDF, to enter or re-enter State waters.
 - (4) Properly deploy warning signs, which shall be maintained until the portion of the in-water work is completed and the affected area water quality has returned to its preconstruction condition and turbidity control devices have been removed from the waterway.
- p. When projects involve moorings:
- (1) Avoid locating moorings (including anchors and floats) in sensitive aquatic habitats such as coral reefs, fish spawning areas, and submerged aquatic vegetation (unless location is acceptable to the Department of Land and Natural Resources, Division of Aquatic Resources or the National Oceanic Atmospheric Administration);
 - (2) Ensure moorings (including anchors and floats) are made of clean, inert material. Treated lumber shall not be used as it may contain

⁶ The HEER Office is currently updating site information for sites. Most, but not all, sites may be displayed on the viewer map. Site Document data upload is ongoing and not all documents may be currently available via this website. To get the complete record for the site, a record request form can be filled and submitted to the HEER Office. Users will then be notified when they are able to download all information via the iHEER system website.

- compounds that can be released into the water and become toxic to the aquatic environment;
- (3) Pre-cast and cure concrete anchors, if required, away from State waters prior to use to prevent seepage of potentially toxic substances into the waterbody;
 - (4) Locate moorings in depths that allow structures and vessels to remain afloat at the lowest possible water levels and that prevent propellers from disturbing bottom sediments;
 - (5) Select mooring anchors of an adequate size to secure vessels or structures and prevent the anchor from shifting or dragging along the bottom of the State water;
 - (6) Size the length of mooring lines, chains, or cables to avoid excess line, chain, or cable accumulation on the bed of the State water;
 - (7) Ensure native beach material such as logs, sand, gravel, and boulders that are important components of fish habitat are not used as mooring structures and are left in place on the foreshore;
 - (8) Properly dispose of derelict or unused floats, lines, chains, or cables in accordance with appropriate laws and rules; and
 - (9) Ensure moorings are kept in good repair by regularly inspecting and maintaining the structure. Mooring maintenance must be performed into perpetuity (or until it is properly disposed of) or it will itself become a pollution source.
4. USACE POH shall e-mail to CWB (cleanwaterbranch@doh.hawaii.gov and darryl.lum@doh.hawaii.gov) a pdf copy of all issued final verifications. This Blanket Certification coverage shall become valid with respect to an activity only when USACE POH notifies CWB via email of a project authorization/verification and conditions of this Blanket Certification have been incorporated as part of the USCE POH final verification; provided, that this email notification requirement shall not apply to activities that do not require a pre-construction notification, and this Blanket Certification shall automatically become valid with respect to such activities.

Mr. David S. Hobbie
April 28, 2022
Page 10

WQC1092.FNL.22

If you agree with the terms and conditions of this Blanket Certification, please sign and date below; make a copy for your administrative record; and submit this entire letter with your original signature to CWB within 14 calendar days from your signature date.

If you have any questions, please contact Mr. Darryl Lum of the Engineering Section, CWB, at (808) 586-4309.

Sincerely,

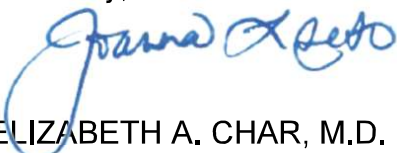
for
ELIZABETH A. CHAR, M.D.
Director of Health

- c: Regulatory Office, POH, COE [via e-mails linda.speerstra@usace.army.mil only]
- Ms. Debra Mendes, CZM Program, Office of Planning, DBEDT
[via e-mail debra.l.mendes@hawaii.gov only]
- U.S. Fish and Wildlife Service [via e-mail pifwo_admin@fws.gov only]
- U.S. National Marine Fisheries Service [via e-mail pirohonolulu@noaa.gov only]
- Division of Aquatic Resources, DLNR [via e-mail dlnr.aquatics@hawaii.gov only]
- CWRM, DLNR [via e-mail dlnr.cwrn@hawaii.gov only]
- OCCL, DLNR [via e-mail dlnr.occl@hawaii.gov only]
- DHO (Hawaii, Maui, Kauai) and EHS, Molokai/Lanai [via e-mail only]

I AGREE WITH THE TERMS AND CONDITIONS OF THIS LETTER:

David S. Hobbie
Regional Regulatory Chief
Honolulu District

DATE



US Army Corps of Engineers
Honolulu District
BUILDING STRONG[®]

DEPARTMENT OF THE ARMY PERMIT COMPLIANCE CERTIFICATION

File Number: POH-2016-00220

Project Title: DLNR, Mala Boat Ramp Maintenance Dredging, Lahaina, Island of Maui, Hawaii

PERMIT TYPE: Nationwide Permit #35, (Maintenance Dredging of Existing Basins)

NAME OF PERMITTEE: Ms. Meghan Statts, DLNR DOBOR, 4 Sand Island Access Road, Honolulu, HI 96819

DATE OF ISSUANCE: January 23, 2025

DATE OF EXPIRATION: March 14, 2026

The permittee must, upon completion of the activity authorized by this permit and any mitigation required by the permit, sign this certification and return it to the following address or via email within thirty (30) days of completion of work:

U.S. Army Corps of Engineers, Honolulu District
Regulatory Office
Building 230, CEPOH-RO
Fort Shafter, HI 96858-5440
Email: CEPOH-RO@usace.army.mil

Please note that your permitted activity is subject to a compliance inspection by a U.S. Army Corps of Engineers representative. If you fail to comply with the terms and conditions of this permit, you are subject to permit suspension, modification or revocation.

I hereby certify that the work authorized by the above referenced permit has been completed in accordance with the terms and conditions of the said permit, and required mitigation was completed in accordance with the permit conditions.

Signature of Permittee

Date