

State of Hawaii
DEPARTMENT OF LAND AND NATURAL RESOURCES
ENGINEERING DIVISION
1151 Punchbowl Street, Room 221
Honolulu, Hawaii 96813

ADDENDUM NO. 1

TO
Job No. F55C642D
Waianapanapa State Park, Walkway Improvements
Hana, Maui, Hawaii

January 29, 2016

The items listed hereinafter are hereby made a part of the contract for the above project and shall govern the work, taking precedence over previously issued plans and specifications governing the items mentioned.

SPECIFICATIONS

1. Notice to Bidders –9th paragraph, DELETE entire paragraph and replace with:

"Vendors are required to be compliant with all or the requirements of 103D-310(c)."
2. Proposal – DELETE in its entirety and REPLACE with the attached revised Proposal.
3. Section 01019 – General Specifications, Part 1, Section 1.2.E, Contractor's Operation, DELETE in its entirety and REPLACE with:

"E. Contractor's Operations
 - 1 The park will be open to the public during construction. The Contractor must employ, insofar as possible, such methods and means of carrying out the work so as not to cause any interruption or interference to the facility's operations. Where the Contractor's operations would result in interruptions which would hamper the operations of the facilities, the Contractor shall rearrange the schedule of work accordingly.
 2. The Contractor shall maintain safe passageway to and from the facility for the user agency personnel and the public at all times.
 3. All construction work within the park shall be completed within **180 consecutive days**.
 4. There are a total of 12 rental cabins within the park that sleeps 6. One cabin will be made available to the Contractor at a cost of \$60 per night during the 180 consecutive-day construction period to be used for lodging only.

5. The Contractor shall keep their cabin in a neat and clean state at all times.
 6. The Contractor shall ensure that all workers employed on the project by the Contractor or by his subcontractor and who are staying in the cabin respect the property, other cabin guests, and follow the rules and regulations set forth in HAR 13-146. "
2. Section 05500 - Miscellaneous Metal Fabrications, DELETE in its entirety and REPLACE with the attached revised Section 05500.
 3. Add new Section 05522 – Stainless Steel Pipe Railings. See attached.

PLANS:

SHEET	SHEET NAME OR DESCRIPTION
C-3	Replace sheet with attached revised drawing
C-4	Replace sheet with attached revised drawing
C-5	Replace sheet with attached revised drawing

GENERAL INFORMATION

1. A pre-bid meeting was held on November 18, 2014. The pre-bid meeting minutes and sign-in sheet are attached for information only.
2. Question: In the bid proposal, Item #13 and Item #18 are both line items for the project sign. When submitting the bid will the project sign be calculated in twice for the total base bid price?

Response: Project Sign duplicate was corrected. See Addendum No. 1 for revised Proposal.
3. Question: In the proposal, Bid Item #9 description calls for concrete benches. The plan only depicts recycled plastic benches. Could you please clarify for bidding purposes which type benches, concrete or recycled plastic, will be installed?

Response: Should be recycled plastic benches. See Addendum 1 for revised Proposal.

Engineering Division

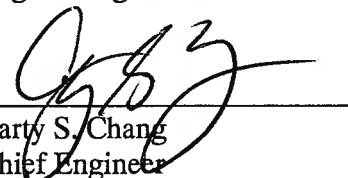
Carty S. Chang
Chief Engineer

PROPOSAL

FOR

DEPARTMENT OF LAND AND NATURAL RESOURCES
ENGINEERING DIVISION
State of Hawaii

Job No. F55C642D
WAIANAPANAPA STATE PARK, WALKWAY IMPROVEMENTS
HANA, MAUI, HAWAII

_____, 20__

Chief Engineer
Engineering Division
Department of Land and Natural Resources
State of Hawaii
Honolulu, Hawaii

Dear Sir:

The undersigned, having carefully examined the local conditions and all available records and information covering conditions which may affect the cost of the work to be performed, and having carefully examined the Plans and Specifications, and other contract documents, hereby proposes to furnish and pay for all materials, tools, equipment, labor and other incidental work necessary to remove and replace hard-surface paths, stairs, and railings, and construct a new boardwalk, as required or called for in this Proposal, all according to the true intent and meaning of the Notice to Bidders, Information and Instructions to Bidders, Proposal, Detailed Specifications, Interim General Conditions, Plans, and any and all addenda for:

Job No. F55C642D
WAIANAPANAPA STATE PARK, WALKWAY IMPROVEMENTS
HANA, MAUI, HAWAII

on file in the office of the Engineering Division for the TOTAL BASE BID (Items 1 to 19) of:

_____ Dollars (\$ _____)

and will fully complete all work under this contract within 270 consecutive calendar days from the date of written notice to proceed, including date of said order, said total sum being itemized on the following pages.

PROPOSAL

Item No.	Quantity	Unit	Description	Unit Price	Total
1.		L.S.	Erosion Control		\$
2.		L.S.	Demolition, Hauling and Disposal		\$
3.		L.S.	Clearing & Grubbing		\$
4.		L.S.	Grading		\$
5.		L.S.	Tree Root Removal, Root Barrier Installation		\$
6.		L.S.	Tree Removal		\$
7.	6,040	S.F.	Concrete Walkway	\$	\$
8.	1,070	S.F.	Concrete Stairs	\$	\$
9.	3	EA.	Bench	\$	\$
10.		L.S.	Retaining Wall		\$
11.		L.S.	Grassing		\$
12.		L.S.	Stainless Steel Pipe Railing		\$
13.	895	L.F.	Three-Rail Barricade	\$	\$
14.		L.S.	Boardwalk		\$
15.		L.S.	Extend Cemetery Rock Wall		\$
16.		L.S.	Re-Build Rock Wall		\$
17.		L.S.	Project Sign		\$
18.	Allowance		Field Office		\$ 10,000.00
			Subtotal Base Bid (Items 1-18)		\$
19.		L.S.	Mobilization and Demobilization (not to exceed 10% of the Subtotal Base Bid)		\$
			Total Base Bid (Items 1-19)		\$

HAWAII PRODUCTS PREFERENCE AND/OR USE OF HAWAII PRODUCTS

In accordance with Act 175, SLH 2009, the Hawaii products preference is applicable to this solicitation. Bidders offering a Hawaii product (“HP”) shall identify the HP in the table below.

Persons desiring to qualify their product(s) not currently on the Hawaii Product List, shall complete Form SPO-38, *Certification for Hawaii Product Preference*, and submit the completed form no later than the deadline specified in the procurement notice and solicitation. The responsibility for certification and qualification shall rest upon the person requesting the preference. One form shall be completed and submitted for each product. Form SPO-38 is available at <http://hawaii.gov/spo/>.

For the purpose of selecting the low bid when a solicitation contains both HP and non-HP, the price offered for a HP item shall be decreased by subtracting 10% for the class I or 15% for the class II HP item(s) offered. The lowest total offer, taking the preference into consideration, shall be awarded the contract, unless the offer provides for additional award criteria. The contract amount of any contract awarded, however, shall be the amount of the price offered, exclusive of the preferences.

In the event of any change that materially alters the bidder’s ability to supply the Hawaii product(s), the bidder shall immediately notify the procurement officer in writing and the parties shall enter into discussions for the purpose of revising the contract or terminating the contract for convenience.

Item No.	Pre-Approved Hawaii Product Description & Manufacturer	Class (I or II)	Quantity	Unit Measure	Unit Price	Total Price
1.	<i>[Product Description, Manufacturer Name]</i>	(I)				
2.						
3.						
4.						

RECYCLED PRODUCTS PREFERENCE

This project allows a 10% price preference for recycled products in accordance with HRS 103D-1005. Please indicate your recycled or non-recycled product by indicating its cost FOB jobsite unloaded in the schedule below, including applicable General Excise & Use Taxes.

<u>DESCRIPTION</u>	<u>RECYCLED PRODUCT COST</u>	<u>NONRECYCLED PRODUCT COST</u>
_____	\$ _____	\$ _____
_____	\$ _____	\$ _____
_____	\$ _____	\$ _____
_____	\$ _____	\$ _____

The bidder requesting a recycled product preference shall also complete and submit the form "CERTIFICATION OF RECYCLED CONTENT" as shown in the Interim General Conditions and provide all supporting information with this proposal. Additional information may be requested to qualify a product.

The following definitions are applicable to the CERTIFICATION OF RECYCLED CONTENT form:

"Post-consumer recovered material" means any product used by a consumer, including a business that purchases the material, that has served its intended end use, and that has been separated or diverted from the solid waste stream for the purpose of use, reuse, or recycling.

"Product" includes materials, manufactures, supplies, merchandise, goods, wares, and foodstuffs.

"Recovered material" means waste material and by-products that have been separated, diverted, or removed from the solid waste stream after a manufacturing process for the purpose of use, reuse, or recycling. Recovered material does not include those materials and by-products that are generated and normally reused on-site or within original manufacturing processes (such as mill broke, in the case of paper products).

"Recycled content" means the percentage of a product composed of recovered material, or post-consumer recovered material, or both.

"Recycled product" means a product containing recovered material, or post-consumer recovered material, or both.

The bidder agrees that preference for recycled products shall be taken into consideration to determine the low bidder in accordance with said Section and the rules promulgated, however, the award of contract will be in the amount of the bid offered exclusive any preference.

APPRENTICESHIP AGREEMENT PREFERENCE

1. If applicable to this project, any bidder seeking the preference must be a party to an apprenticeship agreement registered with the State Department of Labor and Industrial Relations (DLIR) at the time the bid is submitted for each apprenticeable trade the bidder will employ to construct the project. "Employ" means the employment of a person in an employer-employee relationship.
 - a. The apprenticeship agreement shall be registered with the DLIR and conform to the requirements of Hawaii Revised Statutes Chapter 372.
 - b. Subcontractors do not have to be a party to an apprenticeship agreement for the bidder to obtain preference.
 - c. The bidder is not required to have apprentices in its employ at the time the bid is submitted to qualify for the preference.
2. A bidder seeking the preference must state the apprenticeable trade the bidder will employ for each trade to be employed to perform the work by submitting a completed signed original Certification Form 1 verifying participation in an apprenticeship program registered with DLIR. "Apprenticeable trade" shall have the same meaning as "apprenticeable occupation" pursuant to Hawaii Administrative Rules (HAR) §12-30-5.
 - a. The *Certification Form 1* shall be authorized by an apprenticeship sponsor listed on the DLIR list of registered apprenticeship programs. "Sponsor" means an operator of an apprenticeship program and in whose name the program is approved and registered with the DLIR pursuant to HAR §12-30-1.
 - b. The authorization shall be an original signature by an authorized official of the apprenticeship sponsor.
 - c. The completed signed original Certification Form 1 for each trade must be submitted with the bid. Previous certifications shall not apply.
 - d. When filling out the *Certification Form 1*, the name of Apprenticeable Trade and Apprenticeship Sponsor must be the same as recorded in the List of Construction Trades in Registered Apprenticeship Programs that is posted on the DLIR website. "Registered apprenticeship program" means a construction trade program approved by the DLIR pursuant to HAR §12-301 and §12-30-4.
 - e. The *Certificate Form 1* and the List of Construction Trades in Registered Apprenticeship Programs is available on the DLIR website at: <http://hawaii.gov/labor/wdd>.
3. Upon receiving the *Certification Form 1*, the Procurement Officer will verify that the apprenticeship program is on the List of Construction Trades in Registered Apprenticeship Programs and that the form is signed by an authorized official of the Apprenticeship Program Sponsor. If the programs and signature are not confirmed by the DLIR, the bidder will not qualify for the preference.
4. If the bidder is certified to participate in an apprenticeship program for each trade which will be employed by the bidder for the project, a preference will be applied to decrease the bidder's bid

amount by five percent (5%) for evaluation purposes.

5. Should the bidder qualify for other preferences (e.g. Hawaii Products), all applicable preferences shall be applied to the bid price.

CONTRIBUTIONS BY STATE AND COUNTY CONTRACTORS PROHIBITED

Contractors are hereby notified of the applicability of Section 11-355, HRS, which states that campaign contributions are prohibited from specified State or county government contractors during the term of the contract if the contractors are paid with funds appropriated by a legislative body.

CONDITION OF AWARD

It is understood that the award of the contract will be made on the basis of the lowest responsible Total Base Bid (Items 1 to 19) selected by the Board of Land and Natural Resources. Write the total of bid items 1 to 19 on page P-1.

In the event the low bid is below the available funds certified by the appropriate fiscal officer, the head of the purchasing agency responsible for the procurement in question is authorized to award Additives to the lowest bidder. The award of Additives may be in any order or combination such that the Base Bid plus Additives do not exceed the available funds.

It is understood and agreed that the Board of Land and Natural Resources reserves the right to reject any and/or all bids and waive any defects when, in the Board's opinion, such rejection or waiver will be for the best interest of the State of Hawaii.

In the event all bids exceed available funds certified by the appropriate fiscal officer, the head of the purchasing agency responsible for the procurement in question is authorized in situations where time or economic considerations preclude resolicitation of work of a reduced scope to negotiate an adjustment of the bid price, including changes in the bid requirements, with the low responsible and responsive bidder, in order to bring the bid within the amount of available funds. It is understood and agreed upon that the head of the purchasing agency may delete a portion or all of any item(s) in the proposal at the stated unit or lump sum price as necessary to stay within the available funding. The bidder is responsible to make an earnest effort to represent the actual cost of each item, including all materials, labor, equipment, overhead and profit in their bid proposal to preclude claims of anticipated profit or loss of profit because of an unbalanced bid proposal.

It is also understood that if a mutually agreeable cost for the reduced scope of work necessitated by a lack of available funds cannot be agreed upon between the bidder and the head of the purchasing agency within 14 calendar days after the bid opening, then the bid may be rejected in the best interest of the purchasing agency, and the head of the purchasing agency may negotiate in progressive order (lowest to highest) with the next lowest responsible and responsive bidder.

It is also understood and agreed that the award of the contract shall be conditioned upon funds being made available for this project and further upon the right of the Board of Land and Natural Resources to hold all bids received for a period of sixty (60) days from the date of the opening thereof, unless otherwise required by law, during which time no bid may be withdrawn.

It is also understood that Notice to Proceed may be delayed up to one (1) year after the bid opening date, and that no additional compensation will be provided for any claim for escalation or delay for issuance of Notice to Proceed on or before that date.

It is also understood and agreed that the quantities given herewith are approximate only and are subject to increase or decrease, and that the undersigned will perform all quantities of work as either increased or decreased, in accordance with the provisions of the Contract Specifications.

It is also understood and agreed that the estimated quantities shown for the items for which a UNIT PRICE is asked in this Proposal are only for the purpose of comparing on a uniform basis, bids offered for the work under this contract, and the undersigned agrees that he is satisfied with and will at no time, dispute said estimated quantities as a means of claims for anticipated profit or loss of profit, because of a difference between the quantities of the various classes of work done or the materials and equipment installed, and the said estimated quantities. On UNIT PRICE bids, payment will be made only for the actual number of units incorporated into the finished project at the contract UNIT PRICE.

After the proposals are opened and read, the figures will be extended and/or totaled in accordance with the bid prices of the acceptable proposals and the totals will be compared. In the comparison of bids, words written in the proposal shall govern over figures and unit prices will govern over totals. Until the award of the contract, however, the right will be reserved to reject any and all proposals and to waive any defects or technicalities as may be deemed best for the interest of the State.

It is also understood and agreed that liquidated damages in the amount of Two Hundred and No/100 (\$ 200.00) for each and every calendar day in excess thereof prior to completion of the contract shall be withheld from payments due to the Contractor.

It is also understood and agreed that if this bid is accepted, the successful bidder must enter into and execute a contract with the Board of Land and Natural Resources and furnish a Performance and Payment Bond, as required by law. These bonds shall conform to provisions of Section 103D-324 and 325, Hawaii Revised Statutes and any law applicable hereto.

It is also understood and agreed that the successful bidder will provide all necessary labor, materials, tools, equipment, and other incidentals necessary to do all the work and furnish all the materials specified in the contract in the manner and time herein prescribed, and according to the requirements of the Engineer as therein set forth.

It is understood that by submitting this proposal, the undersigned is declaring that his firm has not been assisted or represented on this matter by an individual who has, in a State capacity, been involved in the subject matter of this contract in the past two years.

It is understood that by submitting this proposal in accordance with HAR 3-122-192, the undersigned is declaring that the price submitted is independently arrived without collusion.

It is also understood that by submitting this proposal, a Certification for Safety and Health Programs for bids in excess of \$100,000 (in accordance with HRS 396-18), the undersigned certifies that his organization will have a written safety and health plan for this project that will be available and implemented by the Notice to Proceed date of this project. Details of the requirements of this plan may be obtained from the Department of Labor and Industrial Relations, Occupational, Safety and Health Division (HIOSH).

It is further understood and agreed that the successful bidder shall comply with paragraph 3.1.a "SUBCONTRACTING" of the General Provisions which requires that the contractor shall perform with his own organization and with the assistance of workmen under his immediate superintendence, work of a value not less than twenty percent (20%) of the value of all work embraced in the Contract, except that certain contract items of work, if specifically referred to in the special provisions, will be exempted from said twenty percent requirement.

Compliance with §103-310 HRS. As a condition of award all bidders shall comply with all laws governing entities doing business in the State, including Chapter 237 HRS (general excise tax); Chapter 383 HRS (employment security – unemployment insurance); Chapter 386 HRS (workers compensation); Chapter 392 HRS (temporary disability insurance); and Chapter 393 HRS (pre-paid health care), and shall produce all documents to the State (DLNR, Engineering Division) required to demonstrate compliance with these subsections. Any bidder making a false affirmation or certification under this subsection shall be suspended and may be debarred from further offerings or awards pursuant to §103D-702 HRS.

RECEIPT OF ADDENDA

The bidder also acknowledges receipt of any and all addenda issued by the Engineering Division, by recording the date of receipt of the respective addenda in the space provided below:

<u>Addendum</u>	<u>Date Received</u>	<u>Addendum</u>	<u>Date Received</u>
No. 1	_____	No. 5	_____
No. 2	_____	No. 6	_____
No. 3	_____	No. 7	_____
No. 4	_____	No. 8	_____

It is understood that failure to receive any such addendum shall not relieve the Contractor from any obligation under this Proposal as submitted.

It is also understood and agreed that if this Proposal is accepted and the undersigned should fail or neglect to contract as aforesaid, the Board may determine that the bidder has abandoned the Contract, and thereupon, forfeiture of the security accompanying his proposal shall operate and the same shall become the property of the Board.

JOINT CONTRACTORS OR SUBCONTRACTORS
TO BE ENGAGED ON THIS PROJECT

The Bidder agrees that the following is a complete listing of all joint contractors or subcontractors covered under Chapter 444, Hawaii Revised Statutes (HRS), who will be engaged by the Bidder on this project to perform the required work indicated pursuant to Section 103D-302, HRS. It is the sole responsibility of the contractor to review the requirements of this Project and determine the appropriate licenses that are required to complete the Project. The Bidder certifies that the completed listing of joint contractors or subcontractors fulfills the requirements for the project and the Bidder, together with the listed subcontractors or joint contractors have all the specialty contractor's licenses to complete the work, except as provided for in HRS §103D-302(b). Failure of the Bidder to comply with this requirement may be just cause for rejection of the bid.

“A” General Engineering Contractors and “B” General Building Contractors are reminded that due to the Hawaii Supreme Court’s January 28, 2002 decision in Okada Trucking Co., Ltd. v. Board of Water Supply, et al., 97 Haw. 450 (2002), they are prohibited from undertaking any work, solely or as part of a larger project, which would require the general contractor to act as a specialty contractor in any area in which the general contractor has no license. Although the “A” and “B” contractor may still bid on and act as the “prime” contractor on an “A” or “B” project (See, HRS §444-7 for the definitions of an “A” and “B” project.), respectively, the “A” and “B” contractor may only perform work in the areas in which they have the appropriate contractor’s license (*An “A” or “B” contractor obtains “C” specialty contractor’s licenses either on its own, or automatically under HAR § 16-77-32*). The remaining work must be performed by appropriately licensed entities.

General Engineering “A” Contractors automatically have these “C” specialty contractor’s licenses: C-3, C-9, C-10, C-17, C-24, C-31a, C-32, C-35, C-37a, C-37b, C-38, C-43, C-49, C-56, C-57a, C-57b and C-61.

General Building “B” Contractors automatically have these “C” specialty contractor’s licenses: C-5, C-6, C-10, C-12, C-24, C-25, C-31a, C-32a, C-42a and C-42b.

In completing the Joint Contractors or Subcontractors List, describe the specialty contractor’s nature and scope of work to be performed for this project and provide the complete firm name of the joint contractor or subcontractor in the respective columns. If the Bidder is a general contractor providing the work of a required specialty contractor, whose license is not automatically held pursuant to HAR 16-77-32, fill in the Bidder’s (general contractor’s) name and nature and scope of work to be performed on this project.

List only one joint contractor or subcontractor per required specialty contractor’s classification, unless within the same specialty, the work of each joint contractor or subcontractor can be described so that there is no overlap in work descriptions.

If a contractor’s license is required by law for the performance of the work which is called for in this bid, the bidder and all subcontractors must have the required license before the submission of the bidder’s proposal in the case of a non-federal aid project, and for federal-aid projects, the bidder must have the required license prior to the award of the project and all subcontractors prior to the start of the subcontracted work.

COMPLETE FIRM NAME OF JOINT CONTRACTOR OR SUBCONTRACTOR	NATURE AND SCOPE OF WORK TO BE PERFORMED

Enclosed herewith is a:

1. Surety Bond (*1))
2. Legal Tender (*2))
3. Cashier's Check (*3))
4. Certificate of Deposit (*3)) in the
5. Certified Check (*3)) amount
6. Official Check (*3)) of
7. Share Certificate (*3))
8. Teller's Check (*3))
9. Treasurer's Check (*3))

(Cross Out Those Not Applicable)

_____ Dollars (\$ _____)

as required by law.

Respectfully submitted,

Name of Company, Joint Venture
or Partnership

Contractor's License No.

By _____
Signature (*4)

Title _____

Print Name _____

Date _____

Address _____

Telephone No. _____

E-Mail Address _____

NOTES:

1. Surety bond underwritten by a company licensed to issue bonds in this State;
2. Legal tender; or
3. A certificate of deposit; share certificate; or cashier's, treasurer's, teller's, or official check drawn by, or a certified check accepted by, and payable on demand to the State by a bank, a savings institution, or credit union insured by the Federal Deposit Insurance Corporation or the National Credit Union Administration.
 - A. These instruments may be utilized only to a maximum of \$100,000.
 - B. If the required security or bond amount totals over \$100,000, more than one instrument not exceeding \$100,000 each and issued by different financial institutions shall be accepted.
4. Please attach to this page evidence of the authority of this officer to submit bids on behalf of the Company and also the names and residence addresses of all officers of the Company.
5. Fill in all blank spaces with information asked for or bid may be invalidated. PROPOSAL MUST BE INTACT, MISSING PAGES MAY INVALIDATE YOUR BID.

End of Proposal

SECTION 05500

MISCELLANEOUS METAL FABRICATIONS

PART 1 - GENERAL

1.1 DESCRIPTION OF WORK

- A. Work includes, but is not necessarily limited to providing gates, metal posts, and other items for a complete installation.

1.2 SUBMITTALS

- A. Submit under provisions of Section 01300 – SUBMITTALS

- B. Submit the following:

1. Materials lists of items proposed to be provided under this Section.
2. Manufacturer's specifications and other data needed to prove compliance with the specified requirements.

1.3 QUALITY ASSURANCE

- A. Use adequate numbers of skilled workmen who are thoroughly trained and experienced in the necessary crafts and who are completely familiar with the specified requirements and the methods needed for proper performance of the work of this Section.

1.4 PROJECT CONDITIONS

- A. Examine the areas and conditions under which work of this Section will be performed. Obtain accurate field measurements before fabrication and show measurements on shop drawings. Correct conditions detrimental to timely and proper completion of the work. Do not proceed until unsatisfactory conditions are corrected.

1.5 PRODUCT HANDLING, STORAGE, AND PROTECTION

- A. Use all means necessary to store, handle and protect the materials of this Section, before, during and after installation, from damage affecting either operation or finish.
- B. In the event of damage, immediately make all repairs and replacements necessary at no additional cost to the Owner.

PART 2 - PRODUCTS

2.1 GENERAL MATERIAL SPECIFICATIONS

- A. Asbestos Prohibition: No asbestos containing materials or equipment shall be used under this section. The Contractor shall ensure that all materials and equipment incorporated in the project are asbestos free.
- B. Lead Prohibition: No lead containing materials shall be used under this Section. The Contractor shall ensure that all materials incorporated in the project are lead-free unless specifically approved in writing by the Contracting Officer.
- C. Stainless steel bolts, nuts, anchor bolts, rods: ASTM A307.
- D. Structural Steel: ASTM A36.
- E. Steel Pipe: ASTM A120, standard weight, hot-dipped galvanized, welded and seamless steel pipe.
- F. Stainless Steel Pipe: ASTM A312, schedule 40 standard weight, Type 316, welded and seamless stainless steel pipe.

2.2 GATES, POST, AND RELATED ITEMS

- A. Gates, Posts, and Braces: Use standard weight, Type 316, welded and seamless stainless steel pipes conforming with ASTM A-53-89a, schedule 40 unless otherwise indicated on the drawings. Hydrostatic test are not required.

2.3 GALVANIZED MATERIAL

- A. Galvanize materials in accordance with ASTM A123, or A386, as applicable. Hot-dipped galvanize items after fabrication, except parts to be bolted together which shall be galvanized before final assembly.

2.4 FASTENERS

- A. Stainless steel, unless otherwise indicated.

PART 3 - EXECUTION

3.1 SURFACE CONDITIONS

- A. Prior to work of this Section, carefully inspect the installed work of other trades and verify that such work is complete to the point where the work of this Section may properly com-

mence. Verify that miscellaneous metals may be fabricated and installed in strict accordance with the original design and approved shop drawings.

- B. Make required measurements in the field to ensure proper and adequate fit of miscellaneous metal items.
- C. Report incomplete work and other discrepancies to the Owner. Do not begin work in areas of discrepancy until all such discrepancies have been fully resolved.

3.2 ELECTROLYTIC PROTECTION

- A. Where materials dissimilar in galvanic range are in contact, or aluminum is in contact with concrete, paint contact surfaces with primer and body coats of bituminous paint, such as Koppers Bitumastic 505. Paint shall be compatible with other coatings and materials in direct contact. Allow paint to dry thoroughly before install metalwork.

3.3 FABRICATION

- A. Field verify all dimensions prior to fabrication.
- B. Make all work square, plumb, straight, and true. Corners shall be mitered and all welds ground smooth prior to galvanizing and priming.
- C. Grind all welds smooth. For materials that are galvanized, paint with two coats of "Galvalloy," "Galvicon," or equivalent.
- D. Attach hardware with rivets or by other means which will provide security against removal and breakage
- E. Assemble handrails by welding with special malleable or pressed steel fittings for rigid connections. Make all joints and intersections of metals tightly fitting and securely fastened.
- F. Insofar as possible, prefabricate all items in the shop, complete and ready for erection.
- G. Install gates plumb, level, and secure for full opening without interference. Lubricate and adjust the hardware for smooth operation.

3.4 INSTALLATION

- A. Install metalwork in strict accordance with the original design and approved shop drawings. Install commercially manufactured products in accordance with the manufacturer's recommendations. Installed work shall be fastened securely and neatly.

END OF SECTION

SECTION 05522

STAINLESS STEEL PIPE RAILS

PART 1 - GENERAL

1.1 GENERAL REQUIREMENTS

This section covers the requirements for furnishing and installing stainless steel handrails and railings.

- A. Take and be responsible for all required measurements in the field to verify and supplement dimensions shown on the drawings.

1.2 SUBMITTALS

- A. Product data: For each component, submit product data indicating they meet ASTM standards referred under "materials" below PART 2.1 – MATERIALS
- B. Shop Drawings: Shop drawings shall be submitted to the Engineer for review and approval. Show fabrication and installation of railings. Include plans, elevations, sections, component details, and attachments to other Work.
- C. Calculations: Structural analysis data signed and sealed by a qualified Professional Engineer licensed in the state of Hawaii, indicating that the railing installation complies with design loads.
- D. Sample: Assembled sample of railing system, made from full-size components, including top rail, post, and midrails. Show method of finishing members at intersections. Sample need not be full height.

1.3 SYSTEM PERFORMANCE

Structural Performance of Handrails and Railings: Provide handrails and railings capable of withstanding structural loads required by the current 2006 IBC, but not less than the following structural loads without exceeding allowable design working stress of materials for handrails, railings, anchors, and connections based on testing performed in accordance with ASTM E 894 and ASTM E 935:

- A. Top Rail of Guards: Capable of withstanding the following loads applied as indicated:
 - 1. Concentrated load of 200 pounds applied at any point and in any direction.
 - 2. Uniform load of 50 pounds per linear foot applied horizontally and concurrently with uniform load of 100 pounds per linear foot applied

vertically downward.

3. Concentrated and uniform loads above need not be assumed to act concurrently.
- B. Handrails Not Serving As Top Rails: Capable of withstanding the following loads applied as indicated:
1. Concentrated load of 200 pounds applied at any point and in any direction.
 2. Uniform load of 50 pounds per linear foot applied in any direction.
 3. Concentrated and uniform loads above need not be assumed to act concurrently.
- C. Infill Area of Guards: Capable of withstanding a horizontal concentrated load of 200 pounds applied to 1 square foot at any point in system, including panels, intermediate rails, balusters, or other elements composing infill area. Load above need not be assumed to act concurrently with loads on top rails in determining stress on guard.
- D. The structural strength of all metal railings and guardrails and all fasteners and mounting devices shall meet or exceed the accessibility requirements of ADAAG Section 609.8.

PART 2 – PRODUCTS

2.1 MATERIALS

- A. All stainless steel pipe railing shall be Type 316 Schedule 40 pipe of the sizes and dimensions shown on the plans or as specified by the Engineer. Stainless steel round pipe railing shall meet the requirements of ASTM A312/A312 M, Type 316.
- B. Stainless steel bars and plates shall meet the requirements of ASTM A666, Type 316.
- C. Set screws, anchor bolts, brackets, flanges and other fasteners to be fabricated from Type 316 stainless steel
- D. Epoxy grout for post holes shall be Sikadur[®] 32, Hi-Mod Gel, conforming to ASTM C-881, Type I and II, Grade 3, Class B and C epoxy resin adhesive or approved equal.

PART 3 - EXECUTION

3.1 FABRICATION AND INSTALLATION

- A. Drill or preform holes for post with blockouts or sleeves to the required depth, as shown on the plans.
- B. The line and grade of the railing shall be true to that shown on the Plans and shall not

follow any unevenness to the surface on which the railing is placed. All posts shall be constructed vertically. All joints shall be welded and ground smooth. All shop and field welding shall conform to AWS "Structural Welding Code" AWS D1.1-72.

- C. Storage of materials - Railing materials shall be stored off the ground on platforms, pallets, or other supports. These materials shall be kept free from grease and dirt and shall be protected from moisture until they have been properly installed.
- D. Condition of materials: Railing materials, before being installed or worked, must be straight. If straightening is necessary, it shall be done by methods that will not injure the appearance or body of the metal. Sharp kinks and bends shall be cause for rejection of the material.
- E. Layout: Spacing of posts shall be as shown on the Plans. The Contractor shall set pipe posts in holes as shown on the Plans. The Contractor shall submit five sets of shop drawings for approval by the Engineer before fabricating the railings.
- F. Fabrication and Erection:
 - 1. Assemble railings in the shop to greatest extent possible to minimize field splicing and assembly.
 - 2. Joining of the material shall be by methods shown on the detail drawings. Railing shall be carefully adjusted prior to being fixed in place to insure proper matching at abutting joints and correct alignment, curvature and camber throughout their length. Railing on curves or return bends shall be fabricated to a smooth curve throughout the length of the curve as specified above. All exposed ends of rail shall be covered with an Engineer approved seal.
 - 3. Bending shall be by bending machine or tools to maintain the same interior cross-sectional area. Vise or pipe tee will not be allowed.
 - 4. Cutting: Material of 0.5-inch thickness or less may be sheared, sawed or milled. Cut edges shall be true, smooth and free from burrs or ragged breaks.
 - 5. Post anchoring shall be in accordance with the Plans. Epoxy grout shall be installed in accordance with the manufacturer's specifications. The surface must be clean and sound, free of standing water, dust, grease, curing compounds, etc.
 - 6. At exposed connections, finish exposed surfaces smooth and blended so no roughness shows after finishing and welded surface matches contours of adjoining surfaces.
- G. FINISHING
 - 1. Grind and polish surfaces to produce uniform, directionally textured polished No.4 finish free of cross scratches. Run grain with long dimension of each piece.

2. When polishing is completed, passivate and rinse surfaces. Remove embedded foreign matter and leave surfaces chemically clean.

3.2 CLEAN-UP

Upon completion of work under this section, remove and dispose of all surplus materials, rubbish, and debris resulting from operations and leave entire site in neat and clean condition acceptable to the Engineer.

END OF SECTION

Pre-Offer Meeting Minutes for Job No. F55C642D, Waianapanapa State Park Walkway Improvements, Hana, Maui, Hawaii

Date: January 19, 2016 commenced at 9:00 a.m.

Location: Engineering Division Conference Room, located at 1151 Punchbowl Street, Room 221, Honolulu; and at the Maui Engineering Division Office (via telecom), located at 130 Mahalani Street, Wailuku, Maui

Meeting was opened by the Project Engineer, Valerie Suzuki, who stated the following:

Brief Description of Project and Scope:

The work shall generally consist of reconstructing the park's walkways, stairways and railings; and adding new benches and a new boardwalk.

Offer due date is on February 4, 2016 at 2:00 p.m. Bids shall be uploaded to the HiePRO website.

Last day to turn in RFIs is January 28, 2016.

The following questions and responses are as follows:

1. If during the sidewalk/boardwalk/stair installation and there is a tree with a lot of roots cut, who makes the call to save or remove the tree?

See revised notes on Sheet C-3, C-4, C-5. See Addendum No. 1.

2. Can the contractor stay in the cabin?

See revised specification Section 01019 – General Specifications for cabin use in Addendum No. 1.

SIGN-IN SHEET
PRE-BID CONFERENCE

Job Title: Waianapanapa State Park Walkway Improvements, Hana, Maui, Hawaii
 Job Number: F55C642D, Date: January 19, 2016 Time: 9:00 a.m.

	NAME	AGENCY	PHONE NO.	FAX NO.	EMAIL ADDRESS
1	Curtis Powers	DLNR-Engineering	808-243-5187	808-243-5187	curtis.d.powers@hawaii.gov
2	MIKE SILVA	FUKUMOTO ENGINEERING	242-8611		mike@femai.com
3	MANDY SAITO	FUKUMOTO ENGINEERING	" "		mandy@femai.com
4	BRIAN OKUDA	ARISHI BROTHERS	808 877-504		brian brian@arishibrothers.com
5	CURTIS POWERS	DLNR-ENG.	243-5187		
6	Satish K. Ghoshkar	Ghoshkar Associates	243-2248		Satish@hawaiiassoc.com
7	Robyn Skon	Zoe Builders	249 2002		Robyn@zoebuilders.com
8					
9					
10					
11					
12					
13					
14					

SIGN-IN SHEET
PRE-BID CONFERENCE

Job Title: Waianapanapa State Park Walkway Improvements, Hana, Maui, Hawaii
 Job Number: F55C642D, Date: January 19, 2016 Time: 9:00 a.m.

	NAME	AGENCY	PHONE NO.	FAX NO.	EMAIL ADDRESS
1	Valerie Suzuki	DLNR-Engineering	587-0275	587-0283	valerie.s.suzuki@hawaii.gov
2	Melissa Agbayani	DLNR-Engineering	587-0233	587-0283	Melissa.M.Agbayani@hawaii.gov
3					
4					
5					
6					
7					
8					
9					
10					
11					
12					
13					
14					

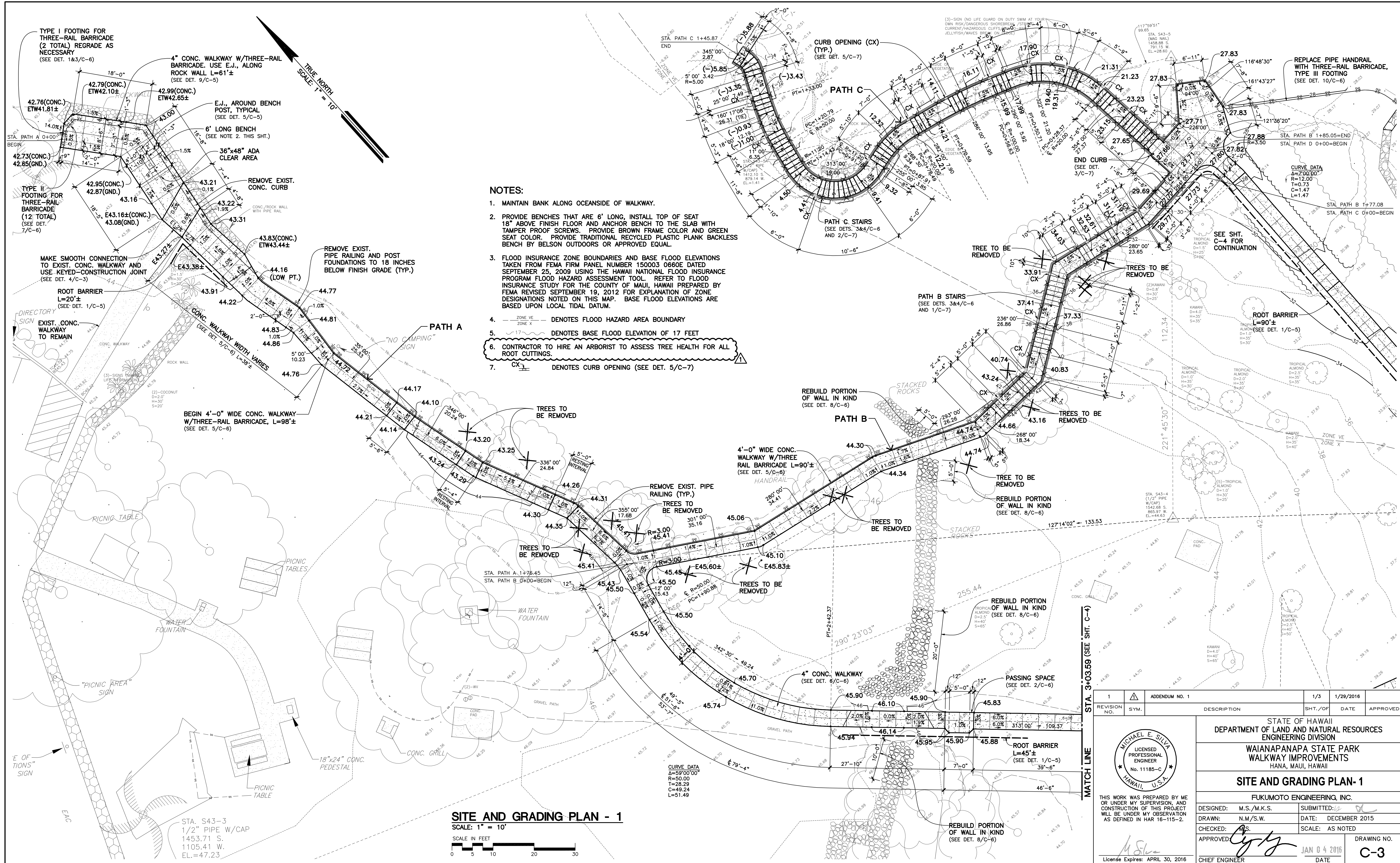

SITE AND GRADING PLAN - 1

SCALE: 1" = 10'
SCALE IN FEET

REVISION NO.	SYM.	DESCRIPTION	SHT./OF	DATE	APPROVED
1		ADDENDUM NO. 1	1/3	1/29/2016	

		STATE OF HAWAII DEPARTMENT OF LAND AND NATURAL RESOURCES ENGINEERING DIVISION WAIANAPANAPA STATE PARK WALKWAY IMPROVEMENTS HANA, MAUI, HAWAII SITE AND GRADING PLAN- 1 FUKUMOTO ENGINEERING, INC. DESIGNED: M.S./M.K.S. SUBMITTED: [Signature] DRAWN: N.M/S.W. DATE: DECEMBER 2015 CHECKED: [Signature] SCALE: AS NOTED APPROVED: [Signature] CHIEF ENGINEER License Expires: APRIL 30, 2016	
THIS WORK WAS PREPARED BY ME OR UNDER MY SUPERVISION, AND CONSTRUCTION OF THIS PROJECT WILL BE UNDER MY OBSERVATION AS DEFINED IN HAR 16-115-2.		DRAWING NO. C-3 DATE JAN 04 2016 SHEET NO. 4 OF 11 SHEETS	

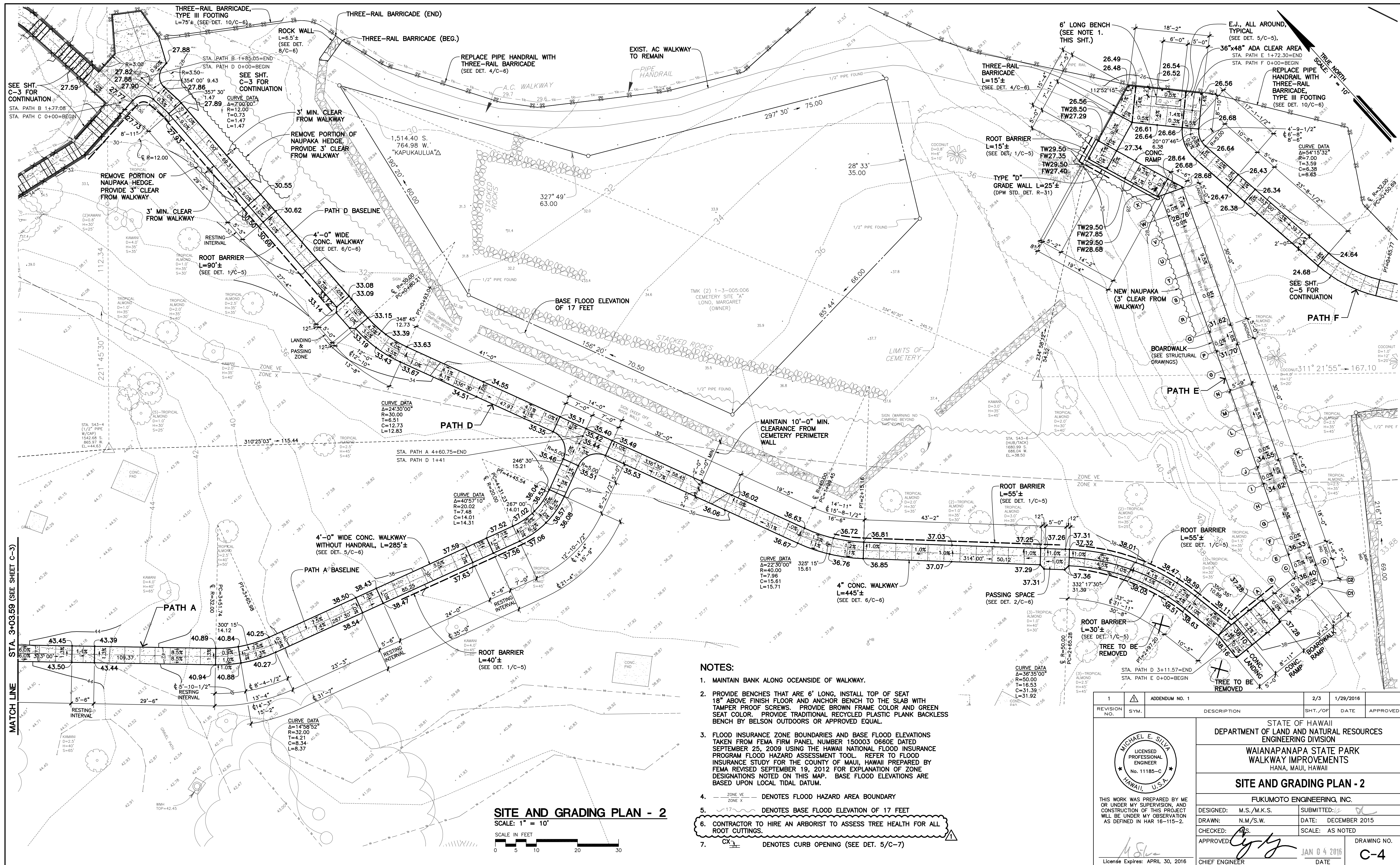

SITE AND GRADING PLAN - 2

SCALE: 1" = 10'



NOTES:

1. MAINTAIN BANK ALONG OCEANSIDE OF WALKWAY.
2. PROVIDE BENCHES THAT ARE 6' LONG, INSTALL TOP OF SEAT 18" ABOVE FINISH FLOOR AND ANCHOR BENCH TO THE SLAB WITH TAMPER PROOF SCREWS. PROVIDE BROWN FRAME COLOR AND GREEN SEAT COLOR. PROVIDE TRADITIONAL RECYCLED PLASTIC PLANK BACKLESS BENCH BY BELSON OUTDOORS OR APPROVED EQUAL.
3. FLOOD INSURANCE ZONE BOUNDARIES AND BASE FLOOD ELEVATIONS TAKEN FROM FEMA FIRM PANEL NUMBER 150003 06606 DATED SEPTEMBER 25, 2009 USING THE HAWAII NATIONAL FLOOD INSURANCE PROGRAM FLOOD HAZARD ASSESSMENT TOOL. REFER TO FLOOD INSURANCE STUDY FOR THE COUNTY OF MAUI, HAWAII PREPARED BY FEMA REVISED SEPTEMBER 19, 2012 FOR EXPLANATION OF ZONE DESIGNATIONS NOTED ON THIS MAP. BASE FLOOD ELEVATIONS ARE BASED UPON LOCAL TIDAL DATUM.
4. --- ZONE VE --- DENOTES FLOOD HAZARD AREA BOUNDARY
5. --- 17 --- DENOTES BASE FLOOD ELEVATION OF 17 FEET
6. CONTRACTOR TO HIRE AN ARBORIST TO ASSESS TREE HEALTH FOR ALL ROOT CUTTINGS.
7. DENOTES CURB OPENING (SEE DET. 5/C-7)

1	ADDENDUM NO. 1	2/3	1/29/2016		
REVISION NO.	SYM.	DESCRIPTION	SHT./OFF	DATE	APPROVED
STATE OF HAWAII DEPARTMENT OF LAND AND NATURAL RESOURCES ENGINEERING DIVISION WAIANAPANAPA STATE PARK WALKWAY IMPROVEMENTS HANA, MAUI, HAWAII SITE AND GRADING PLAN - 2					
FUKUMOTO ENGINEERING, INC. DESIGNED: M.S./M.K.S. SUBMITTED:					
DRAWN: N.M./S.W. DATE: DECEMBER 2015					
CHECKED: SCALE: AS NOTED					
APPROVED: DATE: JAN 04 2016					
CHIEF ENGINEER DRAWING NO. C-4					

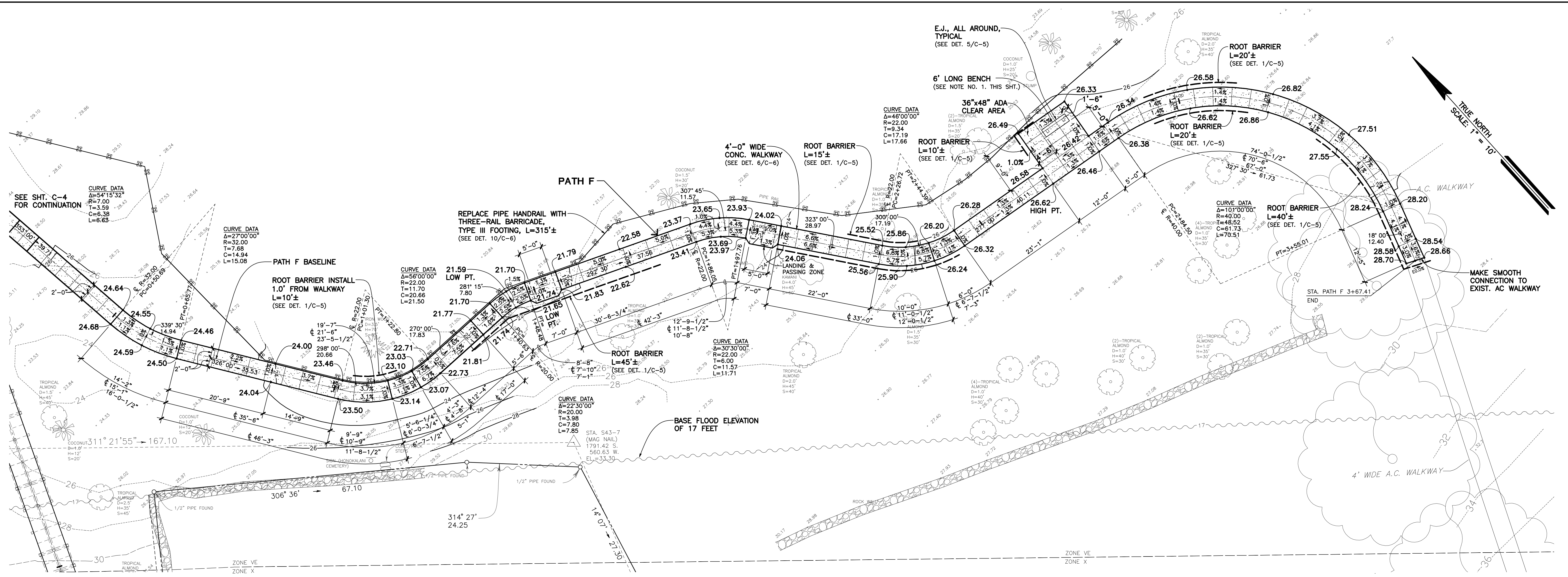

SITE AND GRADING PLAN - 3

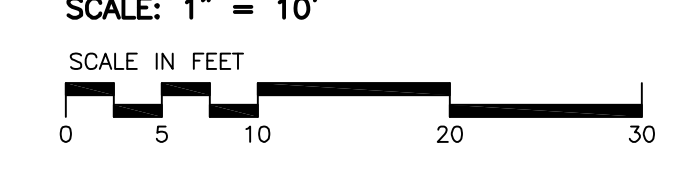

NOTES:

- MAINTAIN BANK ALONG OCEANSIDE OF WALKWAY.
- PROVIDE BENCHES THAT ARE 6' LONG, INSTALL TOP OF SEAT 18" ABOVE FINISH FLOOR AND ANCHOR BENCH TO THE SLAB WITH TAMPER PROOF SCREWS. PROVIDE BROWN FRAME COLOR AND GREEN SEAT COLOR. PROVIDE TRADITIONAL RECYCLED PLANK BACKLESS BENCH BY BELSON OUTDOORS OR APPROVED EQUAL.
- FLOOD INSURANCE ZONE BOUNDARIES AND BASE FLOOD ELEVATIONS TAKEN FROM FEMA FIRM PANEL NUMBER 150003 0660 DATED SEPTEMBER 25, 2009 USING THE HAWAII NATIONAL FLOOD INSURANCE PROGRAM FLOOD HAZARD ASSESSMENT TOOL. REFER TO FLOOD INSURANCE STUDY FOR THE COUNTY OF MAUI, HAWAII PREPARED BY FEMA REVISED SEPTEMBER 19, 2012 FOR EXPLANATION OF ZONE DESIGNATIONS NOTED ON THIS MAP. BASE FLOOD ELEVATIONS ARE BASED UPON LOCAL TIDAL DATUM.
- ZONE VE --- DENOTES FLOOD HAZARD AREA BOUNDARY
- ~ 17' ~ DENOTES BASE FLOOD ELEVATION OF 17 FEET
- CONTRACTOR TO HIRE AN ARBORIST TO ASSESS TREE HEALTH FOR ALL ROOT CUTTINGS.
- CX DENOTES CURB OPENING (SEE DET. 5/C-7)

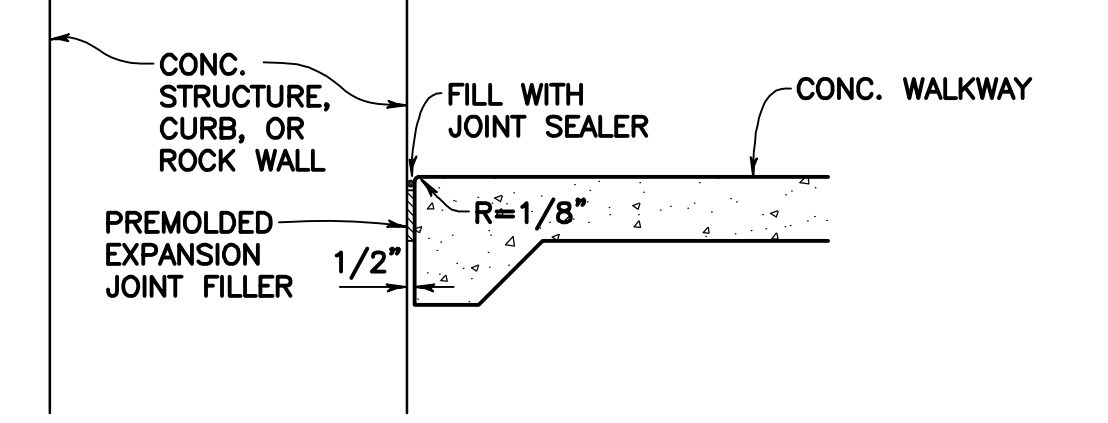

5 EXPANSION JOINT (E.J.)
SCALE: 1" = 1'-0"

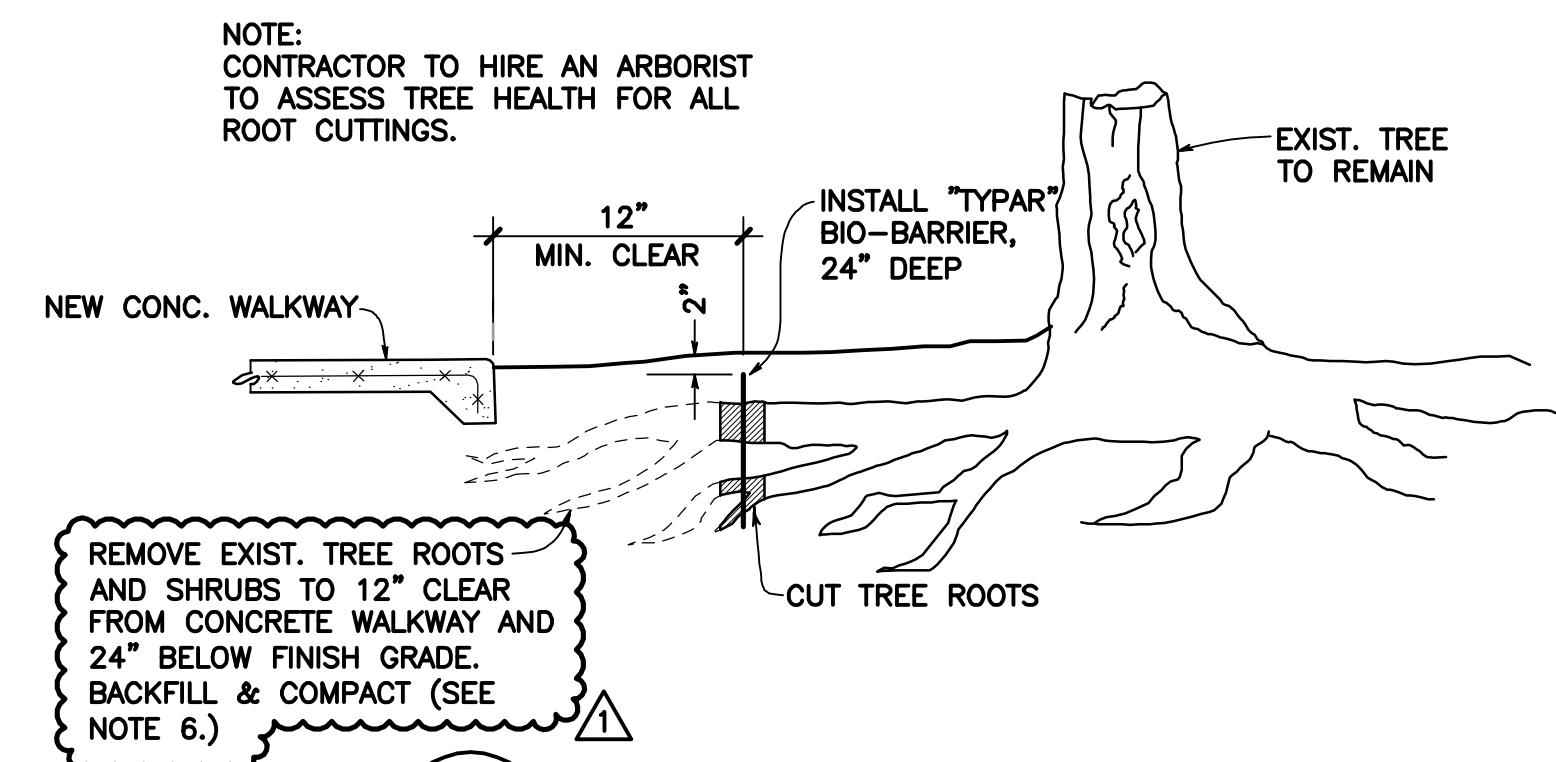

1 ROOT BARRIER DETAIL
NOT TO SCALE

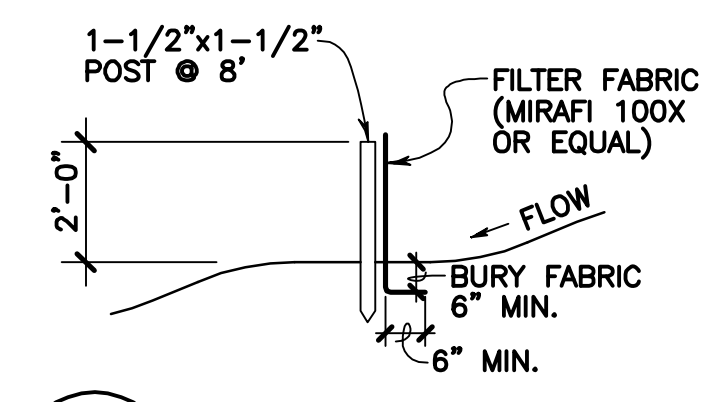

2 SILT FENCE SECTION
NOT TO SCALE

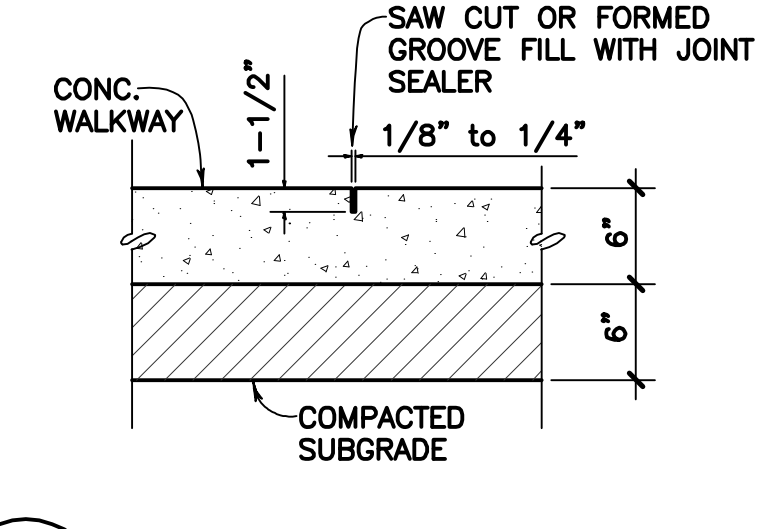

3 CONTRACTION JOINT (C.J.)
SCALE: 1" = 1'-0"

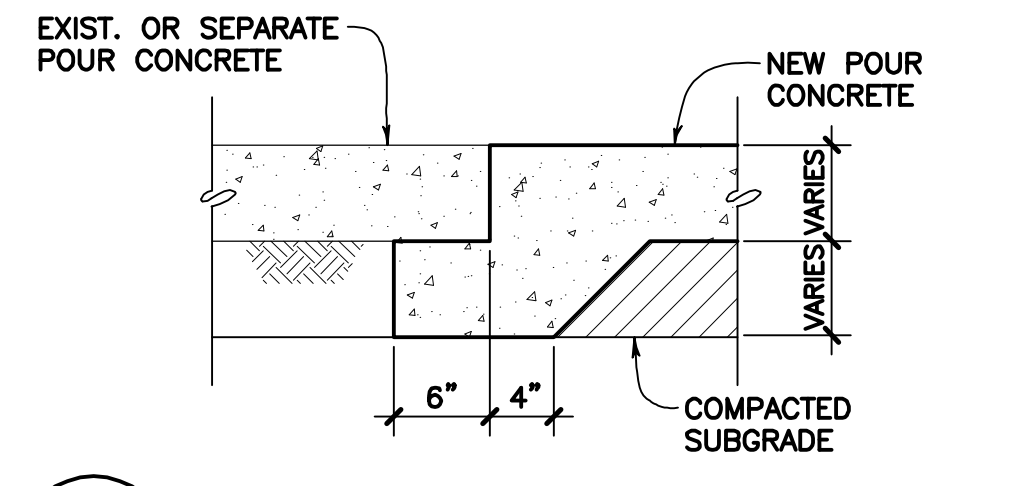

4 KEYED-CONSTRUCTION JOINT
SCALE: 1" = 1'-0"

NOTE: CONTRACTOR TO HIRE AN ARBORIST TO ASSESS TREE HEALTH FOR ALL ROOT CUTTINGS.

REMOVE EXIST. TREE ROOTS AND SHRUBS TO 12" CLEAR FROM CONCRETE WALKWAY AND 24" BELOW FINISH GRADE. BACKFILL & COMPACT (SEE NOTE 6.)

1	ADDENDUM NO. 1	3/3	1/29/2016		
REVISION NO.	SYM.	DESCRIPTION	SHT./OF	DATE	APPROVED
STATE OF HAWAII DEPARTMENT OF LAND AND NATURAL RESOURCES ENGINEERING DIVISION WAIANAPANAPA STATE PARK WALKWAY IMPROVEMENTS HANA, MAUI, HAWAII					
SITE AND GRADING PLAN - 3 AND DETAILS					
FUKUMOTO ENGINEERING, INC.					
DESIGNED:	M.S./M.K.S.	SUBMITTED:			
DRAWN:	N.M./S.W.	DATE:	DECEMBER 2015		
CHECKED:	MS.	SCALE:	AS NOTED		
APPROVED:	<i>MS.</i>				
CHIEF ENGINEER		JAN 04 2016			
License Expires: APRIL 30, 2016		DATE			